

ANTES DE COMENZAR, RECOPILE TODO EL MATERIAL DE APOYO PARA EL MONTAJE: Instrucciones de montaje / ilustraciones paso a paso / planos y plantillas impresos a escala.

PREPARACIÓN DEL MATERIAL: Para poder identificar correctamente las piezas precortadas, antes de extraerlas de las planchas de madera, marque en ellas la misma numeración que aparece en la hoja "IP" (identificación de piezas), incluida en las instrucciones. El grueso de los tableros puede variar medio milímetro de más o de menos.

INICIO DEL MONTAJE: Con la ayuda de un cúter y procurando no colocar los dedos en la línea de corte, desprenda las piezas de las planchas eliminando los pequeños nervios que las sujetan. Seguidamente lije con suavidad las piezas con papel de lija de grano fino, para eliminar el repelo de las mismas. El orden numérico del paso a paso indica el orden de elaboración y colocación de las piezas. Es importante comprobar el ajuste de las piezas antes de pegarlas definitivamente.

LISTONES Y VARILLAS: Los modelos incorporan varios tipos de listones y varillas para elaborar las diferentes piezas. La lista de piezas proporciona información sobre el tipo de material y medidas. En algunos casos es conveniente ajustar las medidas sobre el propio modelo, conforme avanzamos en el montaje. De esta manera se consigue un mejor ajuste.

PEGAMENTOS RECOMENDADOS: Cola blanca o de carpintero. Para las uniones de piezas de madera y de todas aquellas piezas que no ofrezcan resistencia.

Pegamento rápido. Para piezas que sean difíciles de sostener y que necesiten un secado casi instantáneo.

Cola de contacto o de zapatero. Para todas aquellas piezas que se forren con chapas finas de madera o metal. En todos los casos, lea siempre las instrucciones de uso del fabricante.

SERVICIO DE ATENCIÓN AL CLIENTE: Para cualquier duda o información sobre el montaje de nuestros productos, puede contactar con nuestro Servicio Técnico en la dirección:

www.occre.com. Le atenderemos con mucho gusto.

BEFORE STARTING, MAKE SURE YOU HAVE ALL THE SUPPORT MATERIAL FOR ASSEMBLING THE MODEL:

Assembly Instructions / Step by step pictures / Plans and templates printed to scale.

PREPARING THE MATERIAL: In order to correctly identify the precut parts, before removing them from the wooden sheets, mark on them the same numbers that appear on the "IP" (Part Identification) Sheet included with the instructions. The thickness of the boards can vary by half a millimeter more or less.

STARTING THE ASSEMBLY: Using a cutter, and making sure you do not put your fingers along the cutting line, remove the parts from the wooden sheets, eliminating the small sprues that hold them in place. In continuation smoothly sand down the parts, using fine grain sandpaper, to eliminate the pickup of the parts. The numerical order indicates the order in which the different parts must be made up and fitted.

STRIPS AND RODS: These models incorporate a variety of different types of strips and rods with which to make up the different parts of the kit. The list of parts proportions information on the type of material and measurements. In some cases it is advisable to adjust the measurements on the basis of the model itself, as assembly progresses. In this way you will achieve a better fit.

RECOMMENDED GLUES: White, or carpenter's glue: For joining pieces of wood together. Mainly used for gluing together the skeleton. Quick-drying glue. For parts that are difficult to hold in their final position and which need to set instantly. Recommended for fitting small parts. Contact or cobbler's glue. For gluing into place the parts that are covered with fine wood veneer to set instantly. In all cases, always follow the manufacturer's recommendations.

CUSTOMER ATTENTION SERVICE: In the case of whatsoever doubt or further information that you may require regarding the assembly of our products, please contact our Technical Service online at the address: www.occre.com. We will be delighted to attend to you.

AVANT DE COMMENCER, VÉRIFIEZ TOUT LE MATÉRIEL DE SOUTIEN POUR LE MONTAGE: Instructions de montage / Images étape par étape / Plans et modèles imprimés à l'échelle.

PRÉPARATION DU MATÉRIEL: Pour pouvoir identifier correctement les pièces prédécoupées, avant de les extraire des planches de bois, inscrivez sur elles la même numérotation qui apparaît sur la page « IP » (identification des pièces) comprise dans les instructions. L'épaisseur des planches peut varier d'un demi-millimètre plus ou moins.

DÉBUT DU MONTAGE: À l'aide d'un cutter, et en essayant de ne pas poser les doigts sur la ligne de découpe, séparez les pièces des planches en éliminant les petits nerfs qui les retiennent. Puis poncez doucement les pièces à l'aide d'un papier de verre à grain fin, pour éliminer le contrefil. L'ordre numérique des étapes photographiques et des plans indique l'ordre d'élaboration et d'installation des pièces.

LISTEAUX ET BAGUETTES: Les modèles intègrent plusieurs types de listeaux et de baguettes destinés à confectionner les différentes pièces. La liste des pièces indique le type de matériau et les dimensions des pièces. Il est parfois recommandé d'ajuster les mesures sur le modèle lui-même, au fur et à mesure que nous avançons dans le montage. De cette manière, on obtient un meilleur réglage.

COLLES RECOMMANDÉES: Colle blanche ou de menuisier: Pour les unions de pièces en bois et de toutes les pièces qui n'offrent pas de résistance. Colle à séchage rapide: Pour les pièces qui sont difficiles à maintenir dans leur position et qui requièrent un séchage pratiquement instantané. Colle de contact ou de cordonnier: Pour toutes les pièces qui sont recouvertes de fines plaques de bois ou de métal. Dans tous les cas, lisez toujours les instructions d'utilisation du fabricant.

SERVICE CLIENT: Pour toute question ou information concernant le montage de nos produits, vous pouvez contacter notre Service Technique à l'adresse suivante: www.occre.com.

Nous répondrons avec plaisir à vos questions.

PRIMA D'INIZIARE, RIUNIRE TUTTO IL MATERIALE D'APPOGGIO PER IL MONTAGGIO: Istruzioni di montaggio, immagini passo per passo, planimetrie e modelli stampati in scala.

PREPARAZIONE DEL MATERIALE: Per poter identificare in maniera corretta i pezzi che sono stati ritagliati, prima di estrarli dai blister di legno occorre segnarli con la stessa numerazione che è indicata nella pagina "IP" (Identificazione pezzi) che si trova nelle istruzioni. Lo spessore delle tavole può variare di mezzo millimetro in più o in meno.

INIZIO DEL MONTAGGIO: Con l'aiuto di un cutter, ed evitando di collocare le dita lungo la linea di taglio, separare i pezzi dai blister eliminando i piccoli nervi che li mantengono attaccati. In seguito, scartare con delicatezza i pezzi, utilizzando una carta vetrata a grana fine, onde eliminare le sbavature degli stessi. L'ordine numerico del passo per passo indica l'ordine d'elaborazione e di collocazione dei pezzi. È importante verificare che questi combacino bene, prima d'incollarli definitivamente.

ASTE E BACCHETTE: I modelli sono dotati di vari tipi di aste e bacchette per formare i diversi pezzi. L'elenco dei pezzi offre informazioni sul tipo di materiale e sulle misure. In alcuni casi è conveniente modificarne le misure quando sono sul modello, man mano che si avanza nel montaggio. In questo modo si potrà ottenere che combacino meglio.

COLLE RACCOMANDATE: Colla bianca o da falegname: Per unire tra loro i pezzi in legno e tutti quei pezzi che non presentino resistenza. Colla rapida: Per i pezzi difficili da sostenere e per i quali sia necessaria un'asciugatura quasi istantanea. Colla a contatto o da calzolaio: Per tutti quei pezzi che vengono rivestiti con fine lastre di legno o di metallo. In ogni caso, leggere sempre le istruzioni d'uso del produttore.

SERVIZIO ASSISTENZA CLIENTE: Per qualsiasi dubbio o informazione sul montaggio dei nostri prodotti, contattare il nostro Servizio Tecnico al seguente indirizzo: www.occre.com.

Seremo lieti di potervi aiutare.

BEVOR SIE MIT DEM ZUSAMMENBAU BEGINNEN, LEGEN SIE SICH BITTE ALLE HILFSMATERIALIEN FÜR DIE MONTAGE BEREIT:

Bastelanleitung / Maßstabsgerechte Skizzen und Schablonen / Skizzen und Vorlagen.

VORBEREITUNG DER MATERIALIEN: Damit die einzelnen Bauteile korrekt zugeordnet werden können, empfehlen wir, auf den Holzplättchenvor dem Herausnehmen mit einem Bleistift die Nummer auf dem Blatt IP (Identifikation Teile) zu markieren. Die Dicke der Bretter kann um mehr oder weniger einen halben Millimeter variieren.

BEGINN DES ZUSAMMENBAUS: Die Teile mit einem Schneidewerkzeug (Cutter) herauslösen und die kleinen Befestigungsenden entfernen. Dabei darauf achten, die Finger nicht zu verletzen. Danach die Teile vorsichtig mit feinem Schmirgelpapier säubern, um ausgefranste Ränder zu entfernen. Die Nummernfolge der Schritte auf Fotos und Skizzen gibt an, in welcher Reihenfolge die Teile zusammengebaut werden.

LEISTEN UND STÄBE: Die Modelle enthalten mehrere Arten von Leisten und Stäben, aus denen die einzelnen Teile des Bausatzes geformt werden. In einigen Fällen kann es angebracht sein, die Maße im Zuge des Zusammenbaus entsprechend dem Modell anzupassen. Auf diese Weise wird eine bessere Passform errichtet.

EMPFOHLENE KLEBSTOFFE: Weißleim (Tischlerleim): Zum Kleben von Strukturteilen und allen nachgiebigen Teilen. Sekundenkleber: Für schwer zu haltende Teile, die schnell verklebt werden müssen. Kontaktkleber (Schusterleim): Für alle Teile, die mit dünnen Holz- oder Metallstücken zum Beplanken oder Verkleiden beklebt werden. Bitte beachten Sie stets die Hinweise des Herstellers.

UNSER KUNDENDIENST: Bei Fragen zum Aufbau unserer Modelle steht Ihnen unser Kundendienst zur Verfügung. Sie erreichen uns online unter: www.occre.com.

Wir stehen Ihnen gern mit Rat und Tipps zur Verfügung.

A-B-C. Utilice una superficie plana y estable para pegar las piezas A1 y A2. Refuerce su unión con las piezas A3. Siguiendo el orden alfanumérico inserte y pegue las piezas indicadas en las imágenes. Antes de encolar las cuadernas, verifique que encajan correctamente en su posición haciendo "tope" en los encajes correspondientes de la falsa quilla. Es importante que las cuadernas queden completamente perpendiculares a la falsa quilla para que posteriormente encajen bien las cubiertas. Para estas operaciones utilice como adhesivo cola blanca, (Ref.19200). Corte a medida las piezas C26. Sitúelas como le muestra la imagen y marque la parte que sobresale de la base. Realice un rebaje para que cuando las coloque en la estructura, queden a la medida que se le indica.

D. Corte a medida y pegue los refuerzos D1 en la parte delantera de la falsa quilla contra las cuadernas. Recorte la figura de la plantilla PL-01 y péguela delante. Utilice un cúter para desbastar los refuerzos. Después, rebájelos con una lima. Vaya pegando las demás piezas que se le indican en las imágenes. Presente la figura de la plantilla PL-01 sobre la cubierta D5 y trace las líneas que se le muestran en la imagen. Halle el centro de la cubierta y marce líneas transversales a la cubierta cada 60mm. Ajuste y pegue las cubiertas D5 a D8 y siga trazando las líneas para completar el total del casco.

E. Corte las tiras de forro E1 a medida y destaque sus cantos con un lápiz. Comience a forrar la cubierta ajustando la primera chapa a la línea que le indica la imagen. Pegue las tiras muy juntas para que no se noten las uniones. Utilice como adhesivo cola de contacto, (cola de zapatero). Frote las tiras contra la cubierta para que se adhieran con firmeza. Forre toda la cubierta y vaya abriendo los orificios de la cubierta para no perderlos de vista. Después, corte los sobrantes de las tiras con un cúter. Lije la cubierta hasta dejar su superficie fina y homogénea. Después, elimine el polvo resultante del lijado y aplique barniz satinado, (Ref.19209).

F. Pegue entre sí las piezas F1 y F2 alineándolas por sus partes rectas. Pegue los conjuntos obtenidos enrasados con la última cuaderna del esqueleto. Recorte las dos plantillas de papel y péguelas como le indica la imagen. Coloque el casco boca abajo y comience a lijar empezando desde popa y avanzando hacia proa. Debe desbastar los refuerzos y las aristas de las cuadernas, pero sin deformar su forma original. Debe lijar hasta llegar a las curvas de las plantillas. El lijado del casco ha de quedar simétrico, es decir, que el lateral derecho ha de quedar igual que el izquierdo. Para la zona media del casco, utilice un taco lijador con mayor superficie. El lijado debe ser progresivo y suave. En la zona de proa, comience lijando desde proa y avanzando hacia popa. Compruebe con un listón, que el lijado es correcto. Para ello, debe deslizar el listón, sobre las cuadernas, para ver como se ajusta a su forma.

G-H-i. Comience el forrado del casco con los listones G1. Si los listones estuvieran muy secos y se le rompen al curvarlos, sumérjalos en agua unos veinte minutos. Con esta operación, recuperarán flexibilidad. Después, séquelos con un paño. Debe pegar el primer listón ajustado a la cubierta de proa y enrasado por su parte superior. Utilice cola blanca, (Ref.19200) o pegamento rápido, (Ref.19201). Después, deberá clavarlo con puntas A. Pegue otro listón G1 para dar continuidad al primero hasta la parte trasera del casco. Los demás listones del forro debe pegarlos a las cuadernas y entre sí, con cola blanca y fijarlos con puntas. Continúe pegando listones desde proa hasta popa para forrar el casco entero. Deberá cortar a medida y ajustar las piezas para que encajen en los huecos. Presente las piezas i1, i2, i3, i4, i5 e i6 en el casco para apreciar cómo debe ajustar el forro teniendo en cuenta que también habrá un segundo forro de 0,6mm de grueso. Si en algún punto le ha quedado algún listón suelto, puede aplicar pegamento de secado rápido. Si le ha quedado algún listón más hundido, pegue otro encima y después, líjelo. Lime las cabezas de las puntas con una lima plana hasta que queden enrasadas con el forro. Diluya un poco de cola blanca con agua para que pueda aplicarla ligeramente y se filtre entre las juntas de los listones. Reserve el casco hasta que la cola se seque. Con esta operación se unificará el forro del casco ganando así consistencia. Después, lije todo el casco. Debe quedar suave y sin desniveles. Aplique cola de contacto, (cola de zapatero), a la zona del casco que le indican las imágenes. Encole y pegue las tiras de forro i7. Debe combinar tiras i7 para completar la longitud total del casco. Corte a medida las tiras de forro dependiendo de la necesidad. Frote las tiras de forro para que se adhieran con firmeza. Pegue las piezas i1 a i6 de forma definitiva y ajuste con una lima al forro.

J-K-L. Coloque el casco boca abajo y aplique masilla tapa-grietas, (Ref. 19143), para rellenar aquellos espacios que puedan haber quedado entre listones. Aplíquela a todo lo largo del casco para unificar sus superficies y tapar posibles fallos. Cuando se haya secado, lije el casco para dejarlo bien fino. Es aconsejable enmascarar la cubierta con papel y cinta de carroceros para protegerla del polvo del pulido. Aplique imprimación, (Ref.19142), a toda la superficie del casco. Cuando se haya secado, pula el casco con esponja-lijadora fina y repita el proceso de enmasillado e imprimado hasta que quede bien fino y uniforme. Para elaborar los timones deberá utilizar piezas de latón fotograbado. Extráigalas de la plancha con un cúter y elimine los restos de los nervios de unión con un limatón. Imprima los timones una vez construidos. Elabore los codastes del casco siguiendo las indicaciones del paso a paso.

M-N. Recorte las plantillas PL-02 y PL-03 y pegue las porciones obtenidas como le indican las imágenes. Presente las plantillas en el casco e inmovilícelas con puntas A. Utilice un punzón para marcar el centro de cada orificio en el casco. Después, realice todos los orificios. Proceda de la misma manera en el otro lateral del casco. Inserte y pegue una pieza M4 en cada orificio. Elabore y fije las piezas N1 en el casco. Coloque el casco sobre una superficie plana y estable y asegúrese de que está inmovilizado. Construya un útil con listones y realícele un orificio para insertar un rotulador o lápiz a la altura indicada en las imágenes. Trace la línea a todo el contorno del barco. Después, enmascare el casco con cinta de carroceros y papel y pinte la parte inferior del casco con pintura de color rojo, (Ref.19383). Esta operación puede realizarla a pincel o con aerógrafo. Siguiendo el mismo proceso de enmascarado y pintado, pinte el casco con el color negro, (Ref.19301) y gris, (Ref.19386), como le muestran las imágenes.

O-P-Q-R-S-T. Lije y forre las cubiertas que le indican las imágenes. Observe con detenimiento como deben quedar acabadas para no dejar cerrados o abiertos orificios que va a necesitar más adelante. Después, aplíqueles barniz, (Ref.19209). Construya las estructuras que le muestran las imágenes. Asegúrese de que quedan bien alineadas. Después, pegue las cubiertas encima de cada estructura. Algunas de las estructuras, deberá lijarlas y enmasillarlas para dejarlas finas.

U-V. Utilice las hojas IP para identificar las piezas de latón. Extraiga las piezas y elimine los restos de unión. Después, vaya pegándolas en los lugares indicados en las imágenes. Después de colocar los paneles de latón, deberá ir añadiendo los detalles como puertas, ventanas y demás piezas que se le indican en las imágenes. Continúe construyendo las estructuras que le indican las imágenes. Enmasille aquellas estructuras que se le indican en las imágenes. Para poder pintar las estructuras, primero enmascare las cubiertas con cinta de carroceros y papel. Aplique imprimación, (Ref.19142), y resérvelas hasta que se sequen. Después, aplíqueles pintura de color gris claro, (Ref.19384). Construya los radares, antenas y demás estructuras que le indican las imágenes. Después, aplique imprimación y pintura del color gris, (Ref.19384) a las estructuras que se le van indicando.

W-X-Y-Z. Presente la base de la superestructura mediante las piezas W1 en la cubierta principal, pero no lo pegue. Solamente es para que vea el ajuste y sepa como deberá quedar. Después, retire la base del casco y continúe con la construcción de las piezas. Toda la superestructura y las piezas que van sobre ella y sobre las cubiertas deberá pintarlas del mismo color gris, (Ref.19384). Deberá ir construyendo conjuntos, como chimeneas, radares, cañones y demás piezas e ir añadiéndolas al barco cuando las imágenes así se lo muestren. Construya la plantilla PL-04 que es la planta completa del barco y utilícela para situar las piezas. Continúe construyendo la superestructura añadiendo las piezas ya pintadas que le indican las fotos. Marque y pinte la parte delantera y superior del casco con el color gris, (Ref.19385). Construya y decore las piezas de la parte inferior del casco y fíjelas. Corte unas tiras del vinilo blanco sobrante de las banderas y colóquelos en la parte delantera del casco. Añada el resto de piezas que las fotos y la plantilla le indican. Para fijar los hilos de los mástiles, aplique un poco de cola en su extremo y fíjelo mediante una pinza para inmovilizarlo hasta que se seque. Después, retire las pinzas.

A-B-C. On a flat, stable surface glue parts A1 and A2. Reinforce the joint using parts A3. Following the alphanumeric order insert and glue the parts as shown in the illustrations. Before gluing the frames, check that they fit correctly in their position by fitting them into the corresponding sockets of the false keel. It is important that the frames are completely perpendicular to the false keel so that the decks fit well afterwards. Use white glue for this operation, (Ref.19200). Cut the C26 parts to size. Position them as shown in the picture and mark the part that protrudes from the base. Make a recess so that when you place them in the structure, they fit as shown.

D. Cut to size and glue the D1 reinforcements at the front of the false keel against the frames. Cut out the shape of template PL-01 and glue it in front. Use a cutter to remove excess from the reinforcements. Then, smooth them down with a file. Glue together the other pieces shown in the pictures. Offer up template PL-01 on deck D5 and draw the lines shown in the image. Find the centre of the deck and draw lines across the deck every 60 mm. Adjust and glue the decks D5 to D8 and continue drawing the lines to complete the hull.

E. Cut the E1 liner strips to size and highlight their edges with a pencil. Start lining the deck by adjusting the first plate to the line shown in the image. Glue the strips close together so that the joints are not visible. Use contact glue, (shoemaker's glue). Press the strips along the length of the deck so that they adhere firmly. Line the entire deck and make the holes in the deck so as not to lose sight of them. Then cut the excess from the strips with a cutter. Sand the deck until its surface is smooth and even. Then remove the dust from the sanding and apply satin varnish, (Ref.19209).

F. Glue parts F1 and F2 together by aligning them along their straight parts. Glue the assemblies obtained flush with the last frame of the skeleton. Cut out the two paper templates and glue them as shown in the picture. Place the hull upside down and start sanding starting from stern to bow. Smooth the edges of the frames, but without spoiling their original shape. Sand until you reach the curves of the templates. The hull must be sanded symmetrically; that is, the right side must be identical to the left. When sanding the central part of the hull, use a sanding block with larger surface area. Sanding must be progressive and smooth. In the bow area, start sanding from the bow and work your way to the stern. Use a straight edge to check that you are sanding correctly. To do so, you must slide the edge over the frames, to see how it fits its shape.

G-H-i. Start the lining the hull with the G1 slats. If the slats are very dry and break when you bend them, soak them in water for twenty minutes. This will make them flexible. Then, dry them with a cloth. You must glue the first slat fitted to the foredeck and flush at the top. Use white glue, (Ref.19200) or quick glue, (Ref.19201). Then, fix it using A-pins. Glue two more G1 planks to give continuity to the first strake to the stern of the hull. The other planks of the lining must be glued to the frames and to each other, using white glue and fixed with pins. Continue gluing planks from bow to stern to line the entire hull. You will need to cut to them size and adjust them to fit the gaps. Offer up parts i1, i2, i3, i4, i5 and i6 to the hull to see how you should adjust the lining, taking into account that there will also be a second 0.6 mm thick lining. If at any planks are loose, apply quick-drying glue. If one or more planks are lower than the others and you have some planks left, stick them on the recessed ones and then sand them down. File the heads of the pins using a flat file until they are flush with the lining. Dilute some white glue with water so you can apply it sparingly and it will creep between the plank joints. Immobilise the hull until the adhesive dries. This operation fixes the whole hull lining, strengthening it. Then, sand the entire hull. It should be smooth and even. Apply contact glue, (shoemaker's glue), to the area of the hull shown in the images. Glue lining strips i7. You must join the i7 strips to complete the full length of the hull. Cut to size the lining strips depending on the need. Press the lining strips along their length so that they adhere firmly. Glue parts i1 to i6 definitively and adjust them to the lining using a file.

J-K-L. Turn the hull upside down and apply filler putty, (Ref. 19143), to fill in any gaps that may have been left between slats. Apply it along the entire length of the hull to unify its surfaces and cover possible faults. When it has dried, sand the hull until it is very smooth. It is advisable to mask the deck with paper and masking tape to protect it from the dust. Apply primer (Ref.19142), to the entire surface of the hull. When it has dried, finish the hull with a fine sanding sponge and repeat the filling and priming process until it is smooth and even. To make the rudders, you must use photoengraved brass pieces. Remove them from the sheet with a knife and remove the remains of the joining nerves with a file. Apply primer the completed rudders. Prepare the rudder post following the step-by-step instructions.

M-N. Cut out templates PL-02 and PL-03 and paste the portions obtained as shown in the illustrations. Place the templates on the hull and fix them using A-pins. Use a punch to mark the centre of each hole in the hull. Then make all the holes. Do the same on the other side of the hull. Insert and glue one M4 piece into each hole. Prepare and secure the N1 parts to the hull. Put the hull on a flat, stable surface and fix it in place. Build a tool using slats and make a hole so you can insert a marker or pencil at the position shown in the illustration. Draw the line around the entire the ship. Then, mask the hull with masking tape and paper and paint the bottom of the hull with red paint, (Ref.19383). This can be done using brush or airbrush. Following the same masking and painting process, paint the hull black, (Ref.19301) and gray, (Ref.19386), as shown in the illustrations.

O-P-Q-R-S-T. Sand and line the decks as shown in the pictures. Carefully observe how they must be finished so as not to leave closed or open holes that you will need later. Then apply varnish, (Ref.19209). Build the structures shown in the pictures. Make sure they are properly aligned. Then, glue the decks on top of each structure. Some of the structures must be sanded and filled until they are smooth.

U-V. Use sheets I and P to identify the brass parts. Remove the parts and remove any remaining excess material. Then, fit them in the positions shown in the illustration. After placing the brass panels, add the details such as doors, windows and other parts shown in the illustrations. Continue to build the structures shown in the pictures. Mask the structures that as shown in the illustrations. To paint the structures, first mask the decks with masking tape and paper. Apply primer, (Ref.19142), and set aside until dry. Then, paint light grey (Ref.19384). Build the radars, antennas and other structures shown in the illustrations. Then, apply grey primer and paint (Ref.19384) the structures indicated.

W-X-Y-Z. Offer up the base of the superstructure using the W1 parts on the main deck, but do not glue it. This is simply to see how it fits and see what it should look like. Then remove the base of the hull and continue building the parts. All the superstructure and the parts fitted to it and on the decks must be painted the same grey colour, (Ref.19384). You must build sets, such as chimneys, radars, cannons and other pieces and add them to the ship as shown in the illustrations. Build template PL-04 which is the complete plan of the boat and use it to position the pieces. Continue building the superstructure by adding the pieces already painted shown in the photos. Mark and paint the front and top of the hull grey, (Ref.19385). Build and decorate the parts at the lower part of the hull and attach them. Cut a few strips of the white vinyl leftover from the flags and place them on the front of the hull. Add the rest of the pieces shown in the photos and the template.

To fix the mast rigging, apply a little glue at the end of the thread and immobilize with a clamp it until it dries. Then remove the clamp.

A-B-C. Utilisez une surface plane et stable pour coller les pièces A1 et A2. Renforcez leur union à l'aide des pièces A3. Suivant l'ordre alphanumérique, insérez et collez les pièces indiquées sur les images. Avant de coller les couples, vérifiez qu'ils s'ajustent correctement à leur place et font office de « taquet » dans les emboîtements correspondants de la fausse quille. Il est important que les couples restent totalement perpendiculaires à la fausse quille afin que les ponts viennent s'emboîter correctement par la suite. Pour ces opérations, utilisez comme adhésif de la colle blanche (Réf. 19200). Découpez aux dimensions les pièces C26. Placez-les comme le montre l'image et marquez la partie qui dépasse de la base. Réalisez une rainure pour qu'au moment de les installer sur la structure, ils restent à la mesure indiquée.

D. Découpez aux dimensions et collez les renforts D1 sur la partie avant de la fausse-queue contre les couples. Découpez la figure du modèle PL-01 et collez-la devant. Utilisez un cutter pour dégrossir les renforts. Puis, repassez-les avec une lime. Collez les autres pièces indiquées sur les images. Présentez la figure du modèle PL-01 sur le pont D5 et tracez les lignes qui sont indiquées sur l'image. Trouvez le milieu du pont et marquez des lignes transversales sur le pont tous les 60 mm. Ajustez et collez les ponts D5 et D8 et continuez à tracer les lignes pour compléter la totalité de la coque.

E. Découpez les bandes du bordé E1 aux dimensions, et marquez ses chants à l'aide d'un crayon noir. Commencez à border le pont en ajustant la première planche sur la ligne comme indiqué sur l'image. Collez les lattes de manière très rapprochée, afin que les unions ne se remarquent pas. Utilisez la colle de contact (colle de cordonnier). Appuyez en lissant les lattes du pont afin qu'elles adhèrent fermement. Bordez tout le pont et ouvrez petit à petit les orifices du pont pour ne pas les perdre de vue. Puis coupez les excédents des lattes à l'aide d'un cutter. Poncez le pont jusqu'à ce que la surface soit fine et homogène. Puis, éliminez la poussière après ponçage, et appliquez le vernis satiné (Réf. 19209).

F. Collez entre elles les pièces F1 et F2 en les alignant par leurs côtés droits. Collez les ensembles obtenus au ras du dernier couple de la charpente. Découpez les deux bases en papier et collez-les comme indiqué sur l'image. Placez la coque à l'envers et commencez à poncer en allant de la poupe à la proue. Vous devez dégrossir les renforts et les arêtes des couples mais sans déformer leur forme originale. Poncez jusqu'à la courbure des bases. Le ponçage de la coque doit être symétrique, c'est-à-dire, que le côté droit doit être identique au gauche. Pour la zone du milieu de la coque, utilisez une cale à poncer de plus grande surface. Le ponçage doit être progressif et doux. Dans la zone de la proue, commencez par poncer de la proue en avançant vers la poupe. Vérifiez à l'aide d'un listeau que le ponçage est correct. Pour cela, faites glisser le listeau sur les couples pour vérifier qu'il s'ajuste à leur forme.

G-H-i. Commencez le bordage de la coque à l'aide des lattes G1. Si les lattes sont très sèches et se cassent quand on les plie, plongez-les dans l'eau pendant 20 minutes environ. Avec cette opération, elles gagneront en souplesse. Puis, séchez-les à l'aide d'un chiffon. Vous devez coller la première latte sur le pont de proue et à ras de sa partie supérieure. Utilisez de la colle blanche (Réf. 19200) ou de la colle rapide (Réf. 19201). Puis, vous devrez la clouer avec des pointes A. Collez une autre latte G1 dans le prolongement de la première jusqu'à l'arrière de la coque. Les autres lattes du bordé doivent être collées aux couples, et entre elles, avec de la colle blanche puis fixées avec des pointes. Poursuivez en collant les lattes, de la proue à la poupe pour border la coque en entier. Vous devrez couper sur mesure et ajuster les pièces pour qu'elles s'emboîtent dans les zones creuses. Présentez les pièces i1, i2, i3, i4, i5 et i6 sur la coque, pour vérifier comment vous devez ajuster le bordé en tenant compte du fait qu'il faudra un deuxième bordé de 0,6 mm d'épaisseur. Si quelque part une latte n'est pas fixée, vous pouvez appliquer de la colle à séchage rapide. Si vous voyez une latte plus enfoncée, collez-en une autre par-dessus puis poncez. Limez les têtes des pointes à l'aide d'une lime jusqu'à ce qu'elle soit au ras du bordé. Diluez un peu de colle blanche dans de l'eau afin de l'appliquer légèrement, et qu'elle pénètre entre les jointures des lattes. Mettez la coque de côté, jusqu'à ce que la colle sèche. Avec cette opération, le bordé de la coque sera unifié, ce qui lui fera gagner en consistance. Puis poncez toute la coque. Elle doit être douce et régulière. Appliquez de la colle de contact (colle de cordonnier) sur la zone de la coque indiquée sur les images. Encollez et collez les lattes du bordé i7. Vous devez combiner des lattes i7 pour compléter la longueur totale de la coque. Découpez sur mesure les lattes du bordé en fonction des besoins. Appuyez en lissant sur les lattes du bordé afin qu'elles adhèrent fermement. Collez les pièces i1 et i6 définitivement et adaptez à l'aide d'une lime au bordé.

J-K-L. Placez la coque à l'envers et appliquez du mastic anti-fissures (réf. 19143), pour remplir les espaces qui peuvent apparaître entre les lattes. Appliquez-en sur toute la longueur de la coque pour unifier ses surfaces et couvrir d'éventuels défauts. Lorsqu'il aura séché, poncez la coque pour obtenir une surface fine. Il est conseillé de protéger la coque avec du papier et du ruban de masquage, pour la protéger de la poussière de ponçage. Appliquez l'apprêt (Réf. 19142) sur toute la surface de la coque. Lorsqu'il sera sec, polissez la coque à l'aide d'une éponge de ponçage fine, puis appliquez à nouveau du mastic et de l'apprêt jusqu'à obtenir une finition fine et uniforme. Pour élaborer les timons, vous devrez utiliser des pièces en laiton marquées par photogravure. Les extraire de la planche à l'aide d'un cutter, et éliminez les restes des nerfs d'union à l'aide d'une lime diamantée. Appliquez l'apprêt sur les timons une fois qu'ils seront construits. Élaborez les étambots de la coque en suivant les indications pas à pas.

M-N. Découpez les bases PL-02 et PL-03 et collez les portions obtenues comme indiqué sur les images. Présentez les bases sur la coque et immobilisez-les à l'aide des pointes A. Utilisez un poinçon pour marquer le milieu de chaque orifice sur la coque. Puis, réalisez tous les orifices. Procédez de la même manière sur l'autre côté de la coque. Insérez et collez la pièce M4 sur chaque orifice. Élaborez et fixez les pièces N1 sur la coque. Placez la coque sur une surface plane et stable et assurez-vous qu'elle est immobilisée. Construisez un outil à l'aide des listeaux et exécutez un orifice pour y insérer un feutre ou un crayon noir à la hauteur indiquée sur les images. Tracez la ligne sur tout le contour du bateau. Puis, protégez la coque avec du ruban de masquage et du papier, et peignez la partie inférieure de la coque avec de la peinture de couleur rouge (Réf. 19383). Cette opération peut être réalisée à l'aide d'un pinceau ou d'un aérographe. Suivant le même processus de masquage et de peinture, peignez la coque de couleur noire (Réf. 19301) et grise, (Réf. 19386), comme le montrent les images.

O-P-Q-R-S-T. Poncez et bordez les ponts que vous indiquent les images. Observez avec attention comment doivent apparaître les finitions pour ne laisser les orifices que vous allez utiliser ultérieurement ni ouverts ni fermés. Ensuite, appliquez dessus du vernis (Réf. 19209). Construisez les structures que vous montrent les images. Assurez-vous qu'elles sont bien alignées. Puis, collez les ponts sur chaque structure. Certaines des structures doivent être poncées et recouvertes de mastic pour que leur aspect soit fin.

U-V. Utilisez les feuilles IP pour identifier les pièces en laiton. Extraire les pièces et éliminer les restes des unions. Puis, collez-les dans les lieux indiqués sur les images. Après avoir placé les panneaux de laiton, vous devrez ajouter les éléments tels que les portes, les fenêtres et autres pièces indiquées sur les images. Continuez à construire les structures indiquées sur les images. Appliquez du mastic sur les structures indiquées sur les images. Pour pouvoir peindre les structures, protégez d'abord les ponts avec du ruban de masquage et du papier. Appliquez l'apprêt (Réf. 19142) et mettez de côté jusqu'au séchage. Puis, appliquez la peinture gris clair (Réf. 19384). Construisez les radars, antennes et autres éléments indiqués sur les images. Puis appliquez l'apprêt et la peinture de couleur grise (Réf. 19384) sur les éléments qui vous sont indiqués.

W-X-Y-Z. Présentez la base de la superstructure à l'aide des pièces W1 sur le pont principal, mais ne la collez pas. Ce n'est que pour voir comment elle s'adapte et savoir comment elle doit apparaître. Puis, retirez la base de la coque et continuez la construction des pièces. Toute la superstructure et les pièces qui vont sur elle et sur les ponts devront être peintes de la même couleur grise (Réf. 19384). Vous devrez construire des ensembles, tels que les cheminées, les radars, les canons et autres éléments et les ajouter sur le bateau comme le montrent les images le montrent. Construisez la base PL-04 qui est la base complète du bateau et utilisez-la pour placer les pièces. Continuez en construisant la superstructure en ajoutant les pièces déjà peintes indiquées sur les photos. Marquez et peignez la partie avant et supérieure de la coque de couleur grise (Réf. 19385). Construisez et décidez les pièces de la partie inférieure de la coque et fixez-les. Découpez des bandes de vinyles blanc sur les restes des drapeaux et placez-les sur la partie avant de la coque. Ajoutez le reste des pièces comme indiqué sur les photos et le modèle.

Pour fixer les fils des mâts, appliquez un peu de colle à leur extrémité et fixez-les à l'aide d'une pince pour les immobiliser jusqu'à ce qu'ils sèchent. Puis retirez les pinces.

A-B-C. Incollare i pezzi A1 e A2 su una superficie piana e stabile. Rafforzare la loro unione con i pezzi A3. Seguendo l'ordine alfanumerico, inserire e incollare i pezzi indicati nelle immagini. Prima di incollare le coste, verificare che si inseriscano correttamente in posizione incastrandole nei corrispondenti incavi della falsa chiglia. È importante che le coste siano completamente perpendicolari alla falsa chiglia in modo che i ponti si incastrino correttamente. Per queste operazioni utilizzare come collante la colla bianca (Rif. 19200). Tagliare a misura i pezzi C26, posizionarli come mostrato nell'immagine e segnare la parte che sporge dalla base. Realizzare un incavo in modo che, quando si posizionano sulla struttura, abbiano le stesse dimensioni che sono indicate.

D. Tagliare a misura e incollare i rinforzi D1 sulla parte anteriore della falsa chiglia contro le coste. Ritagliare la figura dal modello PL-01 e incollarla sulla parte anteriore. Utilizzare un cutter per sgrossare i rinforzi. Quindi limarli con una lima. Incollare le altre parti indicate nelle immagini. Posizionare la sagoma PL-01 sul ponte D5 e tracciare le linee indicate nella figura. Individuare il centro del ponte e tracciare le linee ogni 60 mm. Incollare i ponti da D5 a D8 e continuare a tracciare le linee per completare lo scafo.

E. Tagliare a misura le strisce di rivestimento E1 ed evidenziarne i bordi con una matita. Iniziare a rivestire il ponte adattando il primo foglio alla linea mostrata nell'immagine. Incollare le strisce vicine in modo che le giunzioni non siano visibili. Utilizzare come collante la colla a contatto (colla per ciabattini). Strofinare le strisce contro il ponte in modo che aderiscano saldamente. Rivestire l'intero ponte e aprire i fori del ponte in modo da non perderli di vista. Tagliare quindi le strisce in eccesso con un taglierino. Carteggiare la coperta fino a ottenere una superficie fine e uniforme. Rimuovere la polvere di carteggiatura e applicare la vernice satinata (Rif. 19209).

F. Incollare i pezzi F1 e F2 allineandoli sui lati diritti. Incollare i gruppi ottenuti a filo dell'ultima costa dello scheletro. Ritagliare le due sagome di carta e incollarle come mostrato nell'immagine. Capovolgere lo scafo e iniziare a carteggiare partendo da poppa e lavorando verso prua. È necessario irruvidire i rinforzi e i bordi delle coste, ma senza deformare la loro forma originale. Carteggiare fino alle curve delle sagome. Lo scafo deve essere carteggiato in modo simmetrico, cioè il lato destro deve essere uguale a quello sinistro. Per la parte centrale dello scafo, utilizzare un blocco di carteggiatura con una superficie maggiore. La carteggiatura deve essere progressiva e uniforme. Nella zona della prua, iniziare a carteggiare dalla prua e procedere verso poppa. Controllare che la carteggiatura sia corretta utilizzando un'asta. A tal fine, far scorrere l'asta sulle coste per vedere come si adatta alla loro forma.

G-H-I. Iniziare a rivestire lo scafo con i listelli G1. Se i listelli sono troppo secchi e si rompono quando vengono piegati, immergerli in acqua per circa 20 minuti. Questo li renderà di nuovo elastici. Successivamente, asciugarli con un panno. Il primo listello deve essere incollato a filo del ponte di prua e a filo della parte superiore. Utilizzare colla bianca (Rif. 19200) o colla rapida (Rif. 19201). Incollare un altro listello G1 per continuare il primo listello fino alla parte posteriore dello scafo. I restanti listelli del fasciame devono essere incollati alle coste e tra loro con colla bianca e inchiodati in posizione con chiodi. Continuare a incollare i listelli da prua a poppa per rivestire l'intero scafo. Sarà necessario tagliare a misura e incastrare i pezzi nei fori. Disporre i pezzi i1, i2, i3, i4, i5 e i6 sullo scafo per vedere come deve essere il listello, tenendo presente che ci sarà anche un secondo listello di 0,6 mm di spessore. Se in qualche punto i listelli sono allentati, si può applicare della colla ad asciugatura rapida. Se ci sono altri listelli che si afflosciano, incollatene un altro e poi carteggiatelo. Limare le teste dei chiodi con una lima piatta finché non sono a filo con il rivestimento. Diluite un po' di colla bianca con acqua, in modo che possa essere applicata leggermente e filtrare tra le giunzioni dei listelli. Mettere da parte lo scafo finché la colla non si asciuga. Questa operazione uniformerà il fasciame dello scafo e lo renderà più consistente. Quindi carteggiare l'intero scafo. Dovrebbe essere liscio e uniforme. Applicare la colla a contatto (colla per ciabattini) sull'area dello scafo mostrata nelle immagini. Incollare le strisce di rivestimento i7. È necessario combinare le strisce i7 per completare la lunghezza totale dello scafo. Tagliare le strisce di rivestimento nella misura desiderata. Strofinare le strisce di rivestimento in modo che aderiscano saldamente. Incollare i pezzi da i1 a i6 in modo permanente e adattarli con una lima al rivestimento.

J-K-L. Capovolgere lo scafo e applicare lo stucco per crepe (Rif. 19143) per riempire eventuali spazi vuoti tra i listelli. Applicarlo su tutta la lunghezza dello scafo per uniformare le superfici dello scafo e coprire eventuali difetti. Una volta asciutto, carteggiare lo scafo fino a ottenere una finitura fine. Si consiglia di mascherare la coperta con carta e nastro adesivo per proteggerla dalla polvere di lucidatura. Applicare il primer (Rif. 19142) su tutta la superficie dello scafo. Una volta asciutto, lucidare lo scafo con carta abrasiva fine e ripetere il processo di mascheratura e primer fino a quando lo scafo sia liscio e uniforme. Per realizzare i timoni si devono utilizzare parti in ottone fotocinse. Rimuoverli dalla lastra con un cutter e rimuovere le nervature residue con una lima. Stampare i timoni una volta costruiti. Realizzare le ruote di poppa dello scafo seguendo le istruzioni passo-passo.

M-N. Ritagliare le sagome PL-02 e PL-03 e incollare le porzioni ottenute come mostrato nelle immagini. Presentare le sagome sullo scafo e immobilizzarle con i chiodi A. Con un punteruolo segnare il centro di ogni foro sullo scafo. Eseguire quindi tutti i fori. Procedere allo stesso modo sull'altro lato dello scafo. Inserire e incollare un pezzo M4 in ogni foro. Realizzare e fissare le parti N1 sullo scafo. Posizionare lo scafo su una superficie piana e stabile e assicurarsi che sia immobilizzato. Realizzare uno strumento in listelli e praticarvi un foro per inserire un pennarello o una matita all'altezza indicata nelle immagini. Tracciare la linea lungo tutto il perimetro della barca. Mascherare quindi lo scafo con nastro adesivo e carta e dipingere la parte inferiore dello scafo con vernice rossa (Rif. 19383). Questa operazione può essere eseguita a pennello o con l'aerografo. Seguendo lo stesso processo di mascheratura e verniciatura, dipingere lo scafo con il nero (Rif. 19301) e il grigio (Rif. 19386), come mostrato nelle immagini.

O-P-Q-R-S-T. Carteggiare e rivestire i ponti come mostrato nelle immagini. Osservare attentamente come devono essere rifiniti per non lasciare fori aperti o chiusi che serviranno in seguito. Applicare quindi la vernice (Rif. 19209). Realizzare le strutture mostrate nelle immagini. Assicurarsi che siano ben allineate. Incollare quindi i ponti su ogni struttura. Alcune strutture dovranno essere carteggiate e calafatate per renderle lisce.

U-V. Utilizzare le schede IP per identificare le parti in ottone. Estrarre le parti e rimuovere i residui di giunzione. Quindi incollarle nei punti indicati nelle immagini. Dopo aver posizionato i pannelli di ottone, è necessario aggiungere i dettagli come porte, finestre e altre parti come mostrato nelle immagini. Continuare a realizzare le strutture indicate nelle immagini. Mascherare le strutture indicate nelle immagini. Per poter dipingere le strutture, mascherare prima i ponti con nastro adesivo e carta. Applicare il primer (Rif. 19142) e lasciarlo asciugare. Applicare quindi la vernice grigio chiaro (Rif. 19384). Costruire i radar, le antenne e le altre strutture come mostrato nelle immagini. Applicare quindi il primer e la vernice grigia (Rif. 19384) sulle strutture che verranno indicate.

W-X-Y-Z. Presentare la base della sovrastruttura utilizzando i pezzi W1 del ponte principale, ma non incollarla. Questo solo per poter vedere l'incastro e sapere come dovrebbe apparire. Rimuovere quindi la base dello scafo e proseguire con la costruzione dei pezzi. Tutte le sovrastrutture e le parti che si trovano su di esse e sui ponti devono essere dipinte con lo stesso colore grigio (Rif. 19384). Dovrete costruire set come fumaioli, radar, cannoni e altre parti e aggiungerle alla nave quando le immagini lo mostreranno. Realizzare la sagoma PL-04, che rappresenta il piano completo della nave, e utilizzarla per posizionare i pezzi. Continuare a costruire la sovrastruttura aggiungendo le parti dipinte come mostrato nelle immagini. Segnare e dipingere la parte anteriore e superiore dello scafo con il colore grigio (Rif. 19385). Costruire e decorare i pezzi della parte inferiore dello scafo e fissarli. Tagliare alcune strisce del vinile bianco rimasto dalle bandiere e posizionarle sulla parte anteriore dello scafo. Aggiungere il resto dei pezzi come mostrato nelle foto e nella sagoma. Per fissare le cime degli alberi, applicare un po' di colla all'estremità e fissarla con un morsetto per immobilizzarla finché non si asciuga. Quindi rimuovere i morsetti.

A-B-C. A1 und A2 auf einer ebenen, stabilen Fläche zusammenkleben. Die Verbindung mit den Teilen A3 verstärken. Die auf den Abbildungen gezeigten Teile in der angegebenen Reihenfolge einsetzen und aufkleben. Vor dem Aufkleben der Spanten sicherstellen, dass die sie korrekt sitzen und mit den dazugehörigen Einkerbungen des falschen Kiels abschließen. Die Spanten müssen vollkommen senkrecht auf dem falschen Kiel stehen, damit danach die Decks gut eingesetzt werden können. Für diese Schritte weißen Leim (Ref.19200) verwenden. Die Teile C26 nach Maß zurechtschneiden. Wie auf der Abbildung gezeigt platzieren und den Teil markieren, der aus dem Unterbau herausragt. Passend zurechtstutzen, damit die Teile beim Einsetzen in die Struktur die angegebene Größe haben.

D. Die Verstärkungen D1 zurechtschneiden und an der Vorderseite des falschen Kiels an die Spanten kleben. Die Figur aus Schablone PL-01 ausschneiden und an die Vorderseite kleben. Mit einem Cutter die Verstrebungen glätten. Anschließend mit einer Feile nachbearbeiten. Die anderen Teile, die auf den Bildern zu sehen sind, aufkleben. Die Schablone PL-01 auf Deck D5 setzen und die auf der Abbildung gezeigten Linien einzeichnen. Die Mitte des Decks ermitteln und alle 60 mm Linien auf dem Deck markieren. Die Decks D5 bis D8 anpassen und aufkleben und weitere Linien einzeichnen, bis der gesamten Rumpf fertig ist.

E. Die Plankenreihe E1 nach Maß zurechtschneiden und die Kanten mit einem Bleistift hervorheben. Mit dem Beplanken des Decks beginnen und die erste Leiste an der markierten Linie ausrichten. Die Leisten eng zusammenkleben, damit keine Zwischenräume zu sehen sind. Zum Kleben Kontaktkleber verwenden (Schusterleim). Die Leisten an das Deck drücken, damit sie fest sitzen. Das gesamte Deck verkleiden und dabei die Öffnungen am Deck aufmachen, damit keine übersehen wird. Anschließend die überstehenden Teile mit einem Cutter abschneiden. Das Deck glatt feilen, so dass eine glatte und gleichmäßige Oberfläche entsteht. Anschließend den Schleifstaub entfernen und Satinlack auftragen (Ref. 19209).

F. Die Teile F1 und F2 aneinander kleben und an ihren geraden Seiten ausrichten. Die so erhaltenen Baugruppen bündig zum letzten Spanten des Schiffsskeletts aufkleben. Die beiden Papierstücke aus der Vorlage ausschneiden und wie auf der Abbildung gezeigt als Halbkreis aufkleben. Dies dient als Schablone. Den Rumpf mit der Oberseite nach unten anbringen und vom Heck in Richtung Bug glatt schleifen. Die Verstrebungen und die Kanten der Spanten glätten, ohne dabei das ursprüngliche Profil zu verändern. Bis auf die Höhe der Papierhalbkreise abschleifen. Beim Glätten des Rumpfs darauf achten, dass beide Seiten symmetrisch zueinander sein müssen. Für den mittleren Rumpfbereich einen Sander mit großer Schleifoberfläche verwenden. Die Oberfläche nach und nach vorsichtig glätten. Im Bugbereich vom Bug in Richtung Heck glattschleifen. Mit der Leiste testen, ob eine gleichmäßige Oberfläche hergestellt wurde. Dazu die Leiste über die Spanten fahren und prüfen, wie sie sich der Form anpasst.

G-H-I. Zuerst den Schiffsrumpf mit den Leisten G1 beplanken. Wenn die Leisten sehr trocken sind, ca. 20 Minuten in Wasser einweichen, damit sie nicht brechen. Damit werden sie biegsamer. Anschließend mit einem Tuch trockenreiben. Die erste Leiste fest mit dem Deck vom Vorderdeck verleimen, so dass sie bündig mit der Oberseite abschließt. Dazu weißen Leim (Ref.19200) oder Sekundenkleber (Ref.19201) verwenden. Danach mit A-Stiften befestigen. Eine weitere Leiste G1 an die erste setzen, die bis zum hinteren Ende des Rumpfs reicht. Die übrigen Leisten an die Spanten und aneinander kleben und mit weißem Leim und Stiften befestigen. Die Beplankung des Rumpfs fortsetzen und Leisten von Bug nach Heck aufkleben. Die Teile für die Zwischenräume nach Maß zurechtschneiden. Die Teile i1, i2, i3, i4, i5 und i6 auf dem Rumpf platzieren, um zu sehen, wie die Beplankung angepasst werden muss, dabei bedenken, dass es noch eine zweite Beplankung mit 0,6 mm Dicke geben wird. Lose Planken bei Bedarf mit Sekundenkleber festkleben. Wenn eine Planke zu tief eingesunken ist, eine weitere Planke darübersetzen und abschleifen. Die Stiftköpfe mit einer Feile glattfeilen, bis sie auf einer Höhe mit den Plankenreihen sind. Etwas weißen Leim mit Wasser verdünnen, um ihn leichter auftragen zu können, so dass er sich in den Zwischenräume zwischen den Leisten verteilt. Rumpf beiseite stellen, bis der Leim getrocknet ist. Mit diesem Verfahren wird die Rumpfbeplankung verbunden und gewinnt an Stabilität. Anschließend den gesamten Rumpf glatt schmirgeln. Es muss eine glatte und gleichmäßige Oberfläche entstehen. Kontaktkleber (Schusterleim) auf die Rumpfbereiche auftragen, die auf den Abbildungen zu sehen sind. Die Plankenreihe i7 mit Leim bestreichen und aufkleben. Die Leisten i7 kombinieren, um die Gesamtlänge des Rumpfs abzudecken. Die Plankenreihen passend zurechtschneiden. Die Plankenreihen fest andrücken, damit sie haften. Die Teile i1 bis i6 dauerhaft zusammenkleben und mit einer Feile an die Beplankung anpassen.

J-K-L. Den Rumpf umdrehen und Fugenkitt (Ref. 19143) auftragen, um eventuelle Lücken zwischen den Leisten zu füllen. Den Kitt über die gesamte Länge des Rumpfes auftragen, um eine gleichmäßige Oberfläche zu erzeugen und mögliche Fehler zu überdecken. Nach dem Trocknen den Rumpf fein schmirgeln. Es ist ratsam, das Deck mit Papier und Kreppband abzukleben, um ihn vor Polierstaub zu schützen. Grundierung (Ref.19142) auf die gesamte Oberfläche des Rumpfes auftragen. Nach dem Trocknen den Rumpf mit einem Schmirgelschwamm nachbearbeiten und anschließend den Füll- und Grundierungsvorgang wiederholen, bis eine gleichmäßige, glatte Oberfläche entstanden ist. Für die Herstellung der Ruder photogeätzte Messingteile verwenden. Die Teile mit einem Cutter aus der Platte lösen und Reste der Verbindungsglaschen mit einer Dreiecksfeile entfernen. Die Ruder nach dem Zusammenbauen mit Grundierung lackieren. Die Achtersteven des Rumpfs gemäß der Schritt-für-Schritt-Anleitung anfertigen.

M-N. Die Teile PL-02 und PL-03 als Schablonen ausschneiden und wie auf den Abbildungen gezeigt aufkleben. Die Schablonen auf den Rumpf setzen und mit den Stiften befestigen. Mit einem Stichel oder einem anderen spitzen Werkzeug die Stellen markieren, an denen dann die Öffnungen angebracht werden. Anschließend die Öffnungen anbringen. Auf der anderen Seite des Rumpfs ebenso verfahren. Ein Teil M4 in jede Öffnung einsetzen und aufkleben. Die Teile N1 anfertigen und am Rumpf befestigen. Den Rumpf auf eine flache, stabile Unterlage setzen und gut fixieren. Ein Werkzeug aus Leisten anfertigen und eine Öffnung anbringen, um einen Filzstift oder Bleistift in der auf den Abbildungen angegebenen Höhe einzuführen. Die Linie rund um das Schiffsmodell ziehen. Anschließend den Rumpf mit Kreppband und Papier abkleben und den unteren Teil des Rumpfes rot lackieren (Ref.19383). Dazu Pinsel oder Airbrush verwenden. Nach dem gleichen Verfahren (Abkleben) den Rumpf mit schwarzer (Ref. 19301) und grauer (Ref. 19386) Farbe lackieren, wie auf den Abbildungen gezeigt.

O-P-Q-R-S-T. Die Abdeckungen wie auf den Abbildungen gezeigt glatt schmirgeln und verkleiden. Darauf achten, wie die fertigen Decks aussehen sollen, damit keine Öffnungen, die in späteren Schritten gebracht werden, offenen oder geschlossenen bleiben. Anschließend Lack auftragen (Ref.19209). Die Strukturen, die auf den Abbildungen zu sehen sind, zusammenbauen. Sicherstellen, dass die Teile passend aufeinander sitzen. Anschließend die Decks auf die einzelnen Strukturen kleben. Einige der Strukturen müssen geschliffen und mit Fugenkitt behandelt werden, um damit eine glatte, gleichmäßige Oberfläche entsteht.

U-V. Die IP-Blätter verwenden, um die Messingteile zu identifizieren. Die benötigten Teile herauslösen und die Verbindungsglaschen entfernen. Die Teile auf die auf den Abbildungen gezeigten Stellen kleben.

Nach Anbringen der Messingplatten kleine Elemente wie Türen, Fenster und andere Teile hinzufügen, wie auf den Abbildungen gezeigt. Die Strukturen, die auf den Abbildungen zu sehen sind, zusammenbauen. Die auf den Abbildungen gezeigten Strukturen mit Kitt bestreichen. Um die Strukturen bemalen zu können, zunächst die Decks mit Kreppband und Papier abkleben. Grundierung (Ref. 19142) auftragen und zum Trocknen beiseite stellen. Anschließend hellgraue Farbe (Ref. 19384) auftragen. Radargeräte, Antennen und andere Strukturen, die auf den Abbildungen gezeigt sind, anfertigen. Grundierung und graue Farbe (Ref.19384) wie auf den Abbildungen gezeigt auf die Strukturen auftragen.

W-X-Y-Z. Die Basis der oberen Struktur mit den Teilen W1 auf dem Hauptdeck platzieren, aber nicht festkleben. Dieser Schritt dient dazu, die richtige Passform zu prüfen. Anschließend die Basis des Rumpfs entfernen und mit dem Bau der Teile fortfahren. Der gesamte Aufbau und die Teile darüber und auf den Decks in der gleichen grauen Farbe lackieren (Ref. 19384). Baugruppen wie Schornsteine, Radar, Kanonen und andere Teile anfertigen und sie wie auf den Abbildungen gezeigt in das Modell einsetzen. Die Schablone PL-04, die den kompletten Plan des Schiffs darstellt, verwenden, um die Teile zu platzieren. Zum Aufbau die auf den Abbildungen gezeigten lackierten Teile hinzufügen. Die Vorderseite und die Oberseite des Rumpfs markieren und mit grauer Farbe (Ref. 19385) lackieren. Die Teile des unteren Rumpfs anfertigen und befestigen. Streifen aus dem weißen Vinyl, das von den Flaggen übrig geblieben ist, zurechtschneiden und auf die Vorderseite des Rumpfs anbringen. Die restlichen auf den Fotos gezeigten Teile entsprechend der Schablone hinzufügen. Um die Fäden der Masten zu befestigen, jeweils etwas Kleber auf das Mastende auftragen und den Faden dann mit einer Klammer fixieren, bis der Kleber getrocknet ist. Anschließend die Klammern wieder abnehmen.

<i>Lista de piezas / Parts List / Liste des pièces / Teileliste / Elenco delle parti</i>			
N°/No./ N° / Nr. No	Cantidad / Quantity / Quantité / Menge / Quantità	Medidas / Measurements / Dimensions /Maße / Misure	Material / Material / Matériau / Material / Materiale
A1	1	Precortado / Precut / Prédécoupé / Vorgeschnitten / Pretagliato / Pretagliato	Tablero / Plywood / Planche / Sperrholz / Tavola
A2	1	Precortado / Precut / Prédécoupé / Vorgeschnitten / Pretagliato / Pretagliato	Tablero / Plywood / Planche / Sperrholz / Tavola
A3	1	Precortado / Precut / Prédécoupé / Vorgeschnitten / Pretagliato / Pretagliato	Tablero / Plywood / Planche / Sperrholz / Tavola
B1	1	Precortado / Precut / Prédécoupé / Vorgeschnitten / Pretagliato	Tablero / Plywood / Planche / Sperrholz / Tavola
B2	1	Precortado / Precut / Prédécoupé / Vorgeschnitten / Pretagliato	Tablero / Plywood / Planche / Sperrholz / Tavola
B3	4	Precortado / Precut / Prédécoupé / Vorgeschnitten / Pretagliato	Tablero / Plywood / Planche / Sperrholz / Tavola
B4	1	Precortado / Precut / Prédécoupé / Vorgeschnitten / Pretagliato	Tablero / Plywood / Planche / Sperrholz / Tavola
B5-B6	2	Precortado / Precut / Prédécoupé / Vorgeschnitten / Pretagliato	Tablero / Plywood / Planche / Sperrholz / Tavola
C1-C22	22	Precortado / Precut / Prédécoupé / Vorgeschnitten / Pretagliato	Tablero / Plywood / Planche / Sperrholz / Tavola
C23-C25	6	Precortado / Precut / Prédécoupé / Vorgeschnitten / Pretagliato	Tablero / Plywood / Planche / Sperrholz / Tavola
C26	16	22x25x48	Balsa / Balsa / Balsa / Balsaholz / Balsa
D1	6	22x25x88	Balsa / Balsa / Balsa / Balsaholz / Balsa
D2	2	22x25x62	Balsa / Balsa / Balsa / Balsaholz / Balsa
D3	6	22x25x56	Balsa / Balsa / Balsa / Balsaholz / Balsa
D4	2	22x25x43	Balsa / Balsa / Balsa / Balsaholz / Balsa
D5-D8	4	Precortado / Precut / Prédécoupé / Vorgeschnitten / Pretagliato	Tablero / Plywood / Planche / Sperrholz / Tavola
E1	940	1x3x60	Tilo / Lime wood / Tilleul / Linde / Tiglio
F1	6	Precortado / Precut / Prédécoupé / Vorgeschnitten / Pretagliato	Tablero / Plywood / Planche / Sperrholz / Tavola
F2	2	Precortado / Precut / Prédécoupé / Vorgeschnitten / Pretagliato	Tablero / Plywood / Planche / Sperrholz / Tavola
F3	1	2x5x600	Tilo / Lime wood / Tilleul / Linde / Tiglio
G1	17	2x5x600	Tilo / Lime wood / Tilleul / Linde / Tiglio
H1	100	2x5x600	Tilo / Lime wood / Tilleul / Linde / Tiglio
i1	1	Preformado / Prefomed/ Préformé / Vorgeformt / Preformato	Metal / Metal / Metal / Metall / Metallo
i2-i3	2	Preformado / Prefomed/ Préformé / Vorgeformt / Preformato	Metal / Metal / Metal / Metall / Metallo
i4-i5	2	Preformado / Prefomed/ Préformé / Vorgeformt / Preformato	Metal / Metal / Metal / Metall / Metallo
i6	2	Preformado / Prefomed/ Préformé / Vorgeformt / Preformato	Madera / Wood / Bois / Holz / Legno
i7	100	0,6x7x600	Sicomoro / Sycamore / Sycomore / Bergahom / Sicomoro
K1	2	Precortado / Precut / Prédécoupé / Vorgeschnitten / Pretagliato	Tablero / Plywood / Planche / Sperrholz / Tavola
K2	2	Precortado / Precut / Prédécoupé / Vorgeschnitten / Pretagliato	Tablero / Plywood / Planche / Sperrholz / Tavola
K3	2	Preformado / Prefomed/ Préformé / Vorgeformt / Preformato	Tablero / Plywood / Planche / Sperrholz / Tavola
K4	2	ø1x15	Latón / Brass / Latón / Messing / Ottone
K5	2	ø1x30	Latón / Brass / Latón / Messing / Ottone
K6-K8	12	Preformado / Prefomed/ Préformé / Vorgeformt / Preformato	Latón / Brass / Latón / Messing / Ottone
L1	2	22x25x200	Balsa / Balsa / Balsa / Balsaholz / Balsa
L2	2	Precortado / Precut / Prédécoupé / Vorgeschnitten / Pretagliato	Tablero / Plywood / Planche / Sperrholz / Tavola
L3	2	2x5x200	Tilo / Lime wood / Tilleul / Linde / Tiglio
L4	2	2x5x150	Tilo / Lime wood / Tilleul / Linde / Tiglio
M1	1	Preformado / Prefomed/ Préformé / Vorgeformt / Preformato	Latón / Brass / Latón / Messing / Ottone
M2	1	Preformado / Prefomed/ Préformé / Vorgeformt / Preformato	Latón / Brass / Latón / Messing / Ottone
M3	2	Preformado / Prefomed/ Préformé / Vorgeformt / Preformato	Metal / Metal / Metal / Metall / Metallo
M4	100	Preformado / Prefomed/ Préformé / Vorgeformt / Preformato	Composite / Composite / Composite / Composite / Composite
N1	2	2x5x365	Tilo / Lime wood / Tilleul / Linde / Tiglio
O1	1	Precortado / Precut / Prédécoupé / Vorgeschnitten / Pretagliato	Tablero / Plywood / Planche / Sperrholz / Tavola
O2	798	1x3x60	Tilo / Lime wood / Tilleul / Linde / Tiglio
O3	1	Precortado / Precut / Prédécoupé / Vorgeschnitten / Pretagliato	Tablero / Plywood / Planche / Sperrholz / Tavola
O4	1	Precortado / Precut / Prédécoupé / Vorgeschnitten / Pretagliato	Tablero / Plywood / Planche / Sperrholz / Tavola
O5	1	Precortado / Precut / Prédécoupé / Vorgeschnitten / Pretagliato	Tablero / Plywood / Planche / Sperrholz / Tavola
P1	2	Precortado / Precut / Prédécoupé / Vorgeschnitten / Pretagliato	Tablero / Plywood / Planche / Sperrholz / Tavola
P2-P3	2	Precortado / Precut / Prédécoupé / Vorgeschnitten / Pretagliato	Tablero / Plywood / Planche / Sperrholz / Tavola
P4-P8	8	Precortado / Precut / Prédécoupé / Vorgeschnitten / Pretagliato	Tablero / Plywood / Planche / Sperrholz / Tavola
P9	2	2x5x50	Tilo / Lime wood / Tilleul / Linde / Tiglio
Q1	1	Precortado / Precut / Prédécoupé / Vorgeschnitten / Pretagliato	Tablero / Plywood / Planche / Sperrholz / Tavola
Q2-Q3	2	Precortado / Precut / Prédécoupé / Vorgeschnitten / Pretagliato	Tablero / Plywood / Planche / Sperrholz / Tavola
Q4-Q6	4	Precortado / Precut / Prédécoupé / Vorgeschnitten / Pretagliato	Tablero / Plywood / Planche / Sperrholz / Tavola
Q7	2	2x5x50	Tilo / Lime wood / Tilleul / Linde / Tiglio

Lista de piezas / Parts List / Liste des pièces / Teilleiste / Elenco delle parti

N°/No./ Nº / Nr. No	Cantidad / Quantity / Quantité / Menge / Quantità	Medidas / Measurements / Dimensions /Maße / Misure	Material / Material / Matériau / Material / Materiale
U140-U143	4	Preformado / Prefomed/ Préformé / Vorgeformt / Prefomato	Latón / Brass / Latón / Messing / Ottone
U144	1	Preformado / Prefomed/ Préformé / Vorgeformt / Prefomato	Latón / Brass / Latón / Messing / Ottone
U145	2	Preformado / Prefomed/ Préformé / Vorgeformt / Prefomato	Latón / Brass / Latón / Messing / Ottone
U146	1	Preformado / Prefomed/ Préformé / Vorgeformt / Prefomato	Latón / Brass / Latón / Messing / Ottone
U147-U149	3	Preformado / Prefomed/ Préformé / Vorgeformt / Prefomato	Latón / Brass / Latón / Messing / Ottone
U150	11	Preformado / Prefomed/ Préformé / Vorgeformt / Prefomato	Latón / Brass / Latón / Messing / Ottone
U151	1	Preformado / Prefomed/ Préformé / Vorgeformt / Prefomato	Latón / Brass / Latón / Messing / Ottone
U152-U154	4	Preformado / Prefomed/ Préformé / Vorgeformt / Prefomato	Latón / Brass / Latón / Messing / Ottone
U155	1	Precortado / Precut / Prédécoupé / Vorgeschnitten / Pretagliatto	Tablero / Plywood / Planche / Sperrholz / Tavola
U156	1	Preformado / Prefomed/ Préformé / Vorgeformt / Prefomato	Latón / Brass / Latón / Messing / Ottone
U157-U160	4	Preformado / Prefomed/ Préformé / Vorgeformt / Prefomato	Latón / Brass / Latón / Messing / Ottone
U161	1	Precortado / Precut / Prédécoupé / Vorgeschnitten / Pretagliatto	Tablero / Plywood / Planche / Sperrholz / Tavola
U162-U164	5	Preformado / Prefomed/ Préformé / Vorgeformt / Prefomato	Latón / Brass / Latón / Messing / Ottone
U165	1	Precortado / Precut / Prédécoupé / Vorgeschnitten / Pretagliatto	Tablero / Plywood / Planche / Sperrholz / Tavola
U166	1	Precortado / Precut / Prédécoupé / Vorgeschnitten / Pretagliatto	Tablero / Plywood / Planche / Sperrholz / Tavola
U167-U171	6	Preformado / Prefomed/ Préformé / Vorgeformt / Prefomato	Latón / Brass / Latón / Messing / Ottone
U171	1	Precortado / Precut / Prédécoupé / Vorgeschnitten / Pretagliatto	Tablero / Plywood / Planche / Sperrholz / Tavola
U172	1	Preformado / Prefomed/ Préformé / Vorgeformt / Prefomato	Latón / Brass / Latón / Messing / Ottone
U173	2	Precortado / Precut / Prédécoupé / Vorgeschnitten / Pretagliatto	Tablero / Plywood / Planche / Sperrholz / Tavola
U174	2	Preformado / Prefomed/ Préformé / Vorgeformt / Prefomato	Latón / Brass / Latón / Messing / Ottone
U175	2	Precortado / Precut / Prédécoupé / Vorgeschnitten / Pretagliatto	Tablero / Plywood / Planche / Sperrholz / Tavola
U176-U184	10	Preformado / Prefomed/ Préformé / Vorgeformt / Prefomato	Latón / Brass / Latón / Messing / Ottone
U185-U189	6	Preformado / Prefomed/ Préformé / Vorgeformt / Prefomato	Latón / Brass / Latón / Messing / Ottone
U190	1	Preformado / Prefomed/ Préformé / Vorgeformt / Prefomato	Latón / Brass / Latón / Messing / Ottone
U191	2	Preformado / Prefomed/ Préformé / Vorgeformt / Prefomato	Latón / Brass / Latón / Messing / Ottone
V1-V8	8	Precortado / Precut / Prédécoupé / Vorgeschnitten / Pretagliatto	Tablero / Plywood / Planche / Sperrholz / Tavola
V9	2	12x12x22	Balsa / Balsa / Balsa / Balsaholz / Balsa
V10	2	12x12x19	Balsa / Balsa / Balsa / Balsaholz / Balsa
V11-V18	8	Preformado / Prefomed/ Préformé / Vorgeformt / Prefomato	Latón / Brass / Latón / Messing / Ottone
V19	2	Preformado / Prefomed/ Préformé / Vorgeformt / Prefomato	Latón / Brass / Latón / Messing / Ottone
V20-V21	2	Preformado / Prefomed/ Préformé / Vorgeformt / Prefomato	Latón / Brass / Latón / Messing / Ottone
V22	1	Preformado / Prefomed/ Préformé / Vorgeformt / Prefomato	Latón / Brass / Latón / Messing / Ottone
V23	2	Preformado / Prefomed/ Préformé / Vorgeformt / Prefomato	Latón / Brass / Latón / Messing / Ottone
V24-V25	2	Preformado / Prefomed/ Préformé / Vorgeformt / Prefomato	Latón / Brass / Latón / Messing / Ottone
V26	2	Preformado / Prefomed/ Préformé / Vorgeformt / Prefomato	Latón / Brass / Latón / Messing / Ottone
V27	1	Preformado / Prefomed/ Préformé / Vorgeformt / Prefomato	Latón / Brass / Latón / Messing / Ottone
V28-V29	2	Preformado / Prefomed/ Préformé / Vorgeformt / Prefomato	Latón / Brass / Latón / Messing / Ottone
V30-V31	2	Preformado / Prefomed/ Préformé / Vorgeformt / Prefomato	Latón / Brass / Latón / Messing / Ottone
V32	2	Preformado / Prefomed/ Préformé / Vorgeformt / Prefomato	Latón / Brass / Latón / Messing / Ottone
V33	2	Preformado / Prefomed/ Préformé / Vorgeformt / Prefomato	Latón / Brass / Latón / Messing / Ottone
V34	2	Preformado / Prefomed/ Préformé / Vorgeformt / Prefomato	Latón / Brass / Latón / Messing / Ottone
V35	1	Preformado / Prefomed/ Préformé / Vorgeformt / Prefomato	Latón / Brass / Latón / Messing / Ottone
V36	1	Preformado / Prefomed/ Préformé / Vorgeformt / Prefomato	Latón / Brass / Latón / Messing / Ottone
V37	2	Preformado / Prefomed/ Préformé / Vorgeformt / Prefomato	Latón / Brass / Latón / Messing / Ottone
V38	8	ø0,50x30	Latón / Brass / Latón / Messing / Ottone
V39-V40	4	Preformado / Prefomed/ Préformé / Vorgeformt / Prefomato	Metal / Metal / Metal / Metall / Metallo
V42-V43	4	Precortado / Precut / Prédécoupé / Vorgeschnitten / Pretagliatto	Tablero / Plywood / Planche / Sperrholz / Tavola
V44	2	Preformado / Prefomed/ Préformé / Vorgeformt / Prefomato	Latón / Brass / Latón / Messing / Ottone
V45	2	Preformado / Prefomed/ Préformé / Vorgeformt / Prefomato	Metal / Metal / Metal / Metall / Metallo
V46	6	Preformado / Prefomed/ Préformé / Vorgeformt / Prefomato	Metal / Metal / Metal / Metall / Metallo
V47	1	ø1x20	Latón / Brass / Latón / Messing / Ottone
V48	1	Preformado / Prefomed/ Préformé / Vorgeformt / Prefomato	Metal / Metal / Metal / Metall / Metallo
V49	2	Preformado / Prefomed/ Préformé / Vorgeformt / Prefomato	Latón / Brass / Latón / Messing / Ottone
V50	2	Preformado / Prefomed/ Préformé / Vorgeformt / Prefomato	Latón / Brass / Latón / Messing / Ottone
V51	2	Preformado / Prefomed/ Préformé / Vorgeformt / Prefomato	Latón / Brass / Latón / Messing / Ottone

Lista de piezas / Parts List / Liste des pièces / Teileliste / Elenco delle parti

Nº/No./ Nº / Nr. No	Cantidad / Quantity / Quantité / Menge / Quantità	Medidas / Measurements / Dimensions /Maße / Misure	Material / Material / Matériau / Material / Materiale
V52	2	Preformado / Prefomed/ Préformé / Vorgeformt / Preformato	Latón / Brass / Latón / Messing / Ottone
V53	3	Preformado / Prefomed/ Préformé / Vorgeformt / Preformato	Latón / Brass / Latón / Messing / Ottone
V54	1	Preformado / Prefomed/ Préformé / Vorgeformt / Preformato	Latón / Brass / Latón / Messing / Ottone
V55	1	Preformado / Prefomed/ Préformé / Vorgeformt / Preformato	Latón / Brass / Latón / Messing / Ottone
V56-V58	3	Preformado / Prefomed/ Préformé / Vorgeformt / Preformato	Latón / Brass / Latón / Messing / Ottone
V59-V60	2	Preformado / Prefomed/ Préformé / Vorgeformt / Preformato	Latón / Brass / Latón / Messing / Ottone
V61-V62	2	Preformado / Prefomed/ Préformé / Vorgeformt / Preformato	Latón / Brass / Latón / Messing / Ottone
V63	1	Preformado / Prefomed/ Préformé / Vorgeformt / Preformato	Latón / Brass / Latón / Messing / Ottone
V64	1	Preformado / Prefomed/ Préformé / Vorgeformt / Preformato	Latón / Brass / Latón / Messing / Ottone
V65	1	ø0,50x100	Latón / Brass / Latón / Messing / Ottone
V66	2	Preformado / Prefomed/ Préformé / Vorgeformt / Preformato	Metal / Metal / Metal / Metall / Metallo
V67	4	Preformado / Prefomed/ Préformé / Vorgeformt / Preformato	Metal / Metal / Metal / Metall / Metallo
V68	30	Preformado / Prefomed/ Préformé / Vorgeformt / Preformato	Metal / Metal / Metal / Metall / Metallo
V69	2	ø1x25	Latón / Brass / Latón / Messing / Ottone
V70	2	Preformado / Prefomed/ Préformé / Vorgeformt / Preformato	Latón / Brass / Latón / Messing / Ottone
V71	2	Preformado / Prefomed/ Préformé / Vorgeformt / Preformato	Latón / Brass / Latón / Messing / Ottone
V72	4	Preformado / Prefomed/ Préformé / Vorgeformt / Preformato	Metal / Metal / Metal / Metall / Metallo
V73	2	Preformado / Prefomed/ Préformé / Vorgeformt / Preformato	Metal / Metal / Metal / Metall / Metallo
V74	2	Preformado / Prefomed/ Préformé / Vorgeformt / Preformato	Latón / Brass / Latón / Messing / Ottone
V75-V78	20	Preformado / Prefomed/ Préformé / Vorgeformt / Preformato	Latón / Brass / Latón / Messing / Ottone
V79	4	Preformado / Prefomed/ Préformé / Vorgeformt / Preformato	Metal / Metal / Metal / Metall / Metallo
V80	2	Preformado / Prefomed/ Préformé / Vorgeformt / Preformato	Latón / Brass / Latón / Messing / Ottone
V81	2	Preformado / Prefomed/ Préformé / Vorgeformt / Preformato	Latón / Brass / Latón / Messing / Ottone
V82-V83	2	Preformado / Prefomed/ Préformé / Vorgeformt / Preformato	Latón / Brass / Latón / Messing / Ottone
V84-V85	3	Preformado / Prefomed/ Préformé / Vorgeformt / Preformato	Latón / Brass / Latón / Messing / Ottone
V86-V89	4	Preformado / Prefomed/ Préformé / Vorgeformt / Preformato	Latón / Brass / Latón / Messing / Ottone
V90	1	Precortado / Precut / Prédécoupé / Vorgeschnitten / Pretagliato	Tablero / Plywood / Planche / Sperrholz / Tavola
V91	1	Preformado / Prefomed/ Préformé / Vorgeformt / Preformato	Latón / Brass / Latón / Messing / Ottone
V92	1	Precortado / Precut / Prédécoupé / Vorgeschnitten / Pretagliato	Tablero / Plywood / Planche / Sperrholz / Tavola
V93	1	Preformado / Prefomed/ Préformé / Vorgeformt / Preformato	Latón / Brass / Latón / Messing / Ottone
V94	1	Preformado / Prefomed/ Préformé / Vorgeformt / Preformato	Latón / Brass / Latón / Messing / Ottone
V95-V96	2	Preformado / Prefomed/ Préformé / Vorgeformt / Preformato	Latón / Brass / Latón / Messing / Ottone
V97	1	Precortado / Precut / Prédécoupé / Vorgeschnitten / Pretagliato	Tablero / Plywood / Planche / Sperrholz / Tavola
V98	2	Preformado / Prefomed/ Préformé / Vorgeformt / Preformato	Latón / Brass / Latón / Messing / Ottone
V99	2	Preformado / Prefomed/ Préformé / Vorgeformt / Preformato	Latón / Brass / Latón / Messing / Ottone
V100	1	Preformado / Prefomed/ Préformé / Vorgeformt / Preformato	Metal / Metal / Metal / Metall / Metallo
V101	1	Preformado / Prefomed/ Préformé / Vorgeformt / Preformato	Metal / Metal / Metal / Metall / Metallo
V102	1	Preformado / Prefomed/ Préformé / Vorgeformt / Preformato	Metal / Metal / Metal / Metall / Metallo
V103	1	Preformado / Prefomed/ Préformé / Vorgeformt / Preformato	Metal / Metal / Metal / Metall / Metallo
V104	1	Preformado / Prefomed/ Préformé / Vorgeformt / Preformato	Latón / Brass / Latón / Messing / Ottone
V105	1	Preformado / Prefomed/ Préformé / Vorgeformt / Preformato	Latón / Brass / Latón / Messing / Ottone
V106	2	Preformado / Prefomed/ Préformé / Vorgeformt / Preformato	Latón / Brass / Latón / Messing / Ottone
V107	1	Preformado / Prefomed/ Préformé / Vorgeformt / Preformato	Latón / Brass / Latón / Messing / Ottone
V108	2	Preformado / Prefomed/ Préformé / Vorgeformt / Preformato	Latón / Brass / Latón / Messing / Ottone
V109	1	Preformado / Prefomed/ Préformé / Vorgeformt / Preformato	Latón / Brass / Latón / Messing / Ottone
V110	2	Preformado / Prefomed/ Préformé / Vorgeformt / Preformato	Latón / Brass / Latón / Messing / Ottone
V111-V112	4	Preformado / Prefomed/ Préformé / Vorgeformt / Preformato	Latón / Brass / Latón / Messing / Ottone
V113	1	Preformado / Prefomed/ Préformé / Vorgeformt / Preformato	Latón / Brass / Latón / Messing / Ottone
V114-V115	2	Preformado / Prefomed/ Préformé / Vorgeformt / Preformato	Latón / Brass / Latón / Messing / Ottone
V116-V117	4	Preformado / Prefomed/ Préformé / Vorgeformt / Preformato	Latón / Brass / Latón / Messing / Ottone
V118-V119	2	Preformado / Prefomed/ Préformé / Vorgeformt / Preformato	Latón / Brass / Latón / Messing / Ottone
V120	5	ø1x4	Latón / Brass / Latón / Messing / Ottone
V121	1	Preformado / Prefomed/ Préformé / Vorgeformt / Preformato	Metal / Metal / Metal / Metall / Metallo
V122-V123	2	Preformado / Prefomed/ Préformé / Vorgeformt / Preformato	Metal / Metal / Metal / Metall / Metallo
V124-V127	4	Preformado / Prefomed/ Préformé / Vorgeformt / Preformato	Latón / Brass / Latón / Messing / Ottone

Lista de piezas / Parts List / Liste des pièces / Teileliste / Elenco delle parti

Nº/No./ Nº / Nr. No	Cantidad / Quantity / Quantité / Menge / Quantità	Medidas / Measurements / Dimensions /Maße / Misure	Material / Material / Matériau / Material / Materiale
V128-V129	2	Preformado / Prefomed/ Préformé / Vorgeformt / Preformato	Metal / Metal / Metal / Metall / Metallo
V130-V131	2	Preformado / Prefomed/ Préformé / Vorgeformt / Preformato	Latón / Brass / Latón / Messing / Ottone
V132	2	Preformado / Prefomed/ Préformé / Vorgeformt / Preformato	Metal / Metal / Metal / Metall / Metallo
V133	32	ø1x5	Latón / Brass / Latón / Messing / Ottone
W1	2	Precortado / Precut / Prédécoupé / Vorgeschnitten / Pretagliatto	Tablero / Plywood / Planche / Sperrholz / Tavola
W2	8	Preformado / Prefomed/ Préformé / Vorgeformt / Preformato	Latón / Brass / Latón / Messing / Ottone
W3-W4	2	Preformado / Prefomed/ Préformé / Vorgeformt / Preformato	Latón / Brass / Latón / Messing / Ottone
W5-W6	2	Preformado / Prefomed/ Préformé / Vorgeformt / Preformato	Latón / Brass / Latón / Messing / Ottone
W7	2	Preformado / Prefomed/ Préformé / Vorgeformt / Preformato	Latón / Brass / Latón / Messing / Ottone
W8	1	Preformado / Prefomed/ Préformé / Vorgeformt / Preformato	Metal / Metal / Metal / Metall / Metallo
W9	3	Preformado / Prefomed/ Préformé / Vorgeformt / Preformato	Metal / Metal / Metal / Metall / Metallo
W10	55	Preformado / Prefomed/ Préformé / Vorgeformt / Preformato	Metal / Metal / Metal / Metall / Metallo
W11	2	Preformado / Prefomed/ Préformé / Vorgeformt / Preformato	Metal / Metal / Metal / Metall / Metallo
W12	5	Preformado / Prefomed/ Préformé / Vorgeformt / Preformato	Metal / Metal / Metal / Metall / Metallo
W13	1	Preformado / Prefomed/ Préformé / Vorgeformt / Preformato	Metal / Metal / Metal / Metall / Metallo
W14	3	Preformado / Prefomed/ Préformé / Vorgeformt / Preformato	Metal / Metal / Metal / Metall / Metallo
W15	1	Preformado / Prefomed/ Préformé / Vorgeformt / Preformato	Latón / Brass / Latón / Messing / Ottone
W16	3	Preformado / Prefomed/ Préformé / Vorgeformt / Preformato	Latón / Brass / Latón / Messing / Ottone
W17	48	Preformado / Prefomed/ Préformé / Vorgeformt / Preformato	Latón / Brass / Latón / Messing / Ottone
W18	3	Preformado / Prefomed/ Préformé / Vorgeformt / Preformato	Latón / Brass / Latón / Messing / Ottone
W19	48	Preformado / Prefomed/ Préformé / Vorgeformt / Preformato	Metal / Metal / Metal / Metall / Metallo
W20-W21	2	Preformado / Prefomed/ Préformé / Vorgeformt / Preformato	Metal / Metal / Metal / Metall / Metallo
W22-W23	2	Preformado / Prefomed/ Préformé / Vorgeformt / Preformato	Latón / Brass / Latón / Messing / Ottone
W24	1	2x5x15	Tilo / Lime wood / Tilleul / Linde / Tiglio
W25	1	Preformado / Prefomed/ Préformé / Vorgeformt / Preformato	Latón / Brass / Latón / Messing / Ottone
W26	1	Precortado / Precut / Prédécoupé / Vorgeschnitten / Pretagliatto	Tablero / Plywood / Planche / Sperrholz / Tavola
W27	6	Preformado / Prefomed/ Préformé / Vorgeformt / Preformato	Latón / Brass / Latón / Messing / Ottone
W28	2	ø1x20	Latón / Brass / Latón / Messing / Ottone
W29	2	2x5x8	Tilo / Lime wood / Tilleul / Linde / Tiglio
W30-W31	2	Preformado / Prefomed/ Préformé / Vorgeformt / Preformato	Latón / Brass / Latón / Messing / Ottone
W32-W34	5	Precortado / Precut / Prédécoupé / Vorgeschnitten / Pretagliatto	Tablero / Plywood / Planche / Sperrholz / Tavola
W35-W37	4	Precortado / Precut / Prédécoupé / Vorgeschnitten / Pretagliatto	Tablero / Plywood / Planche / Sperrholz / Tavola
W38-W41	6	Preformado / Prefomed/ Préformé / Vorgeformt / Preformato	Latón / Brass / Latón / Messing / Ottone
W42-W43	6	Preformado / Prefomed/ Préformé / Vorgeformt / Preformato	Latón / Brass / Latón / Messing / Ottone
W44-W45	8	Precortado / Precut / Prédécoupé / Vorgeschnitten / Pretagliatto	Tablero / Plywood / Planche / Sperrholz / Tavola
W46	4	2x5x5	Tilo / Lime wood / Tilleul / Linde / Tiglio
W47-W48	8	Precortado / Precut / Prédécoupé / Vorgeschnitten / Pretagliatto	Tablero / Plywood / Planche / Sperrholz / Tavola
W49-W51	8	Preformado / Prefomed/ Préformé / Vorgeformt / Preformato	Latón / Brass / Latón / Messing / Ottone
W52	20	Preformado / Prefomed/ Préformé / Vorgeformt / Preformato	Metal / Metal / Metal / Metall / Metallo
W53	20	Preformado / Prefomed/ Préformé / Vorgeformt / Preformato	Metal / Metal / Metal / Metall / Metallo
W54	20	Preformado / Prefomed/ Préformé / Vorgeformt / Preformato	Latón / Brass / Latón / Messing / Ottone
W55-W57	60	Preformado / Prefomed/ Préformé / Vorgeformt / Preformato	Latón / Brass / Latón / Messing / Ottone
W58	40	Preformado / Prefomed/ Préformé / Vorgeformt / Preformato	Metal / Metal / Metal / Metall / Metallo
W59	80	ø0,50x7	Latón / Brass / Latón / Messing / Ottone
W60	60	Preformado / Prefomed/ Préformé / Vorgeformt / Preformato	Metal / Metal / Metal / Metall / Metallo
W61	3	Preformado / Prefomed/ Préformé / Vorgeformt / Preformato	Metal / Metal / Metal / Metall / Metallo
W62	1	Preformado / Prefomed/ Préformé / Vorgeformt / Preformato	Metal / Metal / Metal / Metall / Metallo
W63	1	Preformado / Prefomed/ Préformé / Vorgeformt / Preformato	Metal / Metal / Metal / Metall / Metallo
W64	1	Preformado / Prefomed/ Préformé / Vorgeformt / Preformato	Metal / Metal / Metal / Metall / Metallo
W65	11	Preformado / Prefomed/ Préformé / Vorgeformt / Preformato	Metal / Metal / Metal / Metall / Metallo
W66	17	Preformado / Prefomed/ Préformé / Vorgeformt / Preformato	Metal / Metal / Metal / Metall / Metallo
W67-W69	42	Preformado / Prefomed/ Préformé / Vorgeformt / Preformato	Latón / Brass / Latón / Messing / Ottone
W70-W71	8	Preformado / Prefomed/ Préformé / Vorgeformt / Preformato	Latón / Brass / Latón / Messing / Ottone
W72	4	Preformado / Prefomed/ Préformé / Vorgeformt / Preformato	Metal / Metal / Metal / Metall / Metallo
W73	1	Preformado / Prefomed/ Préformé / Vorgeformt / Preformato	Metal / Metal / Metal / Metall / Metallo

Lista de piezas / Parts List / Liste des pièces / Teileliste / Elenco delle parti

N°/No./ Nº / Nr. No	Cantidad / Quantity / Quantité / Menge / Quantità	Medidas / Measurements / Dimensions /Maße / Misure	Material / Material / Matériau / Material / Materiale
W74	1	Preformado / Prefomed/ Préformé / Vorgeformt / Prefomato	Metal / Metal / Metal / Metall / Metallo
W75	2	Preformado / Prefomed/ Préformé / Vorgeformt / Prefomato	Metal / Metal / Metal / Metall / Metallo
W76	15	Preformado / Prefomed/ Préformé / Vorgeformt / Prefomato	Metal / Metal / Metal / Metall / Metallo
W77-W78	60	Preformado / Prefomed/ Préformé / Vorgeformt / Prefomato	Latón / Brass / Latón / Messing / Ottone
W79	34	Preformado / Prefomed/ Préformé / Vorgeformt / Prefomato	Latón / Brass / Latón / Messing / Ottone
W80	72	Preformado / Prefomed/ Préformé / Vorgeformt / Prefomato	Latón / Brass / Latón / Messing / Ottone
W81	2	Preformado / Prefomed/ Préformé / Vorgeformt / Prefomato	Latón / Brass / Latón / Messing / Ottone
W82	2	Preformado / Prefomed/ Préformé / Vorgeformt / Prefomato	Metal / Metal / Metal / Metall / Metallo
W83	5	ø1x25	Latón / Brass / Latón / Messing / Ottone
W84	2	Preformado / Prefomed/ Préformé / Vorgeformt / Prefomato	Metal / Metal / Metal / Metall / Metallo
W85	1	Preformado / Prefomed/ Préformé / Vorgeformt / Prefomato	Metal / Metal / Metal / Metall / Metallo
W86	2	Preformado / Prefomed/ Préformé / Vorgeformt / Prefomato	Metal / Metal / Metal / Metall / Metallo
W87	1	Preformado / Prefomed/ Préformé / Vorgeformt / Prefomato	Metal / Metal / Metal / Metall / Metallo
W88	1	Preformado / Prefomed/ Préformé / Vorgeformt / Prefomato	Metal / Metal / Metal / Metall / Metallo
W89	2	Preformado / Prefomed/ Préformé / Vorgeformt / Prefomato	Metal / Metal / Metal / Metall / Metallo
W90	1	Preformado / Prefomed/ Préformé / Vorgeformt / Prefomato	Metal / Metal / Metal / Metall / Metallo
W91	2	Preformado / Prefomed/ Préformé / Vorgeformt / Prefomato	Metal / Metal / Metal / Metall / Metallo
W92	2	Preformado / Prefomed/ Préformé / Vorgeformt / Prefomato	Metal / Metal / Metal / Metall / Metallo
W93-W94	2	Preformado / Prefomed/ Préformé / Vorgeformt / Prefomato	Metal / Metal / Metal / Metall / Metallo
W95	5	Preformado / Prefomed/ Préformé / Vorgeformt / Prefomato	Metal / Metal / Metal / Metall / Metallo
W96-W98	6	Preformado / Prefomed/ Préformé / Vorgeformt / Prefomato	Latón / Brass / Latón / Messing / Ottone
W99	1	Preformado / Prefomed/ Préformé / Vorgeformt / Prefomato	Latón / Brass / Latón / Messing / Ottone
W100	2	Preformado / Prefomed/ Préformé / Vorgeformt / Prefomato	Metal / Metal / Metal / Metall / Metallo
W101	1	Preformado / Prefomed/ Préformé / Vorgeformt / Prefomato	Latón / Brass / Latón / Messing / Ottone
W102	2	Preformado / Prefomed/ Préformé / Vorgeformt / Prefomato	Latón / Brass / Latón / Messing / Ottone
W103	2	ø1x6	Latón / Brass / Latón / Messing / Ottone
W104	3	Precortado / Precut / Prédécoupé / Vorgeschnitten / Pretagliato	Tablero / Plywood / Planche / Sperrholz / Tavola
X1	1	Preformado / Prefomed/ Préformé / Vorgeformt / Prefomato	Latón / Brass / Latón / Messing / Ottone
X2	2	ø1x21	Latón / Brass / Latón / Messing / Ottone
X3	2	Preformado / Prefomed/ Préformé / Vorgeformt / Prefomato	Latón / Brass / Latón / Messing / Ottone
X4-X5	2	Preformado / Prefomed/ Préformé / Vorgeformt / Prefomato	Metal / Metal / Metal / Metall / Metallo
X6	2	Preformado / Prefomed/ Préformé / Vorgeformt / Prefomato	Metal / Metal / Metal / Metall / Metallo
X7	2	Preformado / Prefomed/ Préformé / Vorgeformt / Prefomato	Metal / Metal / Metal / Metall / Metallo
X8	1	Preformado / Prefomed/ Préformé / Vorgeformt / Prefomato	Metal / Metal / Metal / Metall / Metallo
X9	2	Precortado / Precut / Prédécoupé / Vorgeschnitten / Pretagliato	Tablero / Plywood / Planche / Sperrholz / Tavola
X10	2	Preformado / Prefomed/ Préformé / Vorgeformt / Prefomato	Latón / Brass / Latón / Messing / Ottone
X11	2	Preformado / Prefomed/ Préformé / Vorgeformt / Prefomato	Metal / Metal / Metal / Metall / Metallo
X12	2	Preformado / Prefomed/ Préformé / Vorgeformt / Prefomato	Latón / Brass / Latón / Messing / Ottone
X13	2	ø1,5x44	Latón / Brass / Latón / Messing / Ottone
X14	2	Preformado / Prefomed/ Préformé / Vorgeformt / Prefomato	Metal / Metal / Metal / Metall / Metallo
X15-X18	4	Preformado / Prefomed/ Préformé / Vorgeformt / Prefomato	Metal / Metal / Metal / Metall / Metallo
X19	2	ø1,5x4	Latón / Brass / Latón / Messing / Ottone
X20	24	Preformado / Prefomed/ Préformé / Vorgeformt / Prefomato	Metal / Metal / Metal / Metall / Metallo
X21	4	Preformado / Prefomed/ Préformé / Vorgeformt / Prefomato	Metal / Metal / Metal / Metall / Metallo
X22	16	Preformado / Prefomed/ Préformé / Vorgeformt / Prefomato	Metal / Metal / Metal / Metall / Metallo
X23	1	Preformado / Prefomed/ Préformé / Vorgeformt / Prefomato	Metal / Metal / Metal / Metall / Metallo
X24	6	Preformado / Prefomed/ Préformé / Vorgeformt / Prefomato	Metal / Metal / Metal / Metall / Metallo
X25	1	Preformado / Prefomed/ Préformé / Vorgeformt / Prefomato	Metal / Metal / Metal / Metall / Metallo
X26	1	Preformado / Prefomed/ Préformé / Vorgeformt / Prefomato	Metal / Metal / Metal / Metall / Metallo
X27	6	Preformado / Prefomed/ Préformé / Vorgeformt / Prefomato	Metal / Metal / Metal / Metall / Metallo
X28	2	Preformado / Prefomed/ Préformé / Vorgeformt / Prefomato	Metal / Metal / Metal / Metall / Metallo
X29	4	Preformado / Prefomed/ Préformé / Vorgeformt / Prefomato	Metal / Metal / Metal / Metall / Metallo
X30	7	Preformado / Prefomed/ Préformé / Vorgeformt / Prefomato	Metal / Metal / Metal / Metall / Metallo
X31	15	Preformado / Prefomed/ Préformé / Vorgeformt / Prefomato	Latón / Brass / Latón / Messing / Ottone
X32-X33	4	Preformado / Prefomed/ Préformé / Vorgeformt / Prefomato	Latón / Brass / Latón / Messing / Ottone

Lista de piezas / Parts List / Liste des pièces / Teileliste / Elenco delle parti

N°/No./ Nº / Nr. No	Cantidad / Quantity / Quantité / Menge / Quantità	Medidas / Measurements / Dimensions /Maße / Misure	Material / Material / Matériau / Material / Materiale
X34	2	Preformado / Prefomed/ Préformé / Vorgeformt / Preformato	Metal / Metal / Metal / Metall / Metallo
X35	2	Preformado / Prefomed/ Préformé / Vorgeformt / Preformato	Metal / Metal / Metal / Metall / Metallo
X36	2	Preformado / Prefomed/ Préformé / Vorgeformt / Preformato	Latón / Brass / Latón / Messing / Ottone
X37	2	Preformado / Prefomed/ Préformé / Vorgeformt / Preformato	Latón / Brass / Latón / Messing / Ottone
X38	1	Preformado / Prefomed/ Préformé / Vorgeformt / Preformato	Metal / Metal / Metal / Metall / Metallo
X39	1	Precortado / Precut / Prédécoupé / Vorgeschnitten / Pretagliatto	Tablero / Plywood / Planche / Sperrholz / Tavola
X40	1	Preformado / Prefomed/ Préformé / Vorgeformt / Preformato	Latón / Brass / Latón / Messing / Ottone
X41	2	Precortado / Precut / Prédécoupé / Vorgeschnitten / Pretagliatto	Tablero / Plywood / Planche / Sperrholz / Tavola
X42	2	Preformado / Prefomed/ Préformé / Vorgeformt / Preformato	Latón / Brass / Latón / Messing / Ottone
X43	2	Precortado / Precut / Prédécoupé / Vorgeschnitten / Pretagliatto	Tablero / Plywood / Planche / Sperrholz / Tavola
X44	2	Preformado / Prefomed/ Préformé / Vorgeformt / Preformato	Latón / Brass / Latón / Messing / Ottone
X45	2	Precortado / Precut / Prédécoupé / Vorgeschnitten / Pretagliatto	Tablero / Plywood / Planche / Sperrholz / Tavola
X46	2	Preformado / Prefomed/ Préformé / Vorgeformt / Preformato	Latón / Brass / Latón / Messing / Ottone
X47	2	Preformado / Prefomed/ Préformé / Vorgeformt / Preformato	Latón / Brass / Latón / Messing / Ottone
X48-X52	20	Preformado / Prefomed/ Préformé / Vorgeformt / Preformato	Latón / Brass / Latón / Messing / Ottone
X53	2	Preformado / Prefomed/ Préformé / Vorgeformt / Preformato	Metal / Metal / Metal / Metall / Metallo
X54	2	Preformado / Prefomed/ Préformé / Vorgeformt / Preformato	Latón / Brass / Latón / Messing / Ottone
X55	2	Preformado / Prefomed/ Préformé / Vorgeformt / Preformato	Latón / Brass / Latón / Messing / Ottone
X56	1	Preformado / Prefomed/ Préformé / Vorgeformt / Preformato	Metal / Metal / Metal / Metall / Metallo
X57	2	Preformado / Prefomed/ Préformé / Vorgeformt / Preformato	Metal / Metal / Metal / Metall / Metallo
X58	4	Preformado / Prefomed/ Préformé / Vorgeformt / Preformato	Metal / Metal / Metal / Metall / Metallo
X59	4	ø0,50x25	Latón / Brass / Latón / Messing / Ottone
X60	2	Preformado / Prefomed/ Préformé / Vorgeformt / Preformato	Metal / Metal / Metal / Metall / Metallo
X61	4	2x5x7	Tilo / Lime wood / Tilleul / Linde / Tiglio
X62	1	Preformado / Prefomed/ Préformé / Vorgeformt / Preformato	Metal / Metal / Metal / Metall / Metallo
X63	1	Preformado / Prefomed/ Préformé / Vorgeformt / Preformato	Metal / Metal / Metal / Metall / Metallo
X64	2	Preformado / Prefomed/ Préformé / Vorgeformt / Preformato	Metal / Metal / Metal / Metall / Metallo
X65	14	2x6	Vinilo / Vinyl / Vinyle / Vinyl / Vinile
X66	2	2x3	Vinilo / Vinyl / Vinyle / Vinyl / Vinile
X67-X68	3	Preformado / Prefomed/ Préformé / Vorgeformt / Preformato	Latón / Brass / Latón / Messing / Ottone
Y1	2	Preformado / Prefomed/ Préformé / Vorgeformt / Preformato	Metal / Metal / Metal / Metall / Metallo
Y2-Y3	8	Preformado / Prefomed/ Préformé / Vorgeformt / Preformato	Metal / Metal / Metal / Metall / Metallo
Y4	2	ø1x15	Latón / Brass / Latón / Messing / Ottone
Y5	4	Preformado / Prefomed/ Préformé / Vorgeformt / Preformato	Latón / Brass / Latón / Messing / Ottone
Y6-Y7	6	Preformado / Prefomed/ Préformé / Vorgeformt / Preformato	Latón / Brass / Latón / Messing / Ottone
Y8	2	Preformado / Prefomed/ Préformé / Vorgeformt / Preformato	Metal / Metal / Metal / Metall / Metallo
Y9	2	Preformado / Prefomed/ Préformé / Vorgeformt / Preformato	Latón / Brass / Latón / Messing / Ottone
Y10	2	Preformado / Prefomed/ Préformé / Vorgeformt / Preformato	Metal / Metal / Metal / Metall / Metallo
Y11	2	Preformado / Prefomed/ Préformé / Vorgeformt / Preformato	Metal / Metal / Metal / Metall / Metallo
Y12	2	Preformado / Prefomed/ Préformé / Vorgeformt / Preformato	Latón / Brass / Latón / Messing / Ottone
Y13	2	Preformado / Prefomed/ Préformé / Vorgeformt / Preformato	Latón / Brass / Latón / Messing / Ottone
Y14	2	Preformado / Prefomed/ Préformé / Vorgeformt / Preformato	Metal / Metal / Metal / Metall / Metallo
Y15	2	Preformado / Prefomed/ Préformé / Vorgeformt / Preformato	Latón / Brass / Latón / Messing / Ottone
Y16	2	Preformado / Prefomed/ Préformé / Vorgeformt / Preformato	Latón / Brass / Latón / Messing / Ottone
Y17	2	Preformado / Prefomed/ Préformé / Vorgeformt / Preformato	Latón / Brass / Latón / Messing / Ottone
Y18	2	Preformado / Prefomed/ Préformé / Vorgeformt / Preformato	Latón / Brass / Latón / Messing / Ottone
Y19-Y23	6	Preformado / Prefomed/ Préformé / Vorgeformt / Preformato	Latón / Brass / Latón / Messing / Ottone
Y24-Y27	10	Preformado / Prefomed/ Préformé / Vorgeformt / Preformato	Latón / Brass / Latón / Messing / Ottone
Y28	1	ø0,50x10	Latón / Brass / Latón / Messing / Ottone
Y29	1	Preformado / Prefomed/ Préformé / Vorgeformt / Preformato	Metal / Metal / Metal / Metall / Metallo
Y30	1	ø0,50x100	Latón / Brass / Latón / Messing / Ottone
Y31	1	ø0,50x20	Latón / Brass / Latón / Messing / Ottone
Y32	1	ø0,50x30	Latón / Brass / Latón / Messing / Ottone
Y33	8	Preformado / Prefomed/ Préformé / Vorgeformt / Preformato	Vinilo / Vinyl / Vinyle / Vinyl / Vinile
Y34	10	Preformado / Prefomed/ Préformé / Vorgeformt / Preformato	Latón / Brass / Latón / Messing / Ottone

Lista de piezas / Parts List / Liste des pièces / Teileliste / Elenco delle parti

N°/No./ Nº / Nr. No	Cantidad / Quantity / Quantité / Menge / Quantità	Medidas / Measurements / Dimensions /Maße / Misure	Material / Material / Matériau / Material / Materiale
Y35	10	ø1x22	Latón / Brass / Latón / Messing / Ottone
Y36	10	Preformado / Prefomed/ Préformé / Vorgeformt / Preformato	Latón / Brass / Latón / Messing / Ottone
Y37-Y38	20	Preformado / Prefomed/ Préformé / Vorgeformt / Preformato	Latón / Brass / Latón / Messing / Ottone
Y39	10	Preformado / Prefomed/ Préformé / Vorgeformt / Preformato	Latón / Brass / Latón / Messing / Ottone
Y40	20	Preformado / Prefomed/ Préformé / Vorgeformt / Preformato	Metal / Metal / Metal / Metall / Metallo
Y41	10	Preformado / Prefomed/ Préformé / Vorgeformt / Preformato	Metal / Metal / Metal / Metall / Metallo
Y42-Y45	80	Preformado / Prefomed/ Préformé / Vorgeformt / Preformato	Latón / Brass / Latón / Messing / Ottone
Y46	10	ø1,5x6	Latón / Brass / Latón / Messing / Ottone
Y47	2	Preformado / Prefomed/ Préformé / Vorgeformt / Preformato	Metal / Metal / Metal / Metall / Metallo
Y48	2	Preformado / Prefomed/ Préformé / Vorgeformt / Preformato	Metal / Metal / Metal / Metall / Metallo
Y49	2	1x200	Latón / Brass / Latón / Messing / Ottone
Y50	2	Preformado / Prefomed/ Préformé / Vorgeformt / Preformato	Metal / Metal / Metal / Metall / Metallo
Y51	4	ø0,15x100	Hilo marrón / Brown thread / Fil brun /braunes Baumwollfaden / Filo marrone
Y52	6	Preformado / Prefomed/ Préformé / Vorgeformt / Preformato	Latón / Brass / Latón / Messing / Ottone
Y53-Y58	18	Precortado / Precut / Prédécoupé / Vorgeschnitten / Pretagliatto	Tablero / Plywood / Planche / Sperrholz / Tavola
Y59	3	ø3x48	Tilo / Lime wood / Tilleul / Linde / Tiglio
Y60	18	Precortado / Precut / Prédécoupé / Vorgeschnitten / Pretagliatto	Tablero / Plywood / Planche / Sperrholz / Tavola
Y61	9	Preformado / Prefomed/ Préformé / Vorgeformt / Preformato	Metal / Metal / Metal / Metall / Metallo
Y62-Y68	18	Preformado / Prefomed/ Préformé / Vorgeformt / Preformato	Latón / Brass / Latón / Messing / Ottone
Y69	6	Preformado / Prefomed/ Préformé / Vorgeformt / Preformato	Metal / Metal / Metal / Metall / Metallo
Y70	4	Preformado / Prefomed/ Préformé / Vorgeformt / Preformato	Metal / Metal / Metal / Metall / Metallo
Y71	12	Preformado / Prefomed/ Préformé / Vorgeformt / Preformato	Metal / Metal / Metal / Metall / Metallo
Y72	2	Preformado / Prefomed/ Préformé / Vorgeformt / Preformato	Metal / Metal / Metal / Metall / Metallo
Y73-Y75	6	Precortado / Precut / Prédécoupé / Vorgeschnitten / Pretagliatto	Tablero / Plywood / Planche / Sperrholz / Tavola
Y76	2	Preformado / Prefomed/ Préformé / Vorgeformt / Preformato	Latón / Brass / Latón / Messing / Ottone
Y77	2	ø1x119	Latón / Brass / Latón / Messing / Ottone
Y78	22	ø1x14	Latón / Brass / Latón / Messing / Ottone
Y79	2	ø1x35	Latón / Brass / Latón / Messing / Ottone
Y80	9	Preformado / Prefomed/ Préformé / Vorgeformt / Preformato	Latón / Brass / Latón / Messing / Ottone
Y81	18	ø1x17	Latón / Brass / Latón / Messing / Ottone
Y82	3	Preformado / Prefomed/ Préformé / Vorgeformt / Preformato	Latón / Brass / Latón / Messing / Ottone
Y83	6	Preformado / Prefomed/ Préformé / Vorgeformt / Preformato	Latón / Brass / Latón / Messing / Ottone
Z1	3	Preformado / Prefomed/ Préformé / Vorgeformt / Preformato	Madera / Wood / Bois / Holz / Legno
Z2	1	Preformado / Prefomed/ Préformé / Vorgeformt / Preformato	Metal / Metal / Metal / Metall / Metallo
Z3	1	Preformado / Prefomed/ Préformé / Vorgeformt / Preformato	Metal / Metal / Metal / Metall / Metallo
Z4	1	Preformado / Prefomed/ Préformé / Vorgeformt / Preformato	Metal / Metal / Metal / Metall / Metallo
Z5	1	Preformado / Prefomed/ Préformé / Vorgeformt / Preformato	Latón / Brass / Latón / Messing / Ottone
Z6	1	Preformado / Prefomed/ Préformé / Vorgeformt / Preformato	Latón / Brass / Latón / Messing / Ottone
Z7-Z9	3	Preformado / Prefomed/ Préformé / Vorgeformt / Preformato	Latón / Brass / Latón / Messing / Ottone
Z10	1	Preformado / Prefomed/ Préformé / Vorgeformt / Preformato	Latón / Brass / Latón / Messing / Ottone
Z11	1	Precortado / Precut / Prédécoupé / Vorgeschnitten / Pretagliatto	Tablero / Plywood / Planche / Sperrholz / Tavola
Z12	1	ø1x5	Latón / Brass / Latón / Messing / Ottone
Z13	1	ø1x4	Latón / Brass / Latón / Messing / Ottone
Z14	1	Preformado / Prefomed/ Préformé / Vorgeformt / Preformato	Latón / Brass / Latón / Messing / Ottone
Z15	1	Preformado / Prefomed/ Préformé / Vorgeformt / Preformato	Latón / Brass / Latón / Messing / Ottone
Z16	1	Precortado / Precut / Prédécoupé / Vorgeschnitten / Pretagliatto	Tablero / Plywood / Planche / Sperrholz / Tavola
Z17	1	Preformado / Prefomed/ Préformé / Vorgeformt / Preformato	Latón / Brass / Latón / Messing / Ottone
Z18	1	ø1,5x65	Latón / Brass / Latón / Messing / Ottone
Z19	1	Preformado / Prefomed/ Préformé / Vorgeformt / Preformato	Latón / Brass / Latón / Messing / Ottone
Z20	1	ø1x70	Latón / Brass / Latón / Messing / Ottone
Z21	1	ø1x54	Latón / Brass / Latón / Messing / Ottone
Z22	3	ø1x15	Latón / Brass / Latón / Messing / Ottone
Z23-Z24	3	Preformado / Prefomed/ Préformé / Vorgeformt / Preformato	Vinilo / Vinyl / Vinyle / Vinyl / Vinile
Z25	2	ø0,15x300	Hilo marrón / Brown thread / Fil brun /braunes Baumwollfaden / Filo marrone
Z26	2	ø0,15x400	Hilo marrón / Brown thread / Fil brun /braunes Baumwollfaden / Filo marrone

<i>Lista de piezas / Parts List / Liste des pièces / Teileliste / Elenco delle parti</i>			
<i>Nº/No./ Nº / Nr. No</i>	<i>Cantidad / Quantity / Quantité / Menge / Quantità</i>	<i>Medidas / Measurements / Dimensions /Maße / Misure</i>	<i>Material / Material / Matériau / Material / Materiale</i>
Z27	6	ø0,15x450	Hilo marrón / Brown thread / Fil brun /braunes Baumwollfaden / Filo marrone
Z28	4	ø0,15x425	Hilo marrón / Brown thread / Fil brun /braunes Baumwollfaden / Filo marrone
Z29	2	ø0,15x450	Hilo marrón / Brown thread / Fil brun /braunes Baumwollfaden / Filo marrone
Z30	1	Preformado / Preformed/ Préformé / Vorgeformt / Preformato	Latón / Brass / Latón / Messing / Ottone
Z31-Z32	2	Precortado / Precut / Prédécoupé / Vorgeschnitten / Pretagliatto	Tablero / Plywood / Planche / Sperrholz / Tavola
Z33	2	Precortado / Precut / Prédécoupé / Vorgeschnitten / Pretagliatto	Tablero / Plywood / Planche / Sperrholz / Tavola
Z34	1	Preformado / Preformed/ Préformé / Vorgeformt / Preformato	Metal / Metal / Metal / Metall / Metallo
Z35	4	ø1x5	Latón / Brass / Latón / Messing / Ottone
Z36	4	Preformado / Preformed/ Préformé / Vorgeformt / Preformato	Latón / Brass / Latón / Messing / Ottone
A	1500	Preformado / Preformed/ Préformé / Vorgeformt / Preformato	Metal / Metal / Metal / Metall / Metallo

USS MISSOURI

PL-01

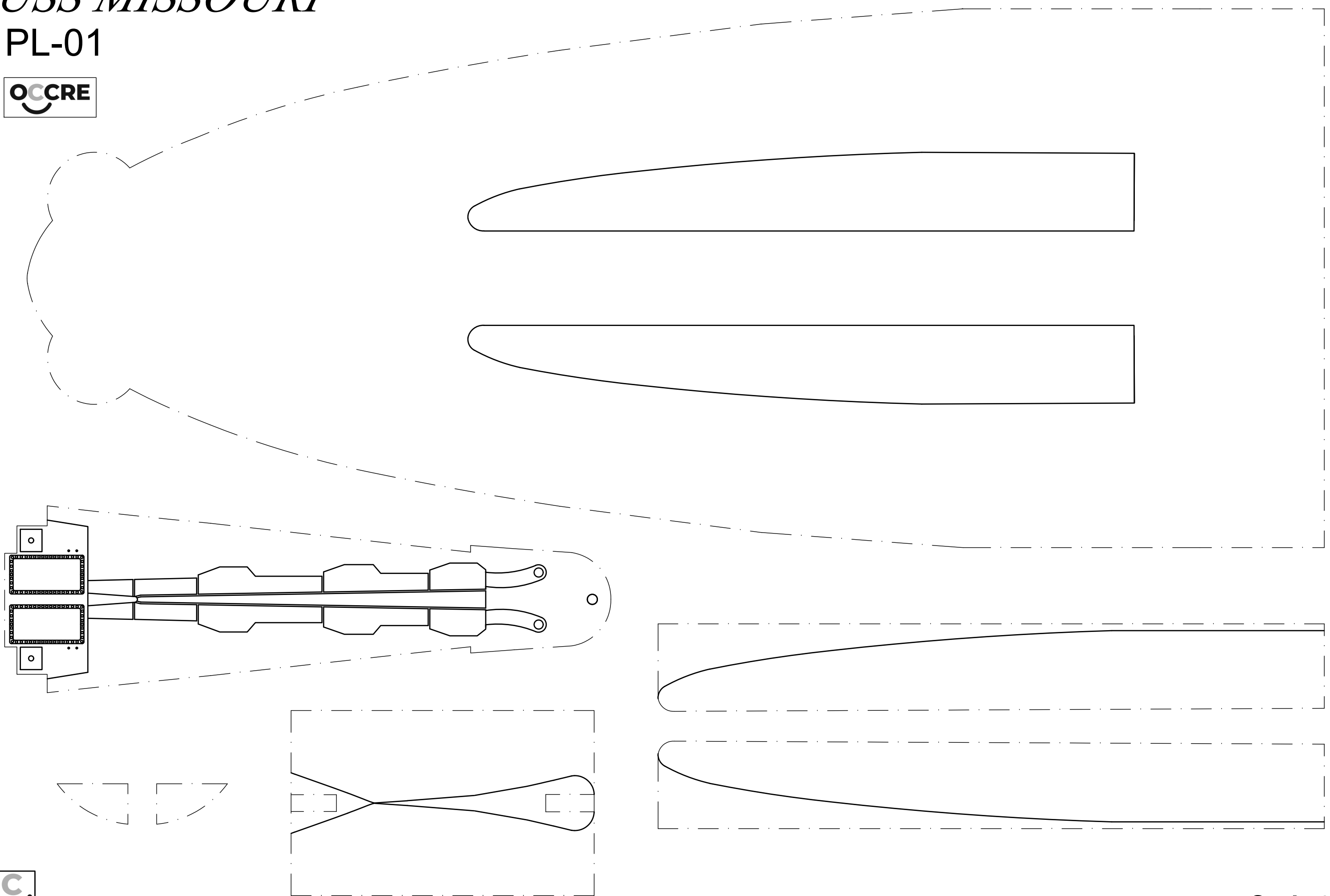

Scale 1/1

USS MISSOURI

PL-02

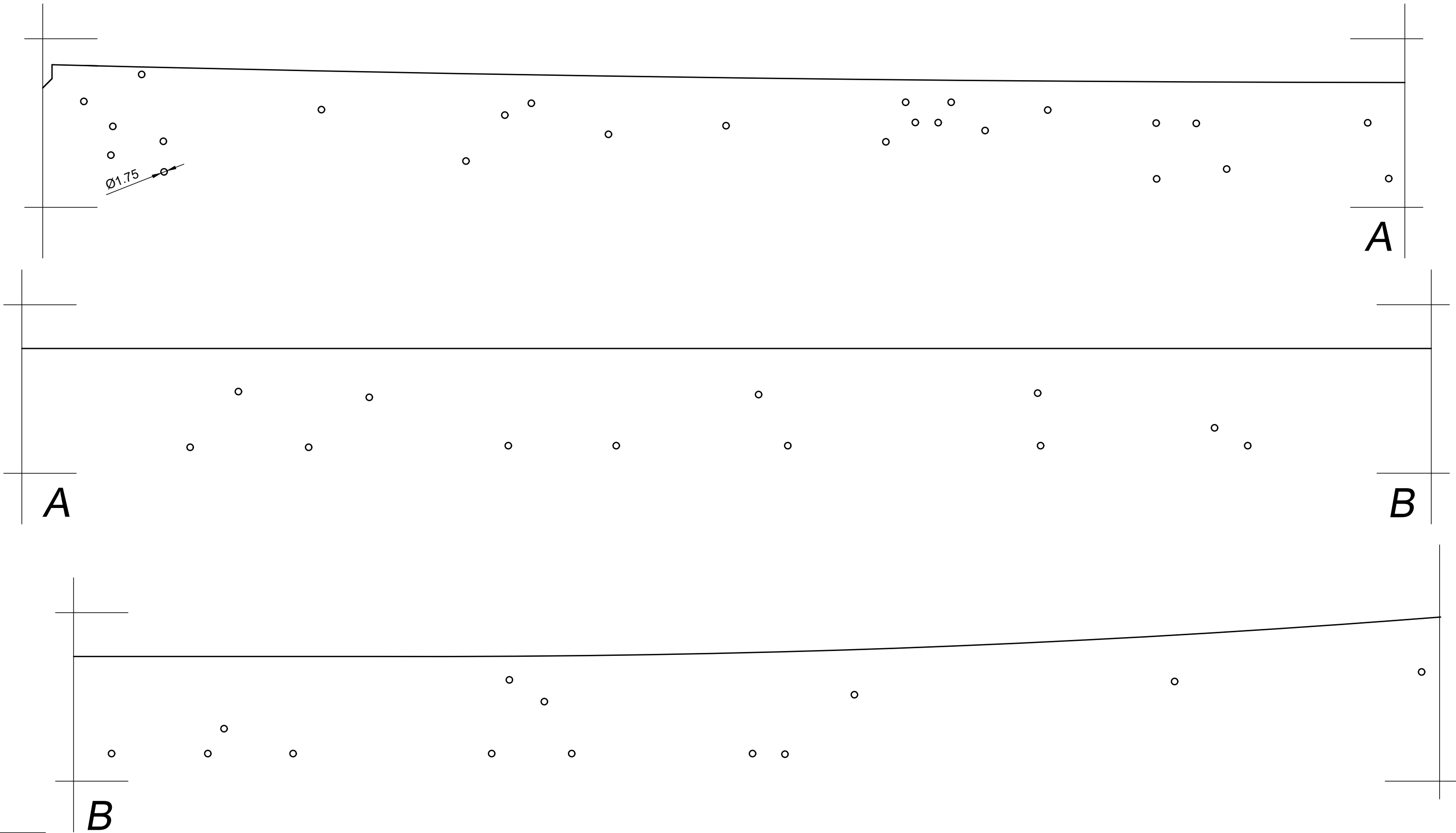

Scale 1/1

USS MISSOURI

PL-03

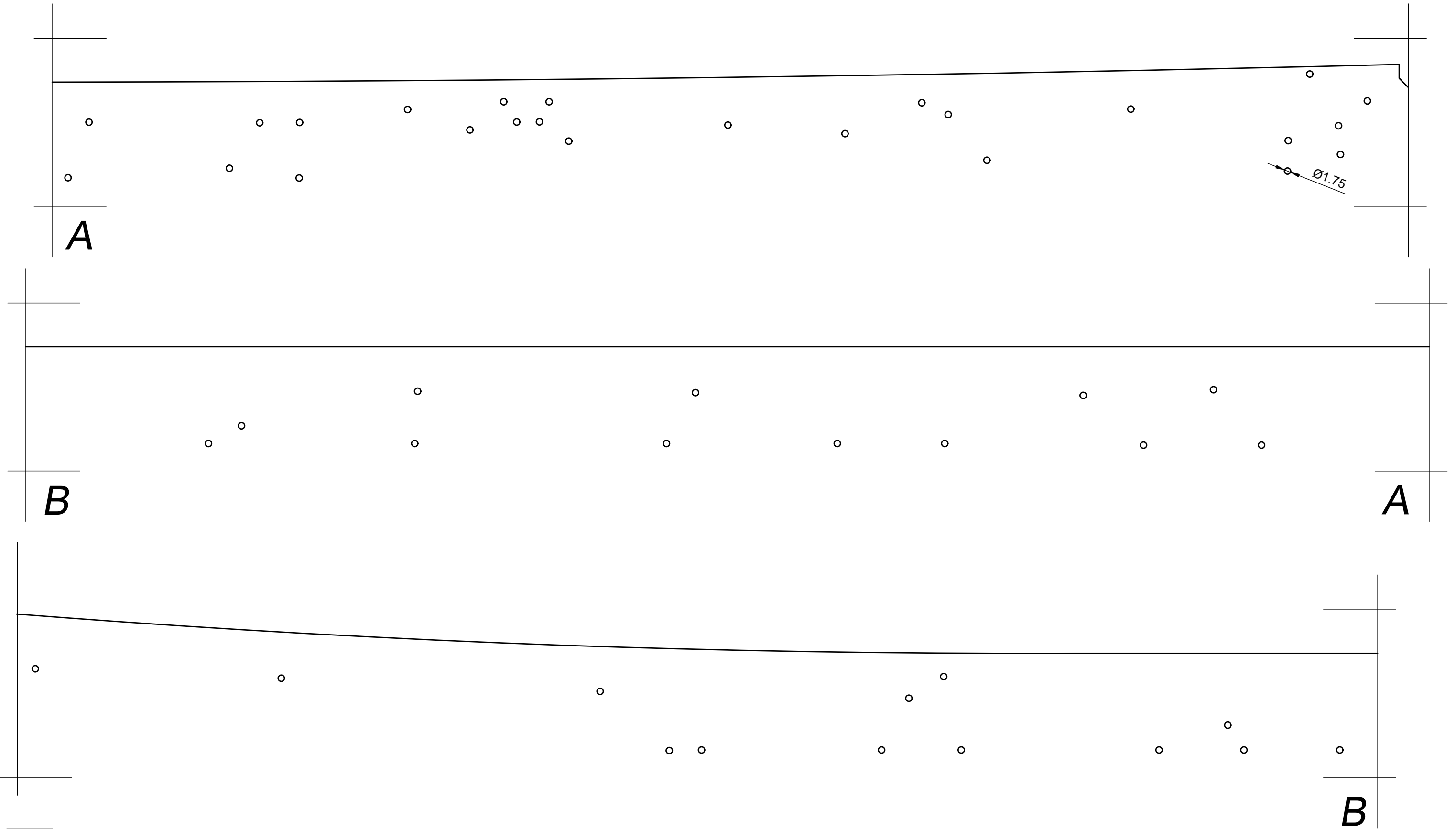

Scale 1/1

USS MISSOURI

PL-04 A

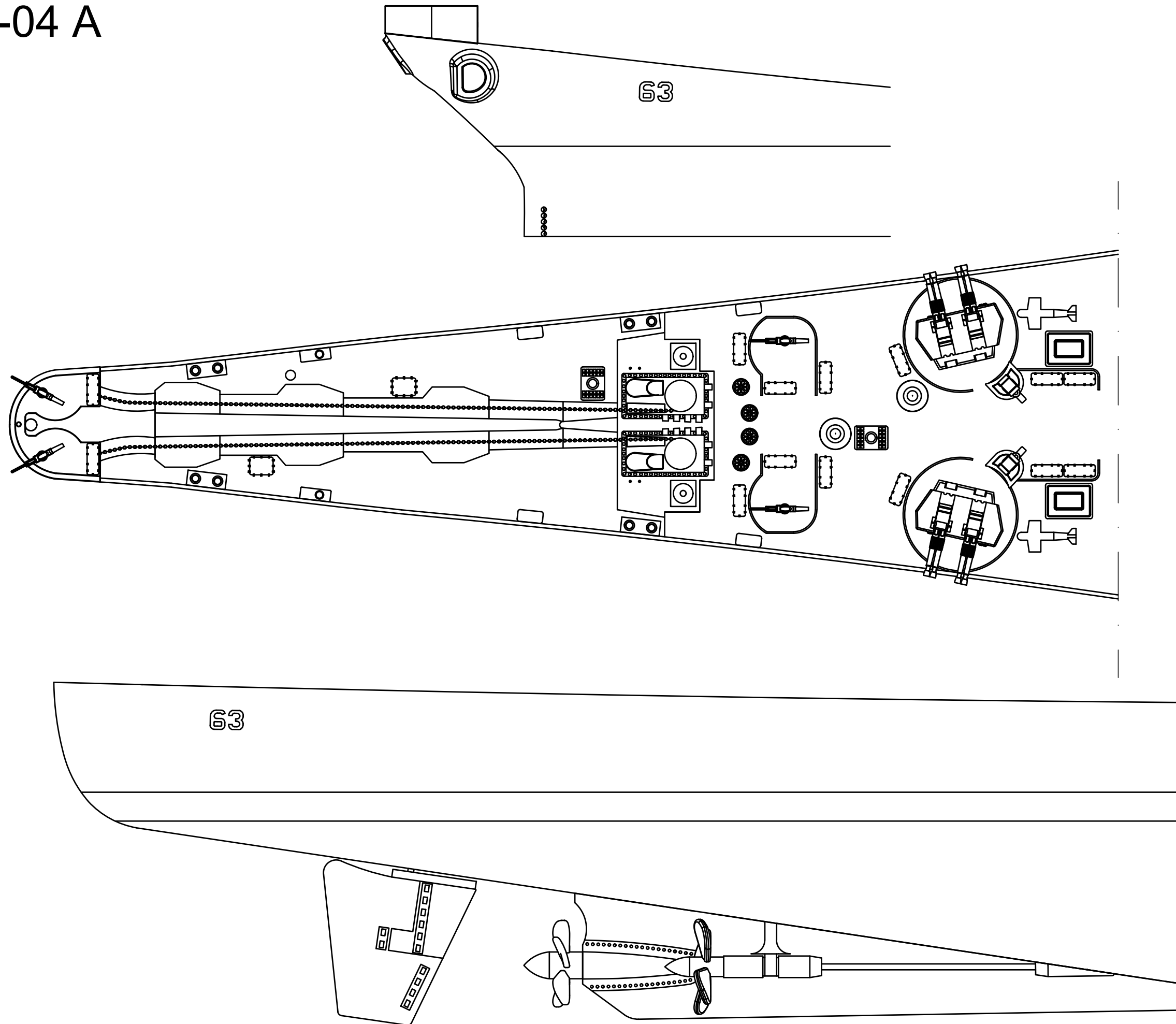

Scale 1/1

USS MISSOURI

PL-04 B

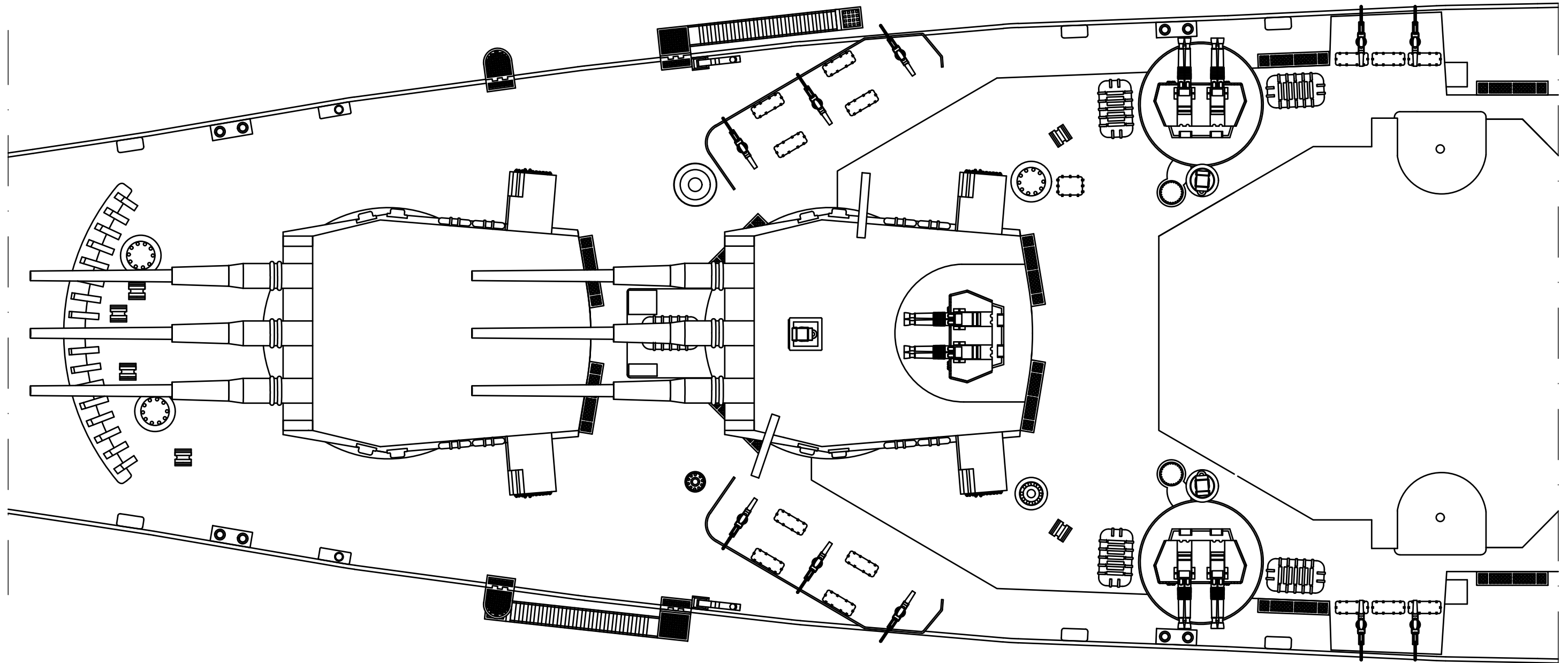

USS MISSOURI

PL-04 C

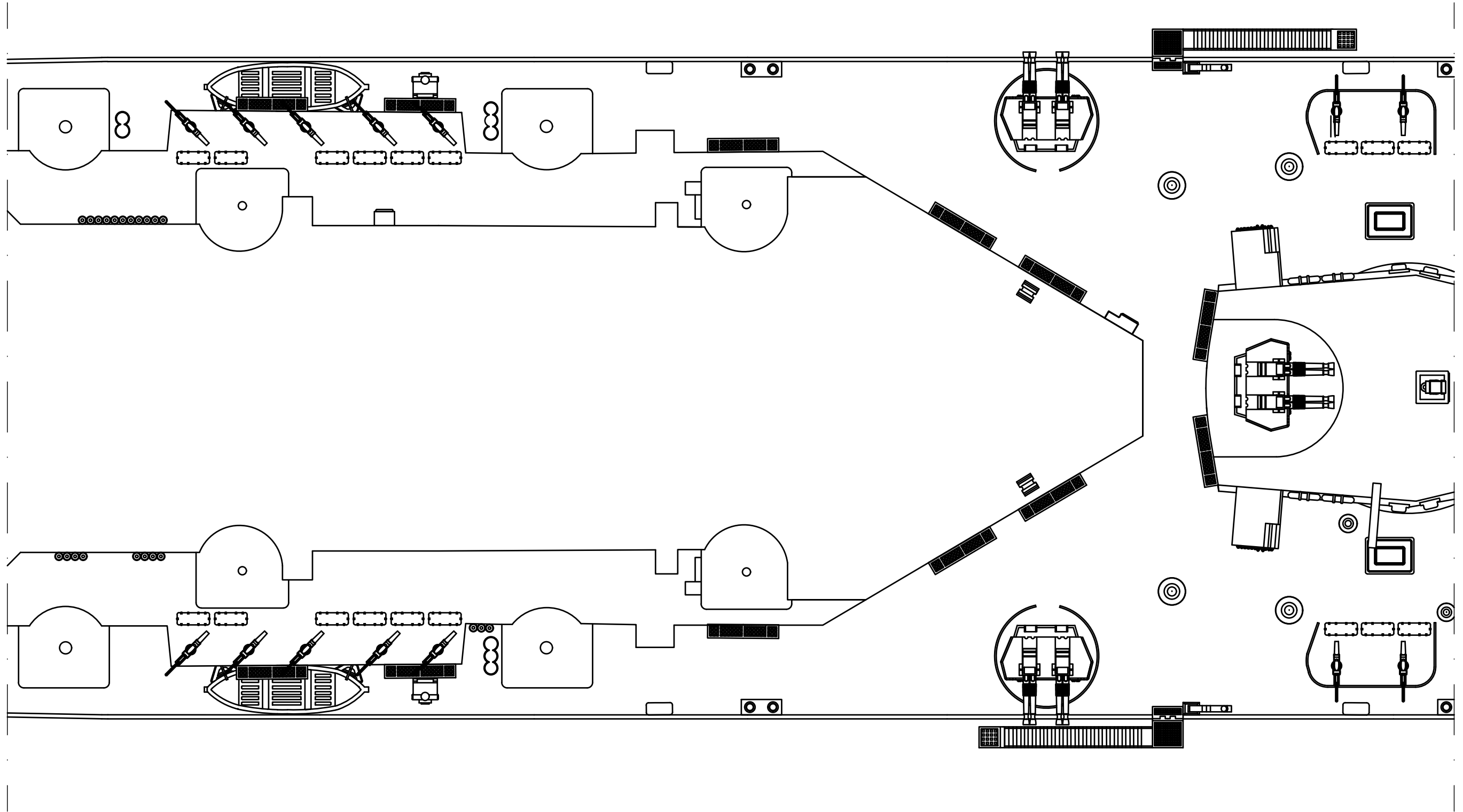

Scale 1/1

USS MISSOURI

PL-04 D

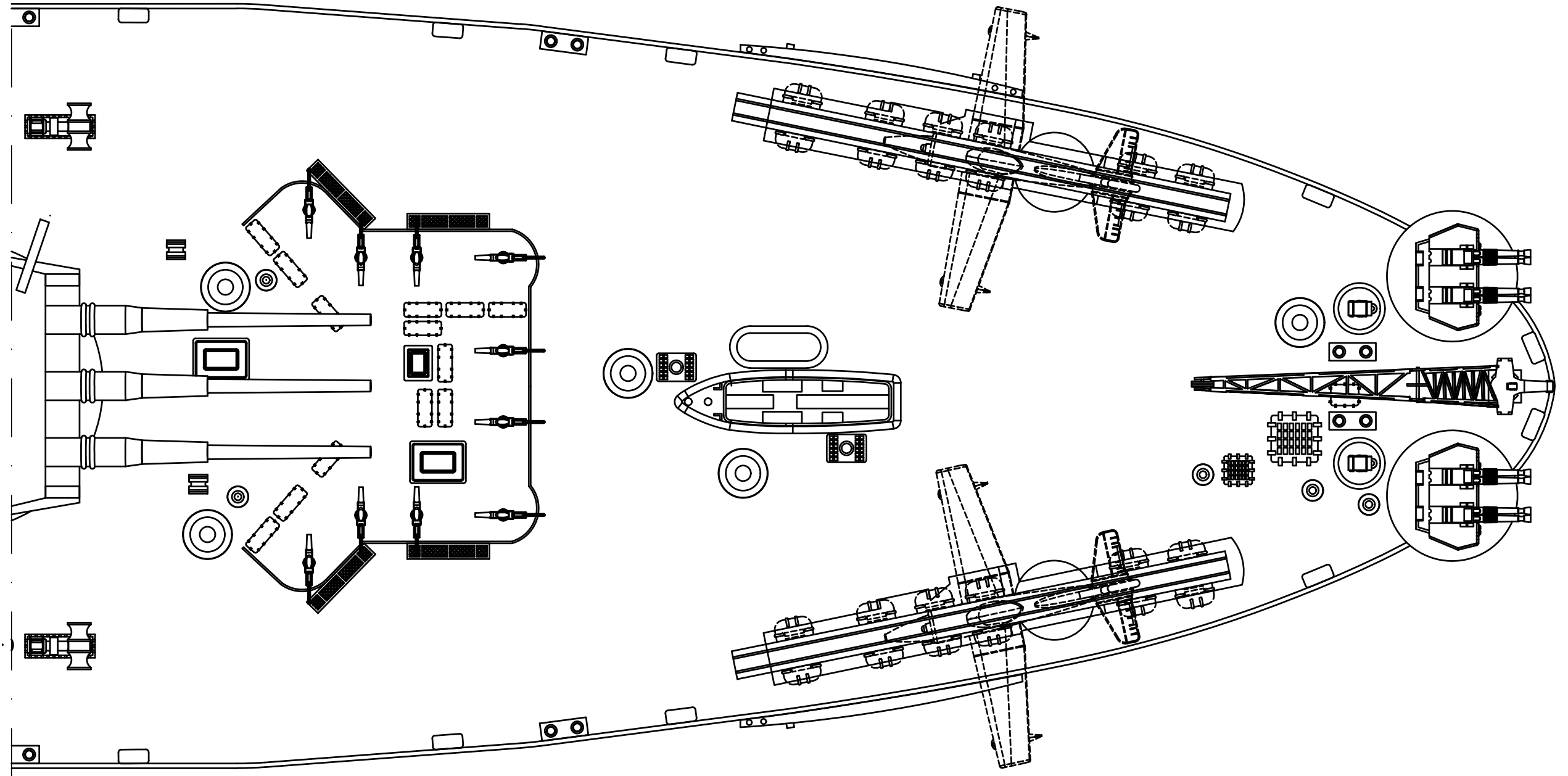

Scale 1/1



Accede a vídeos tutoriales fotografiando los códigos QR.
Access tutorial videos photographing QR codes.
Accédez aux didacticiels vidéo photographiant les codes QR.
Greifen Sie auf Video-Tutorials zu, die QR-Code fotografieren.
Accedi ai video tutorial fotografando i codici QR.
Доступ к видеоурокам фотографирования QR-кодов.

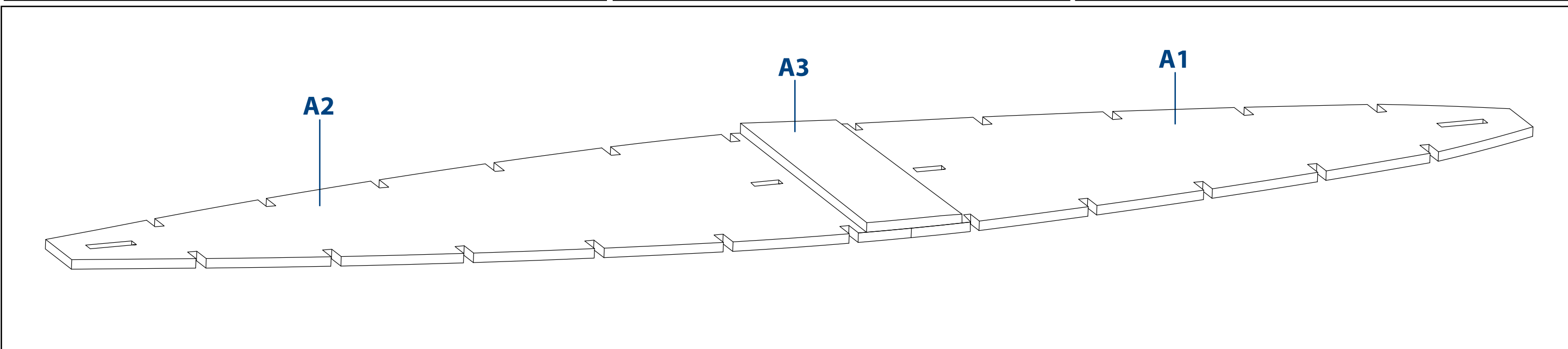
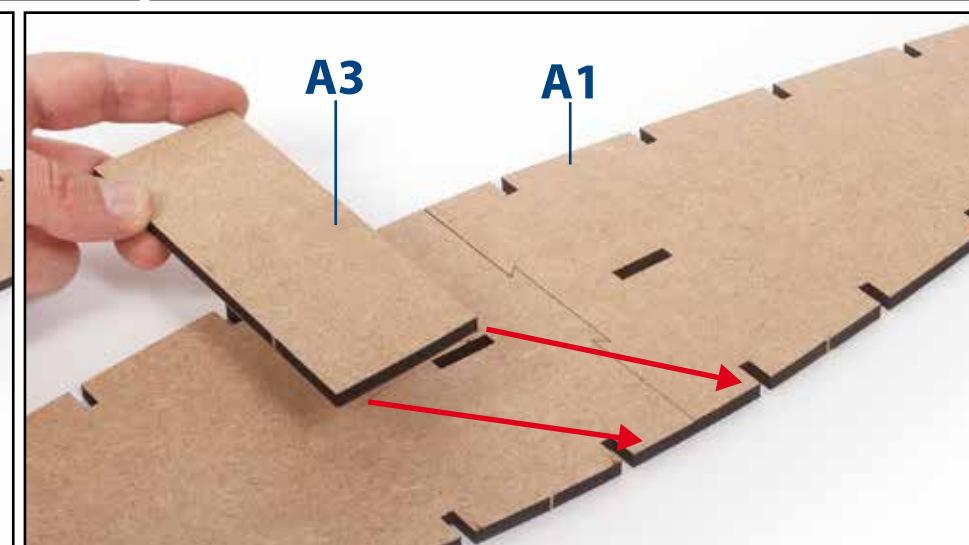
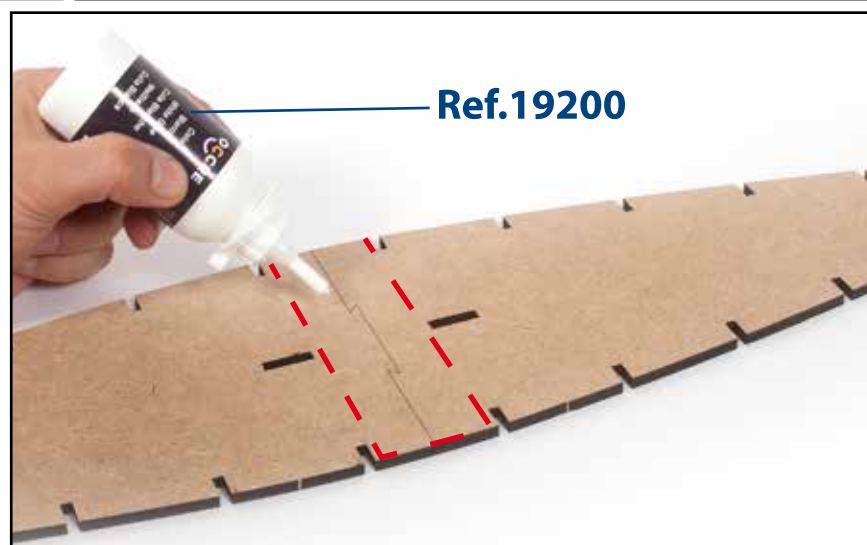
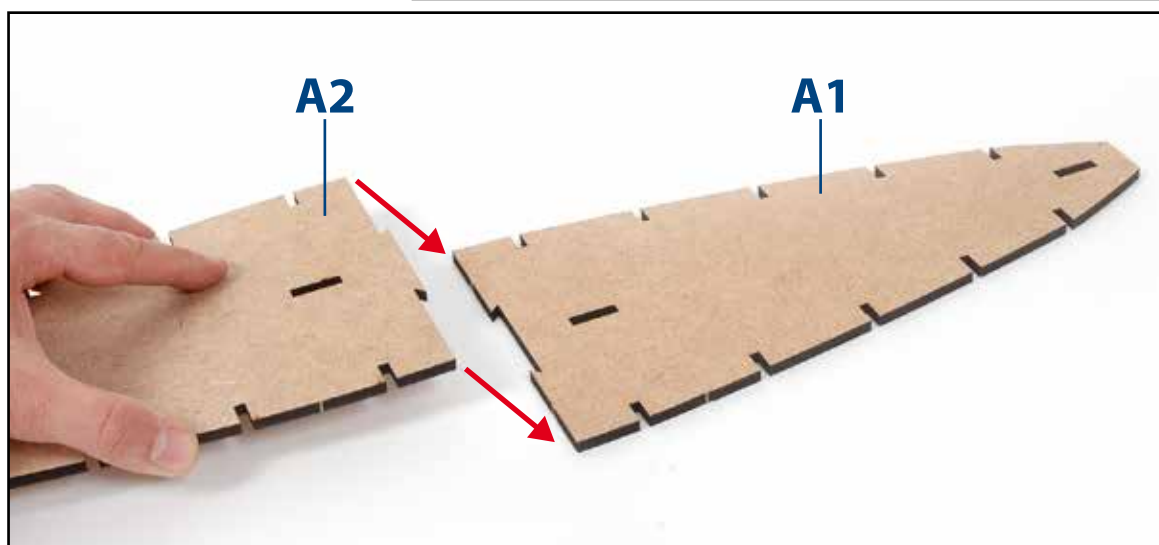
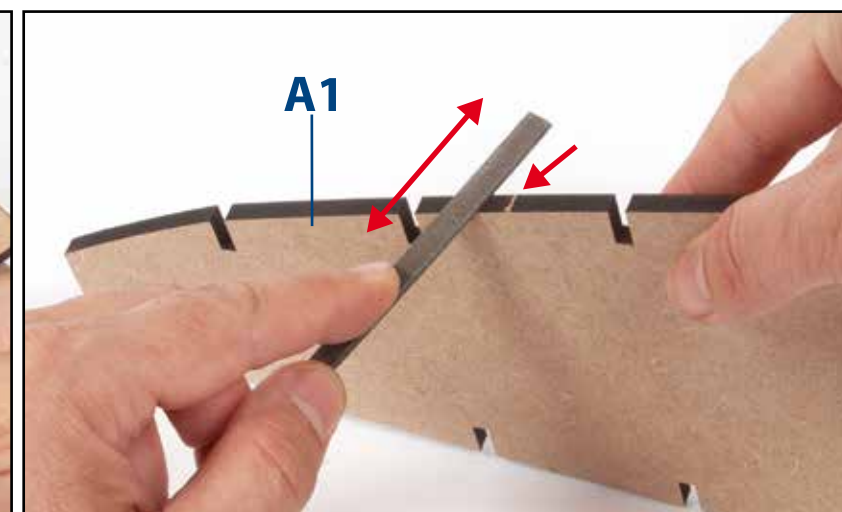
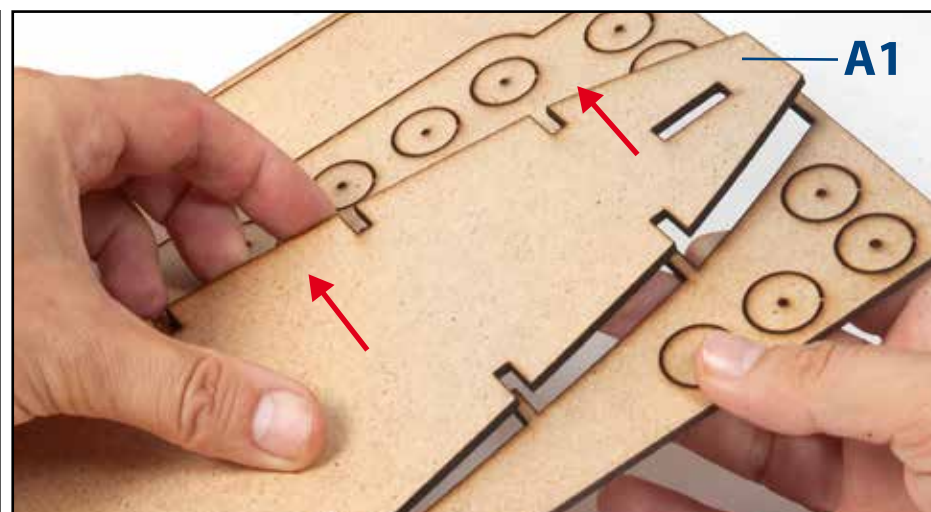
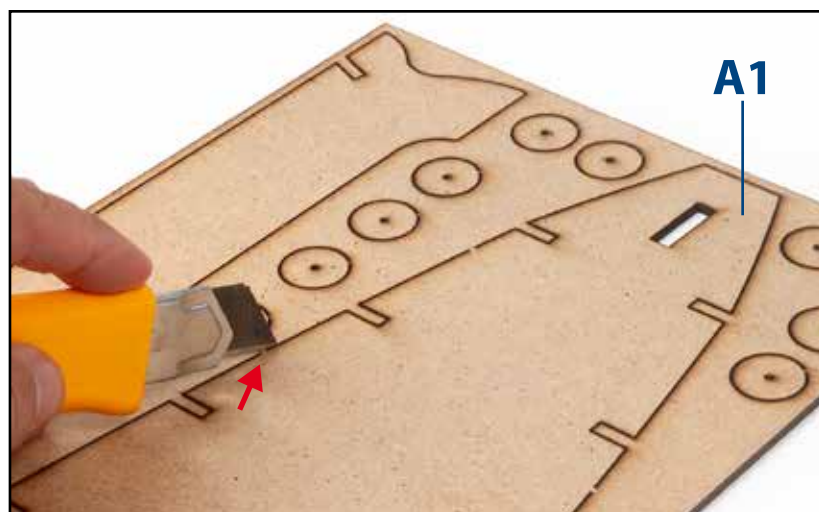

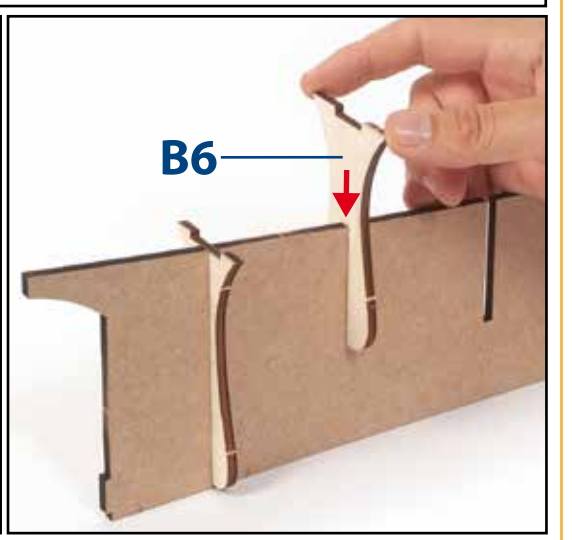
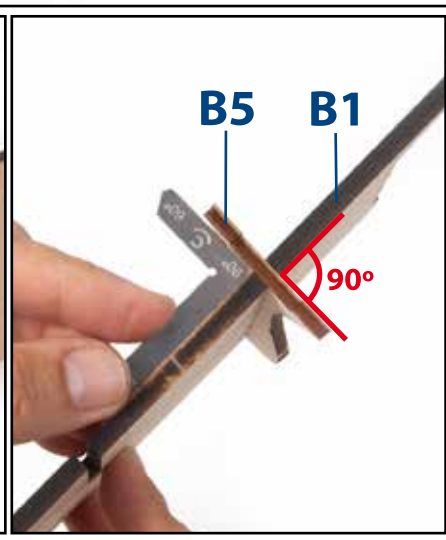
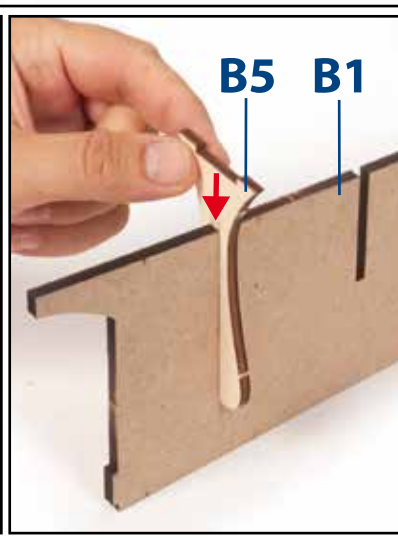
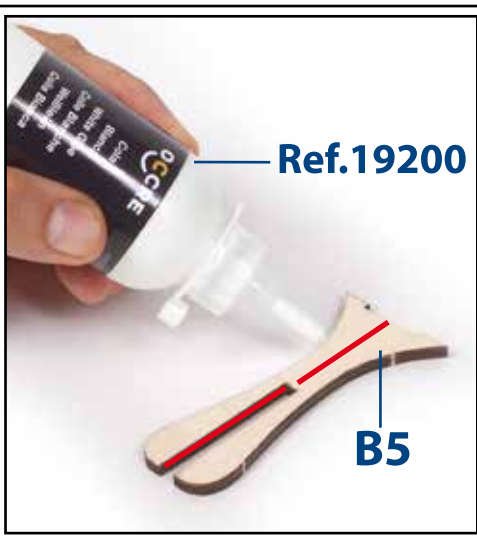
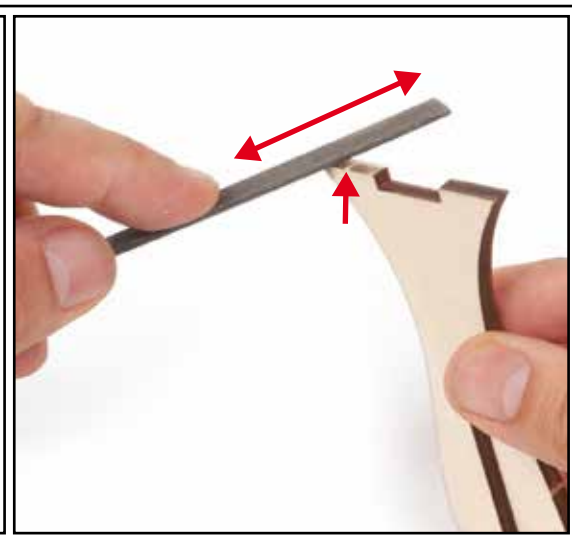
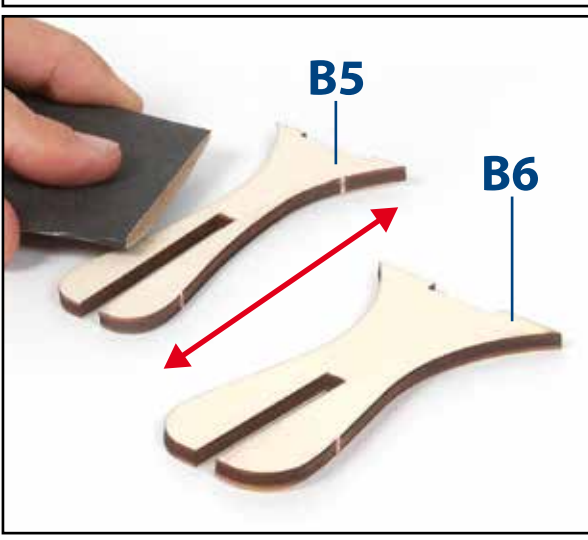
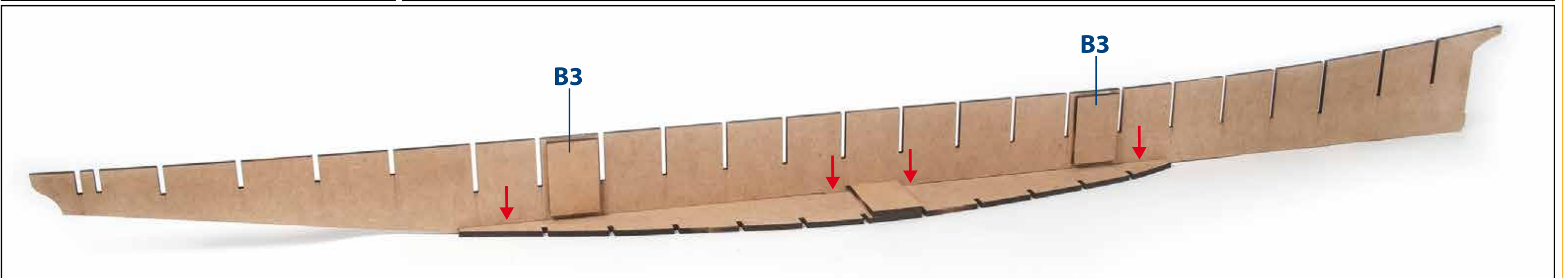
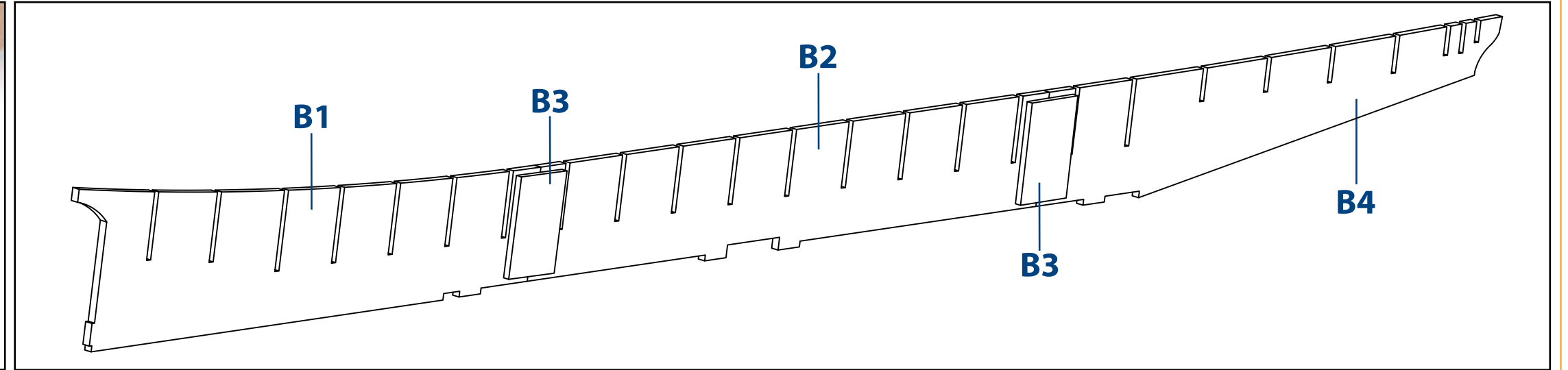
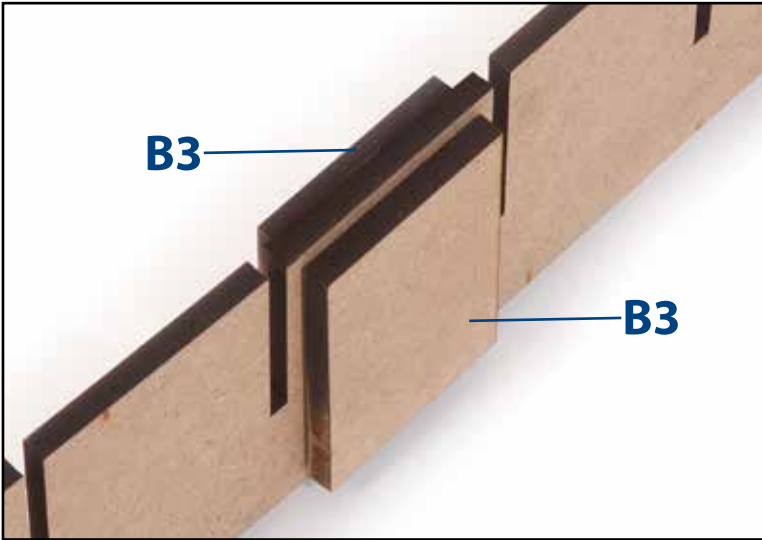
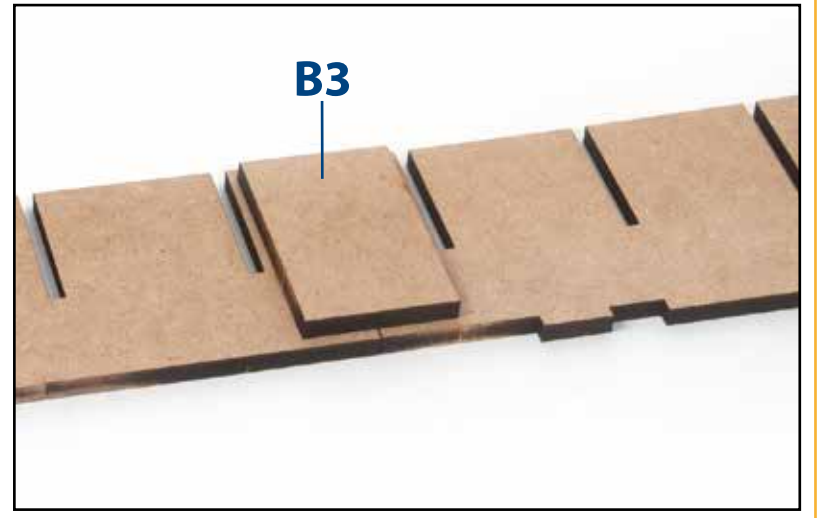
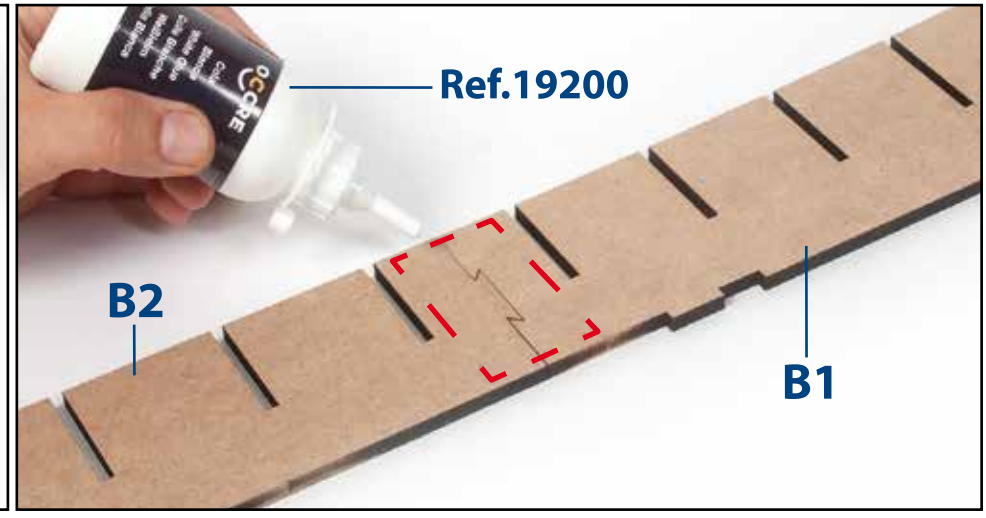
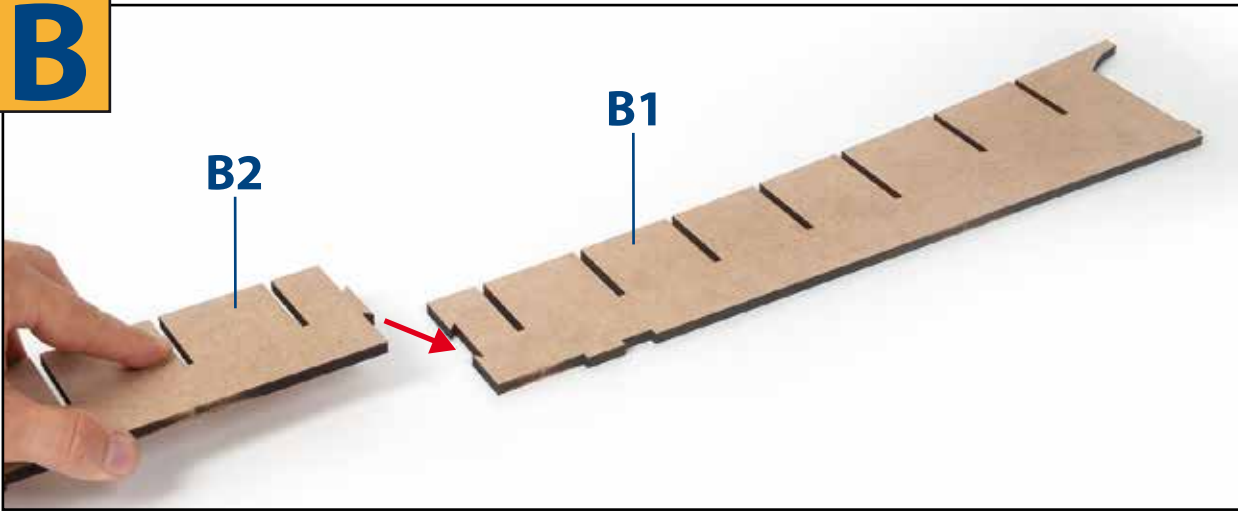
B

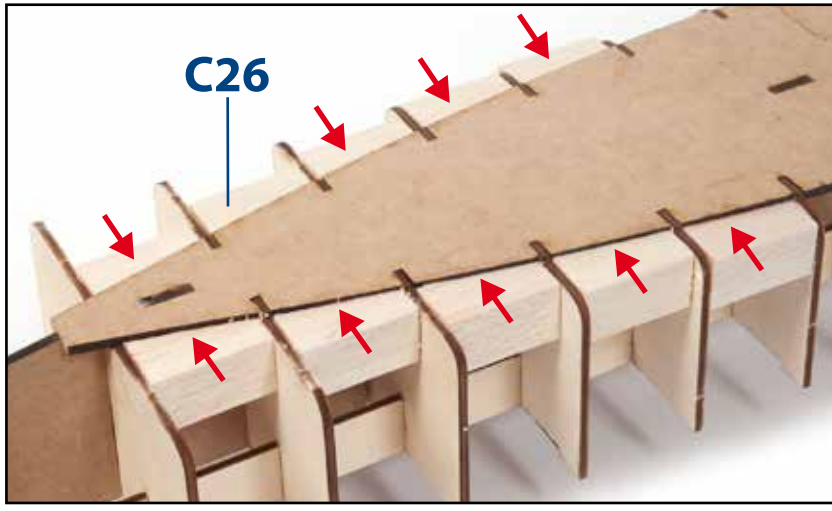
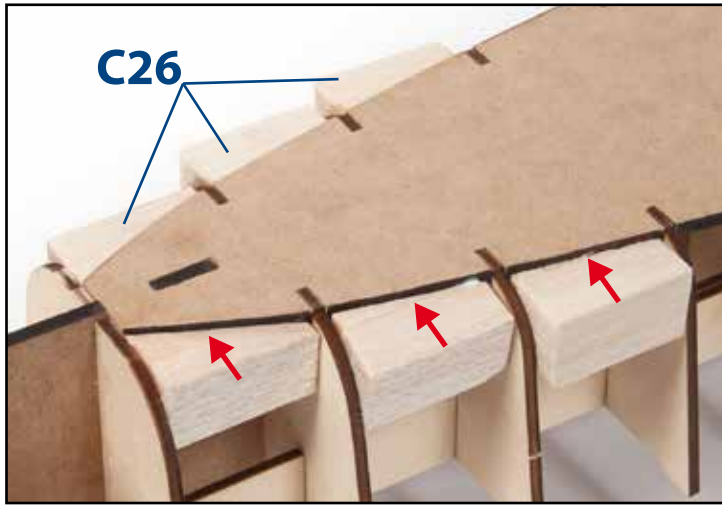
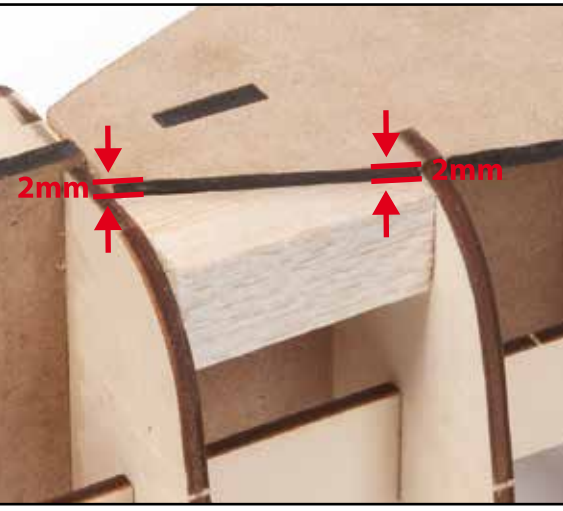
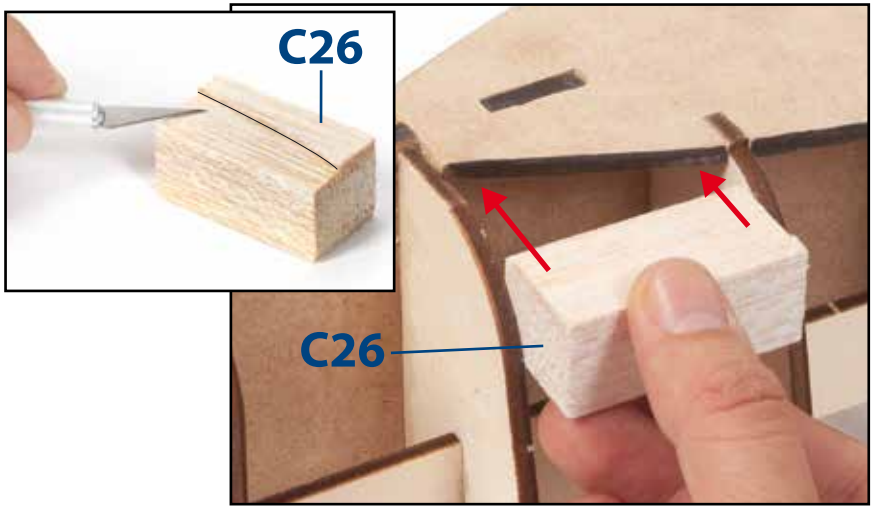
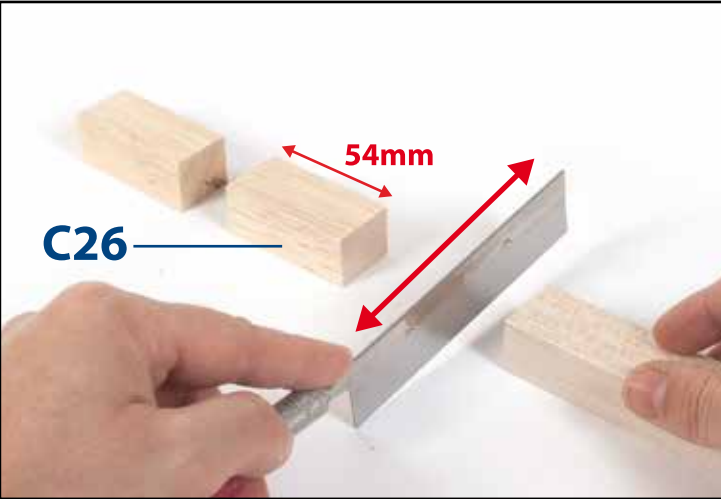
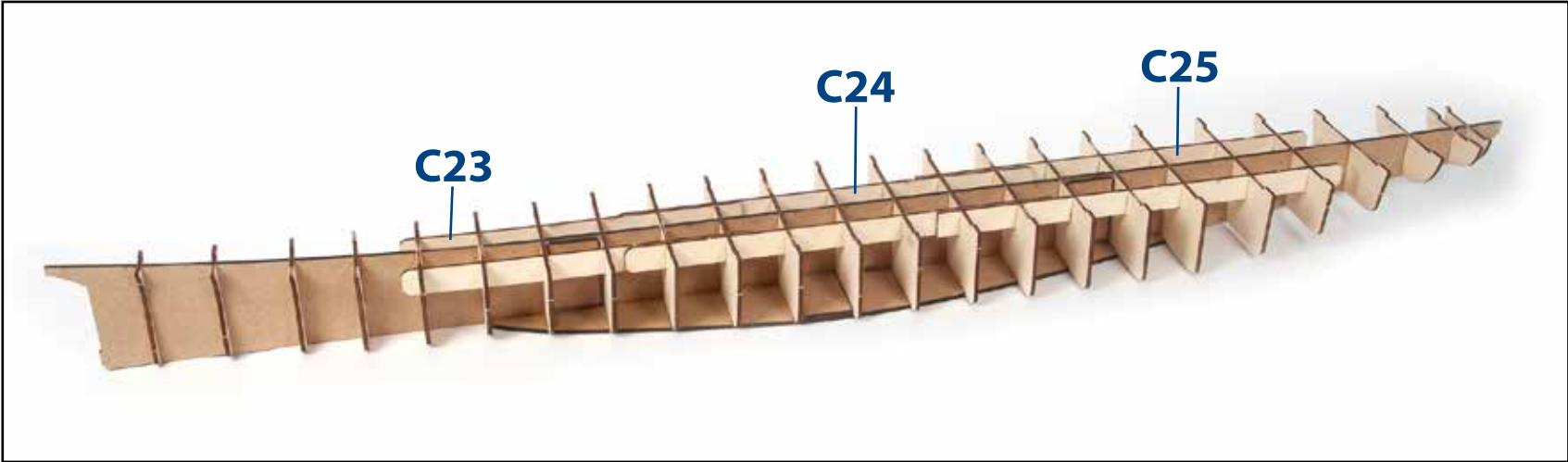
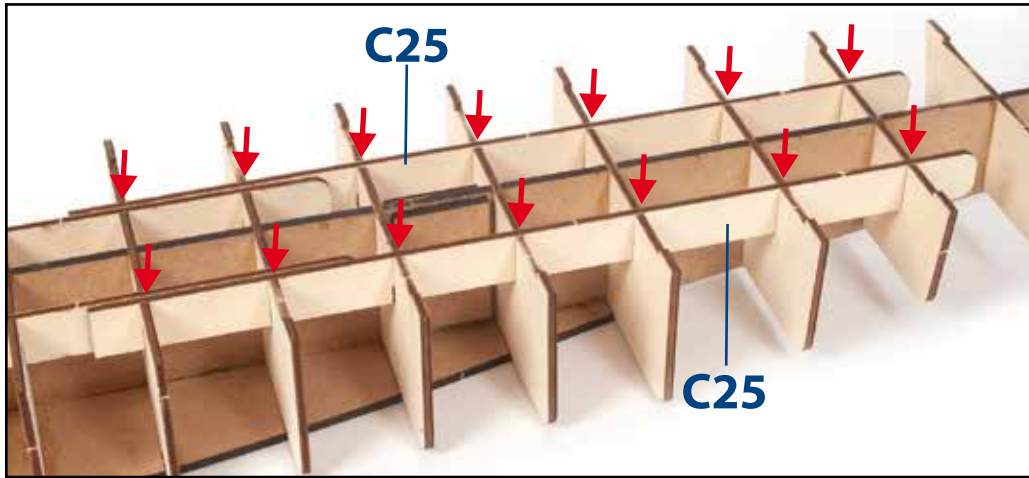
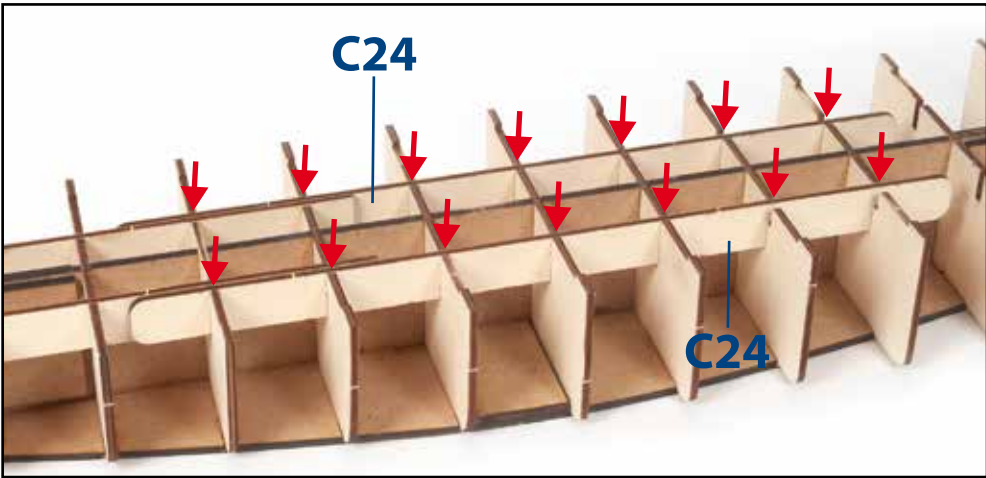
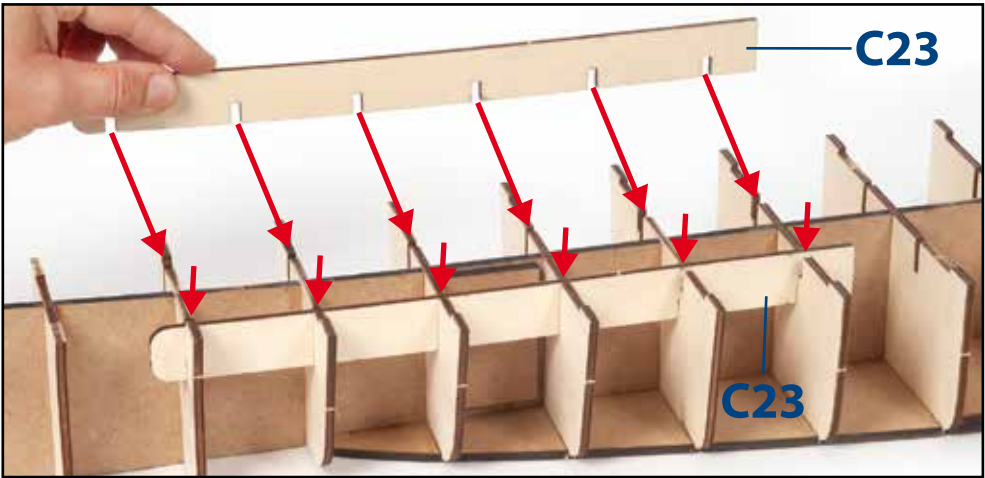
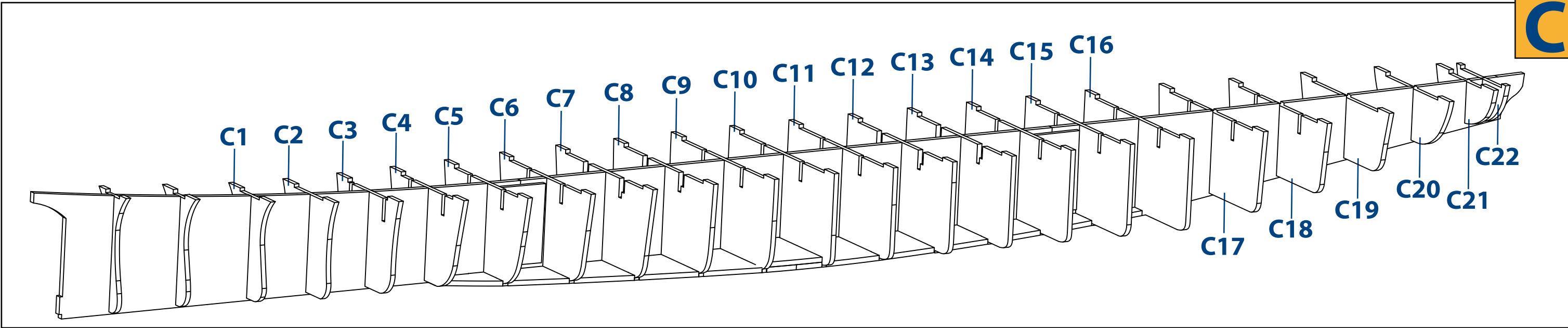

D

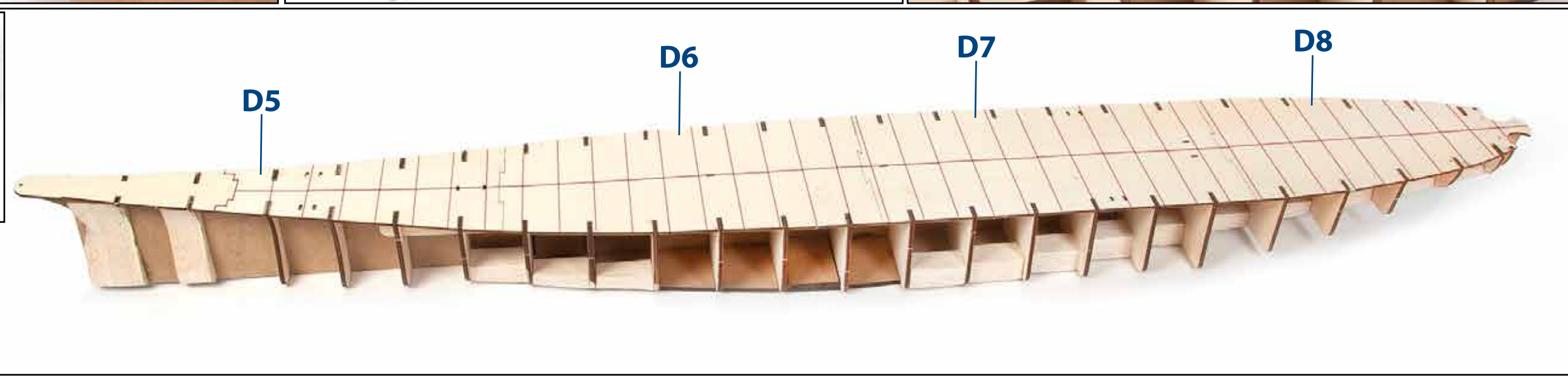
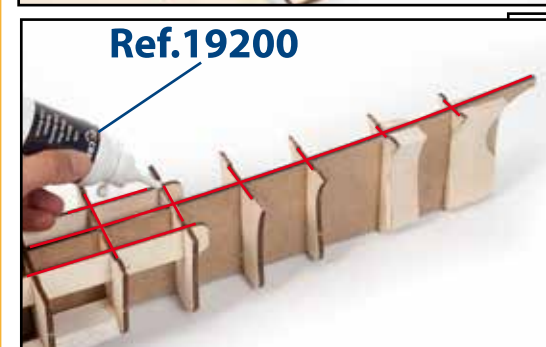
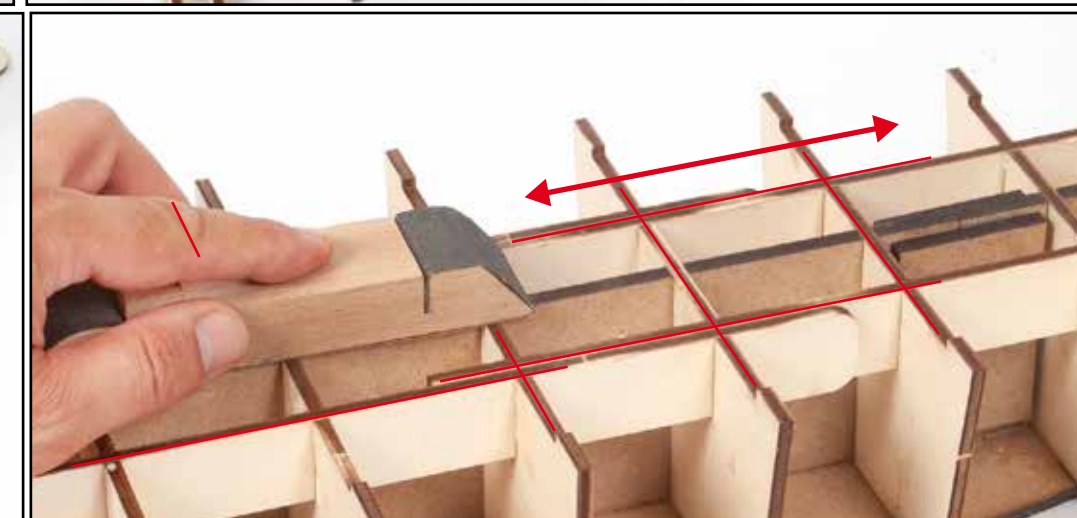
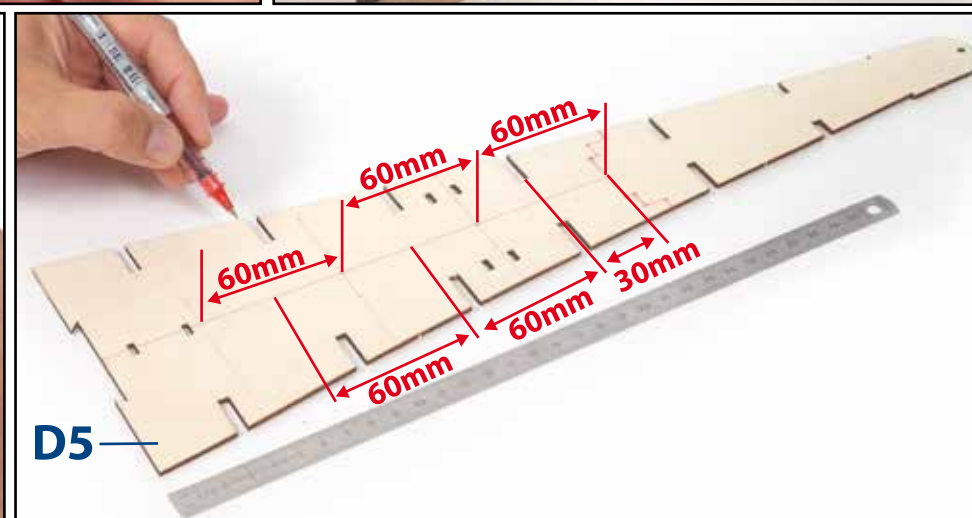
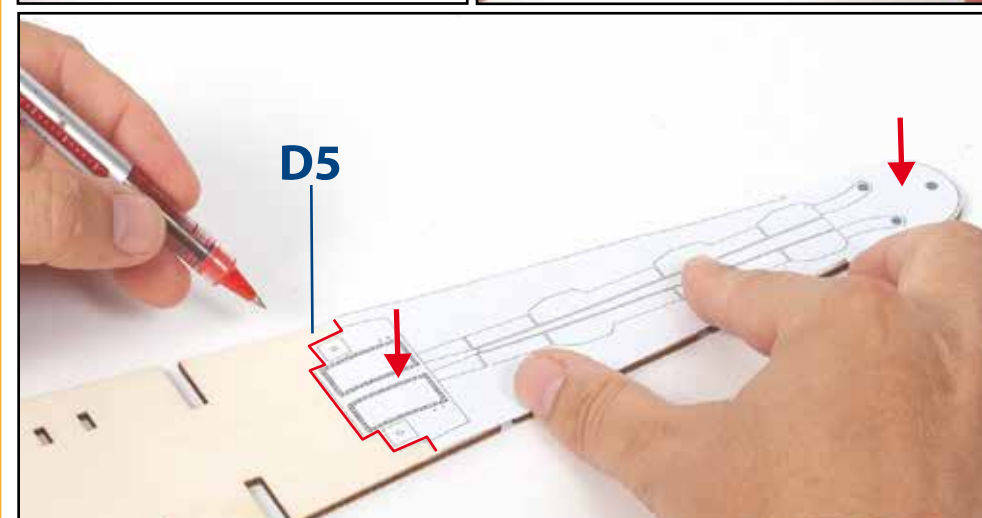
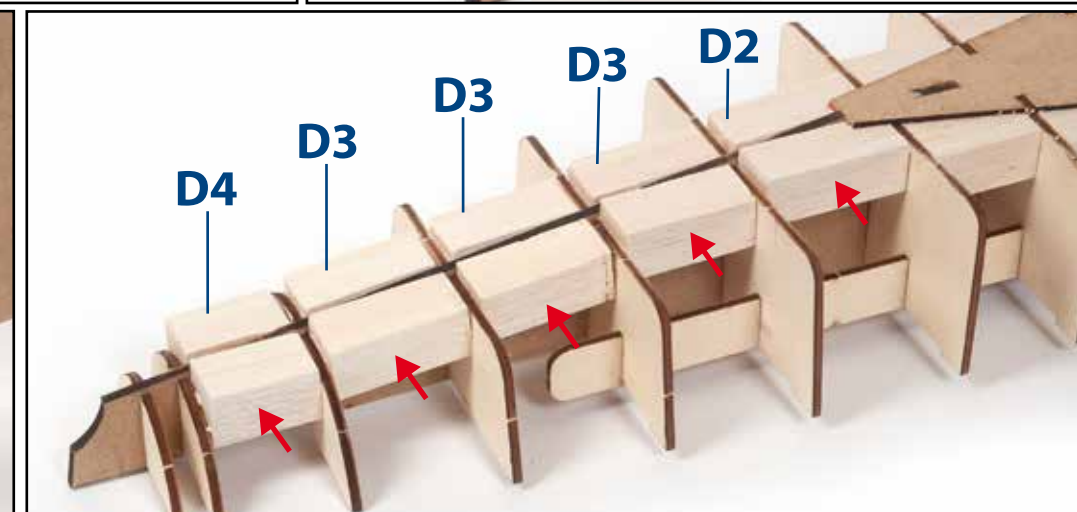
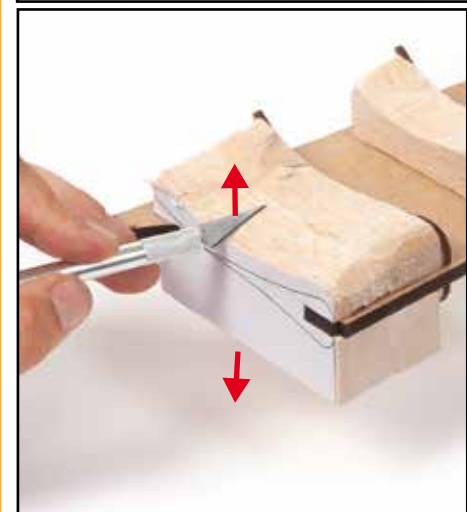
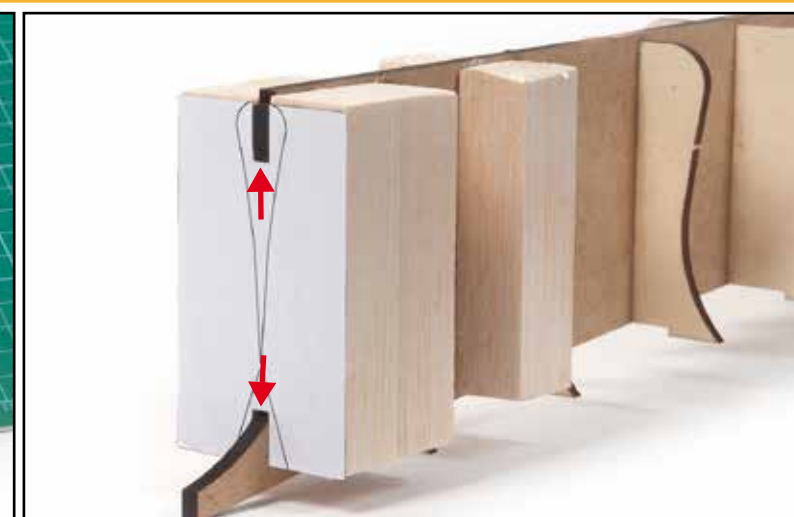
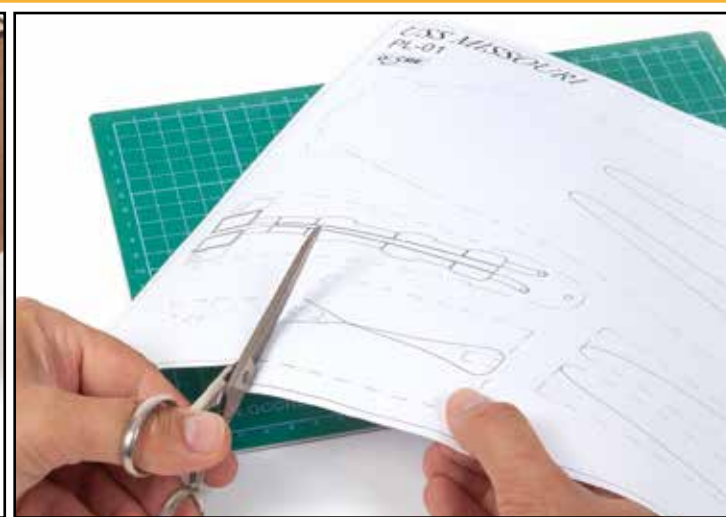
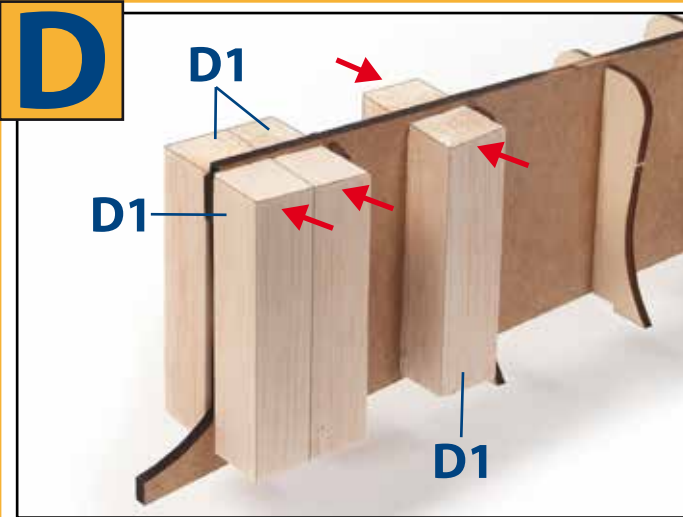

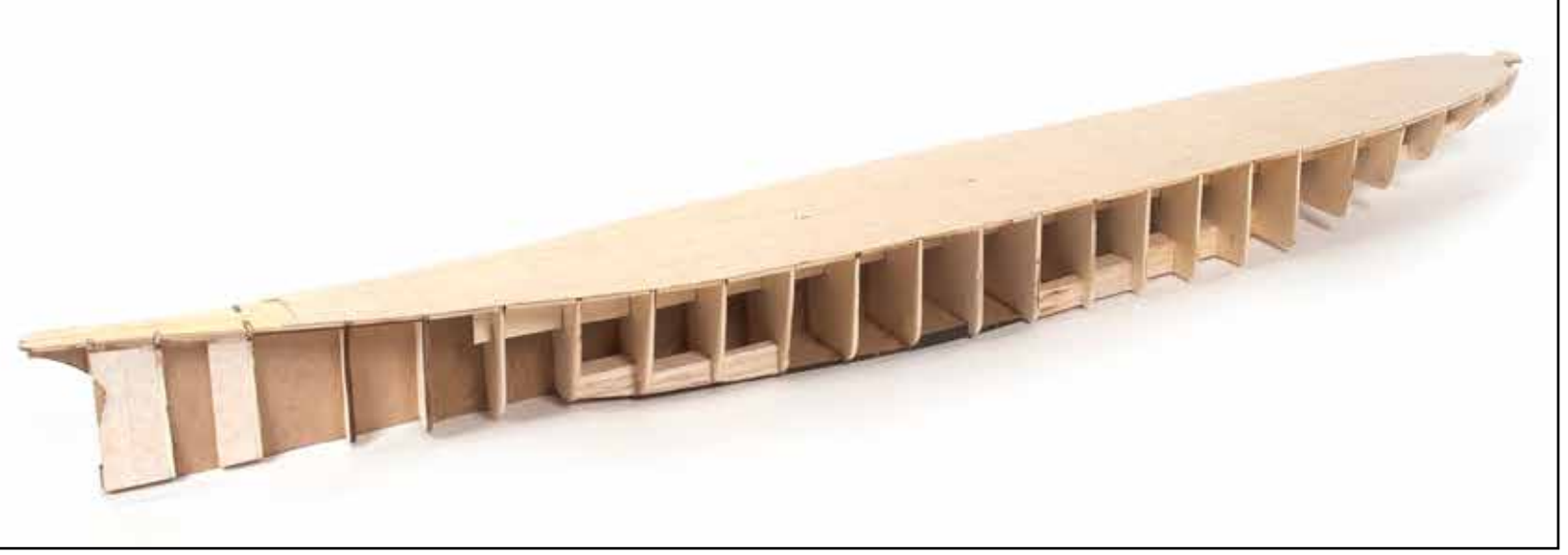
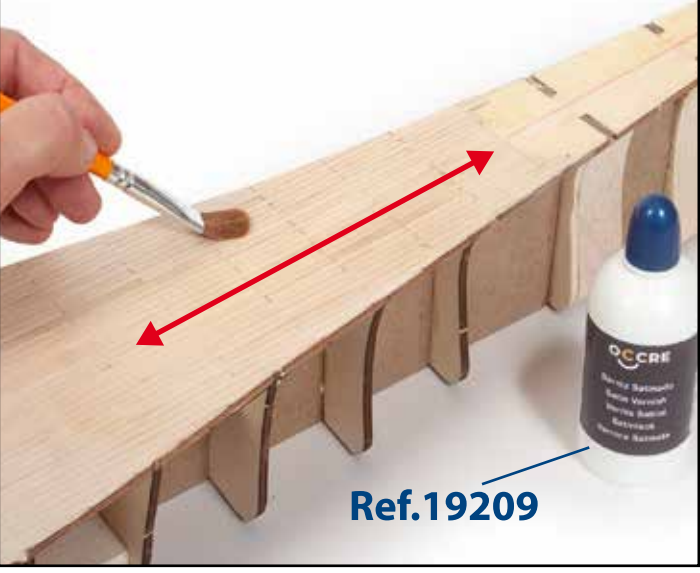
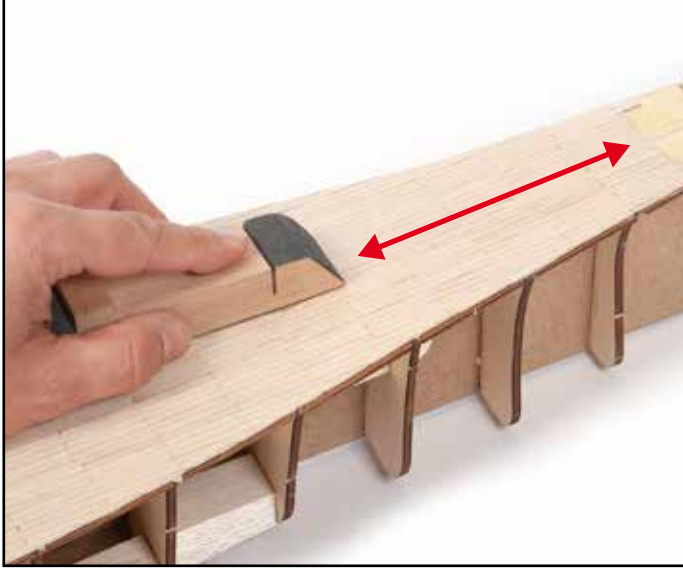
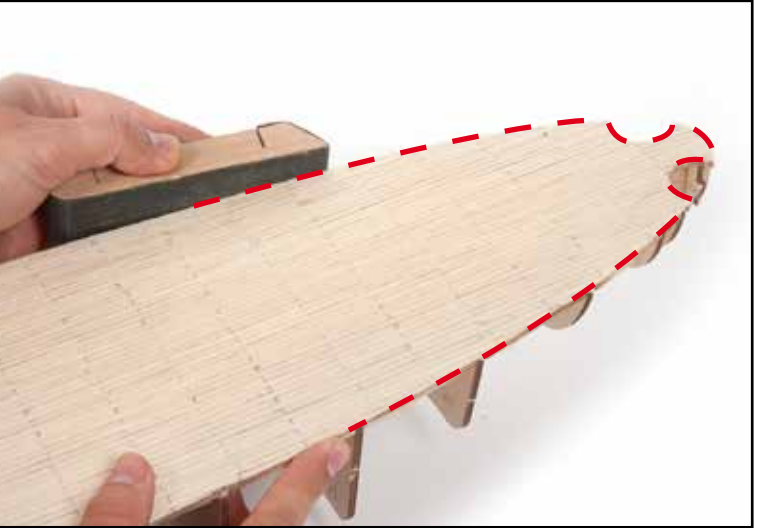
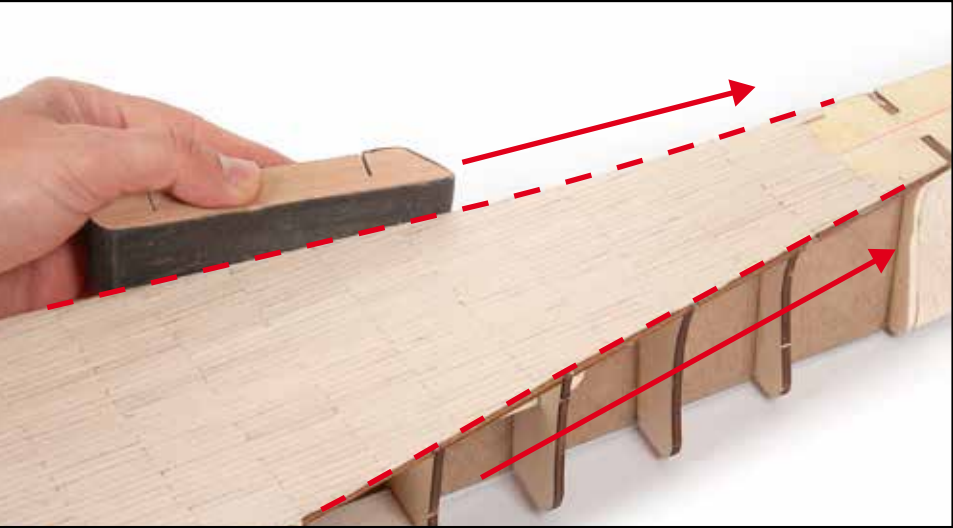
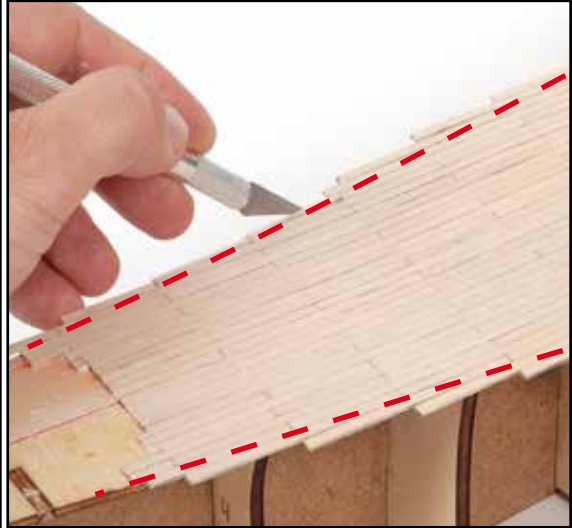
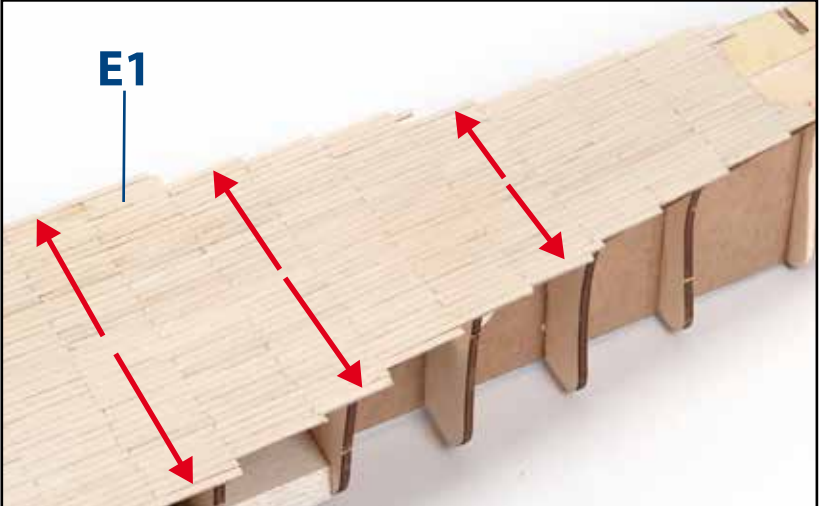
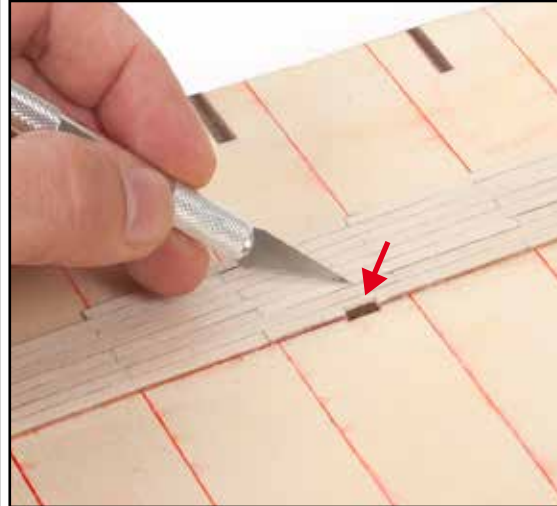
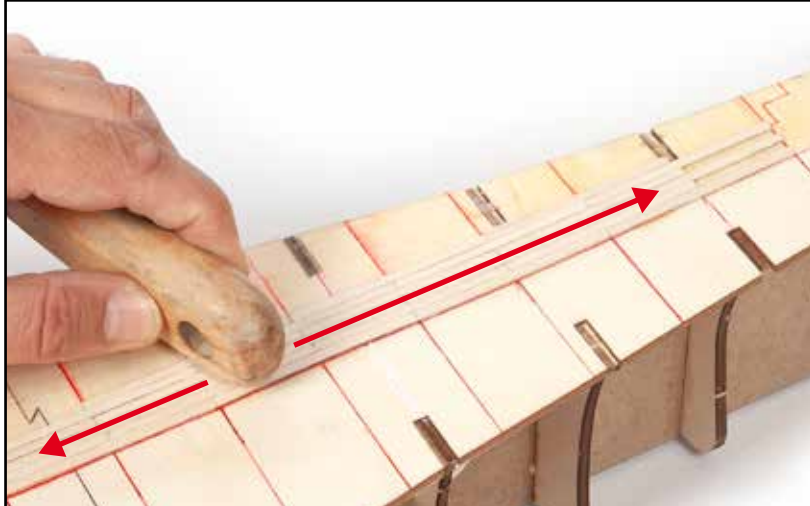
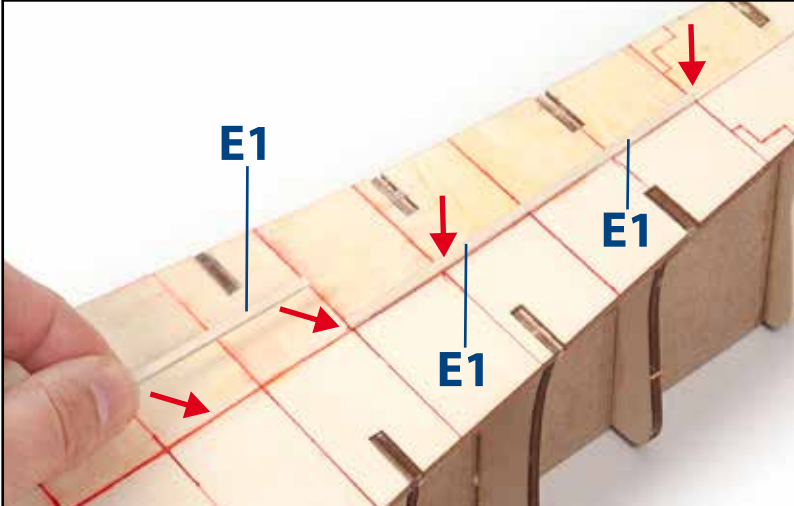
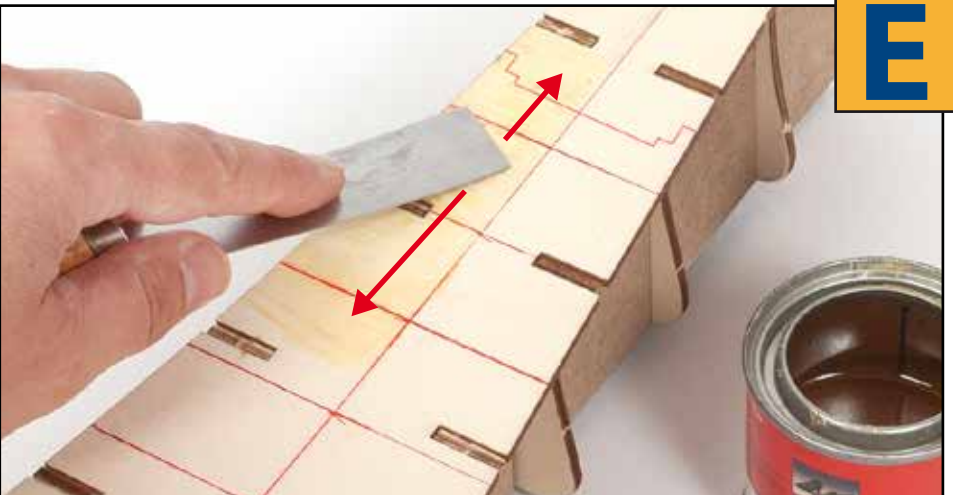
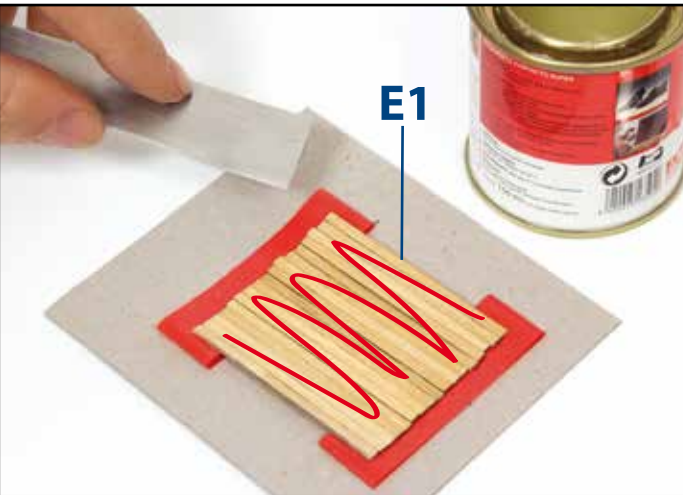
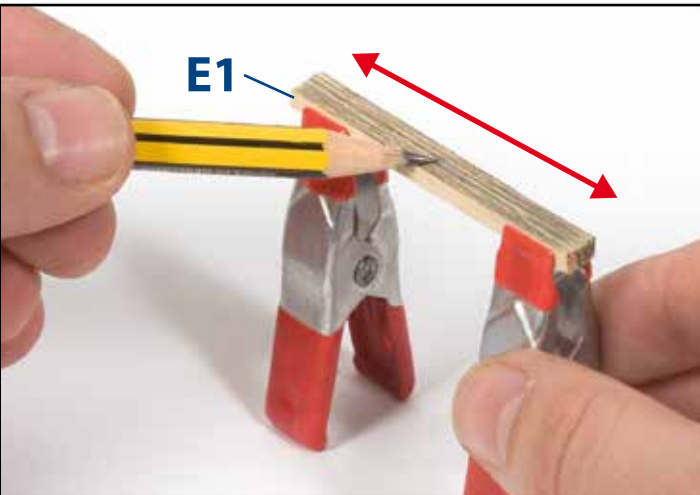
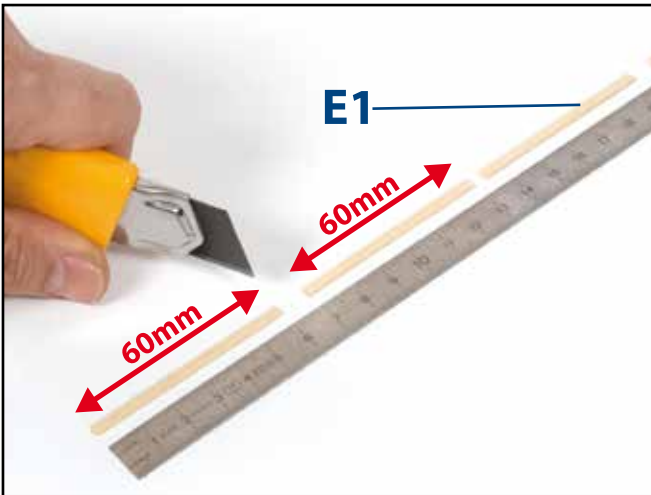

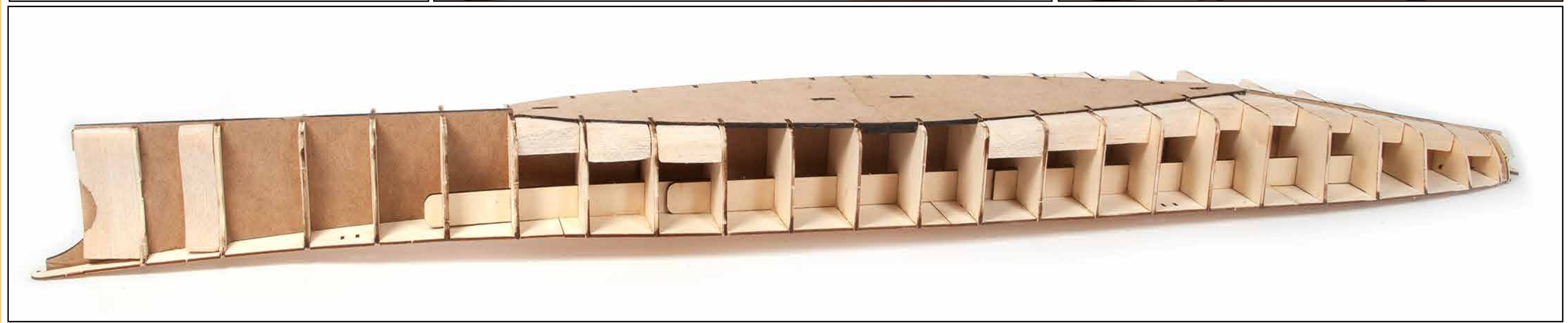
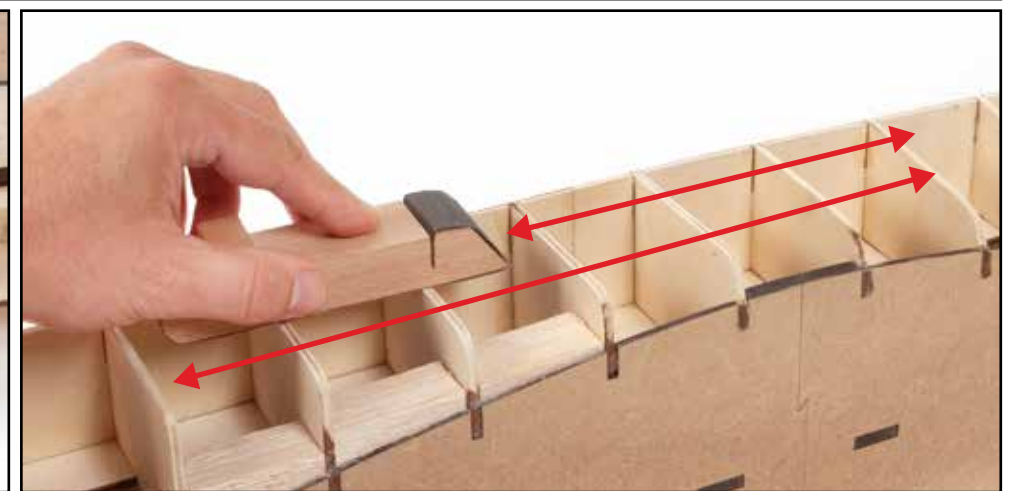
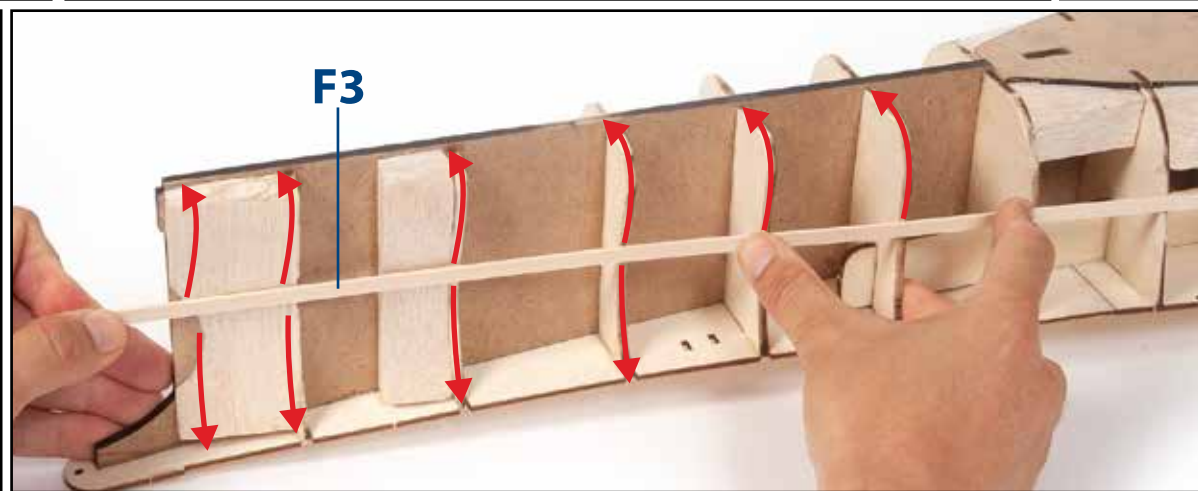
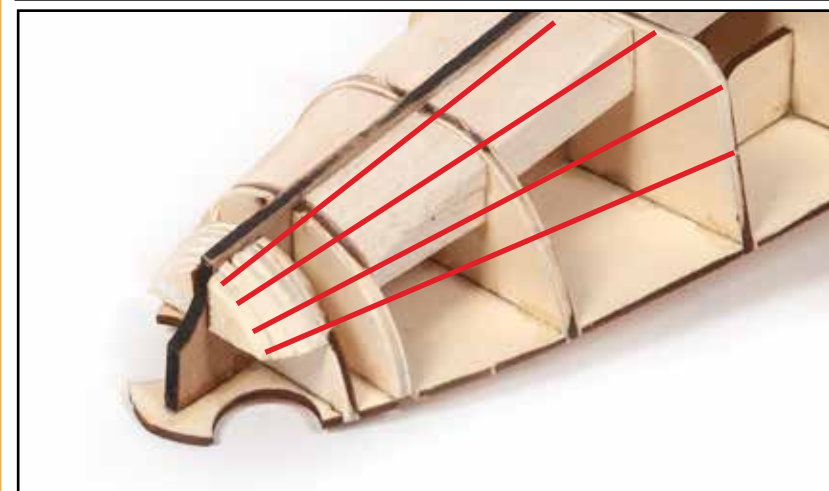
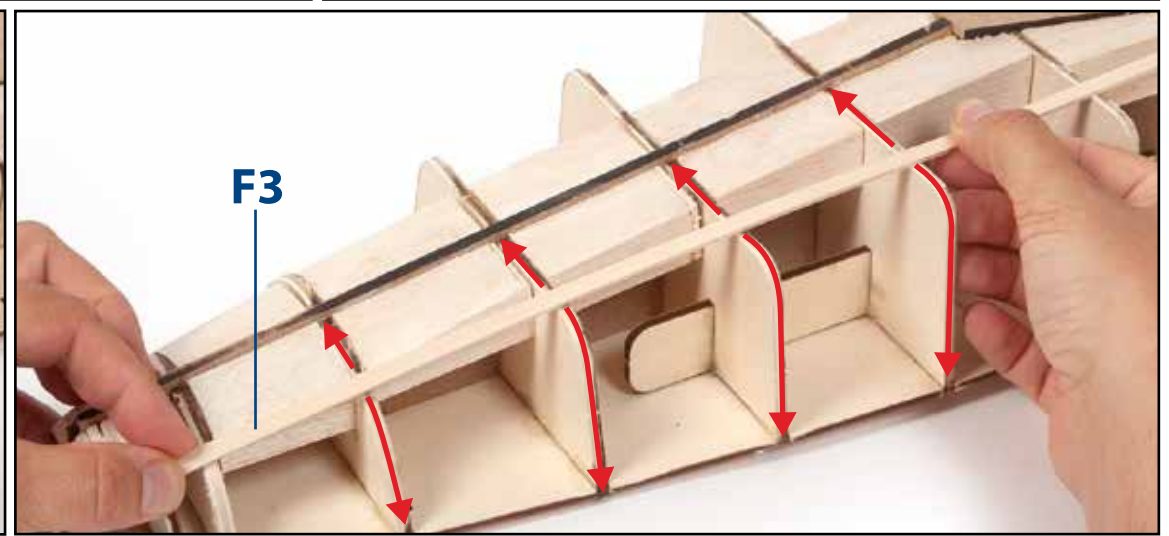
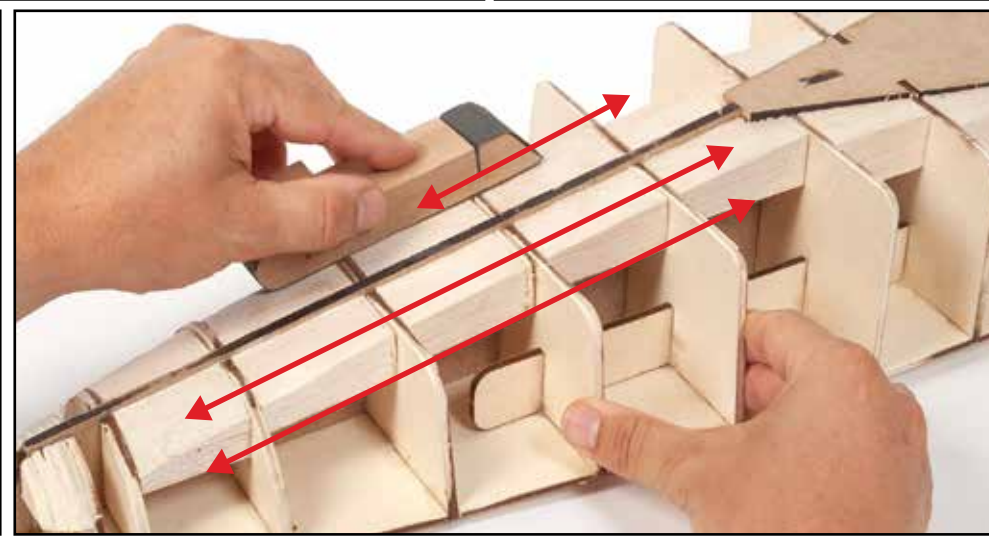
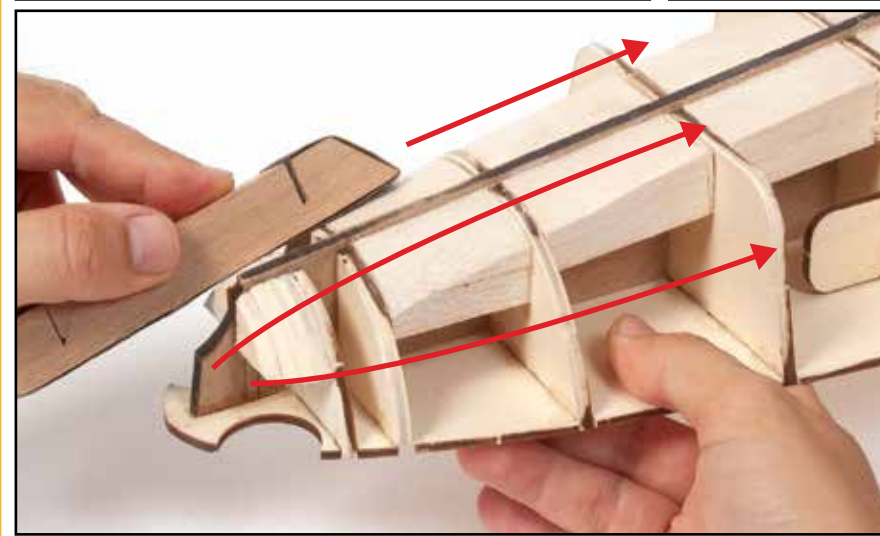
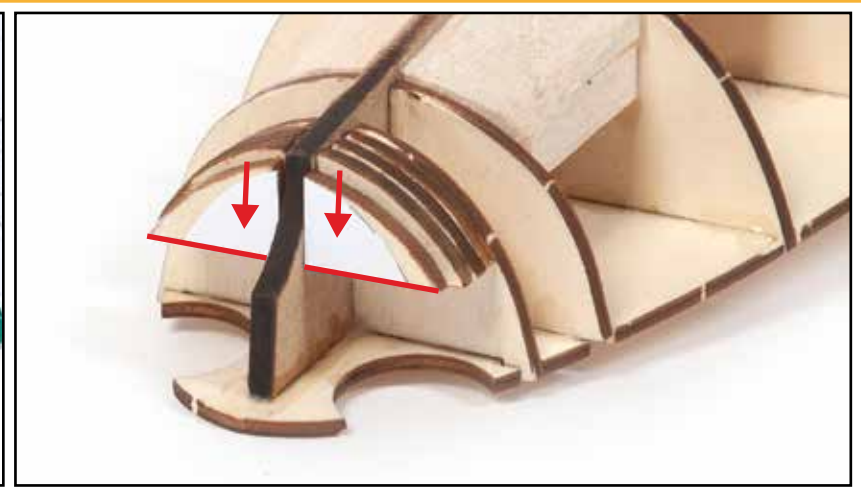
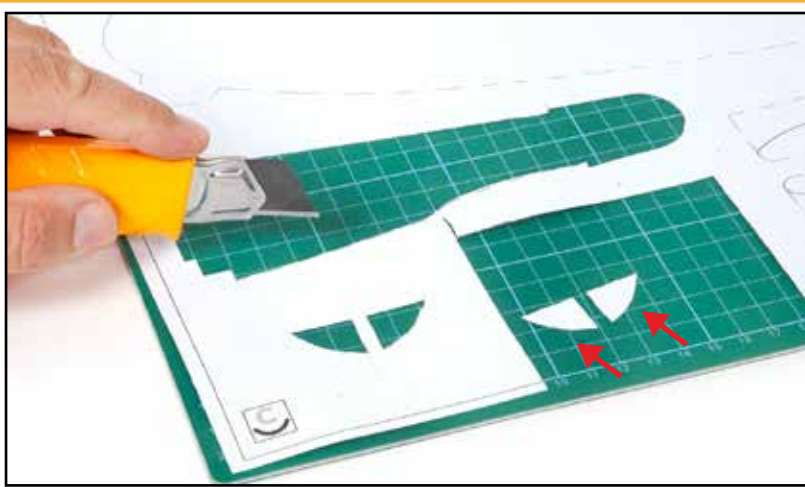
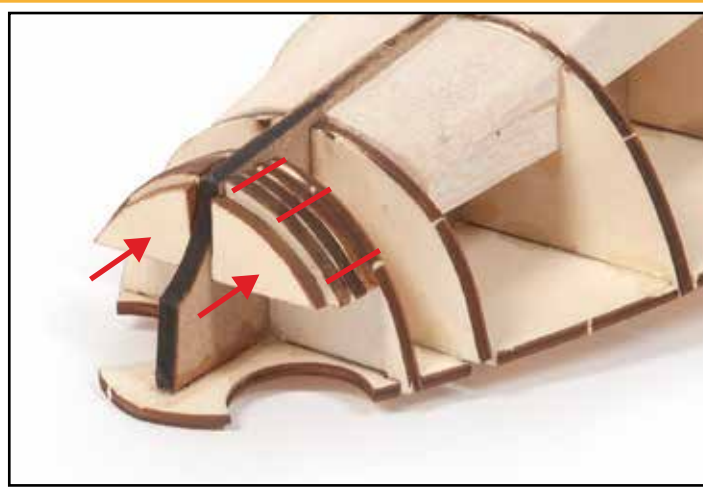
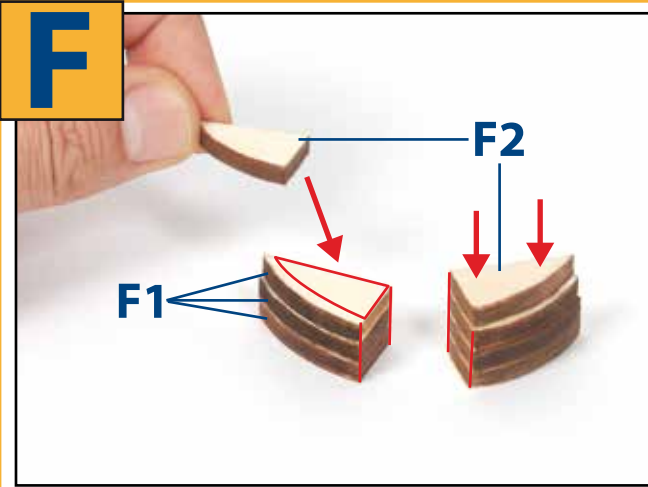
F

H

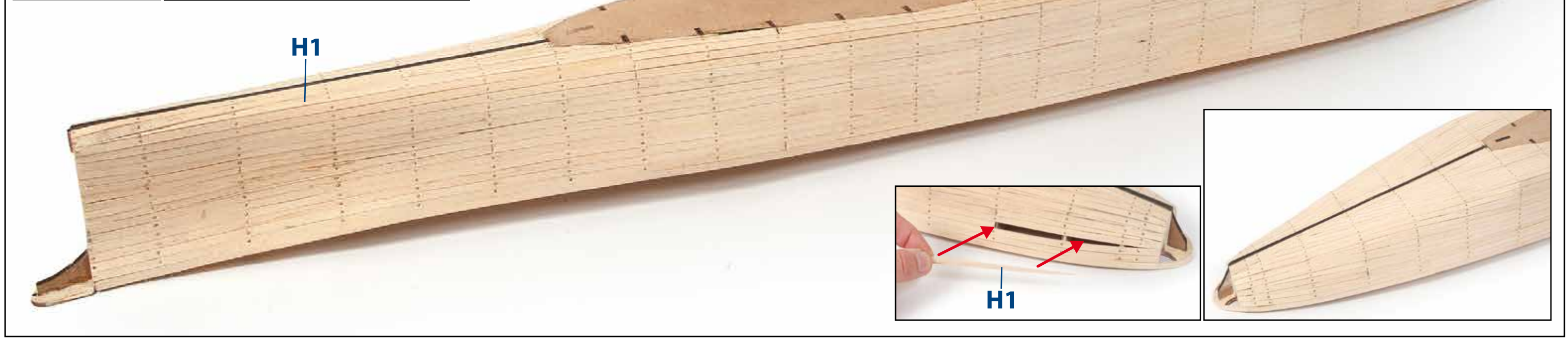
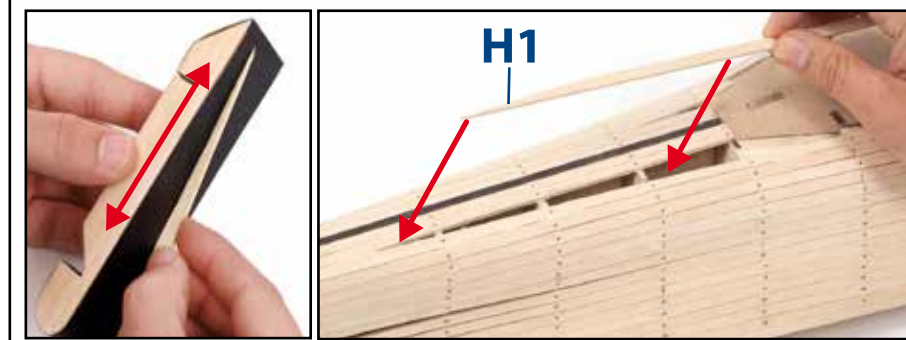
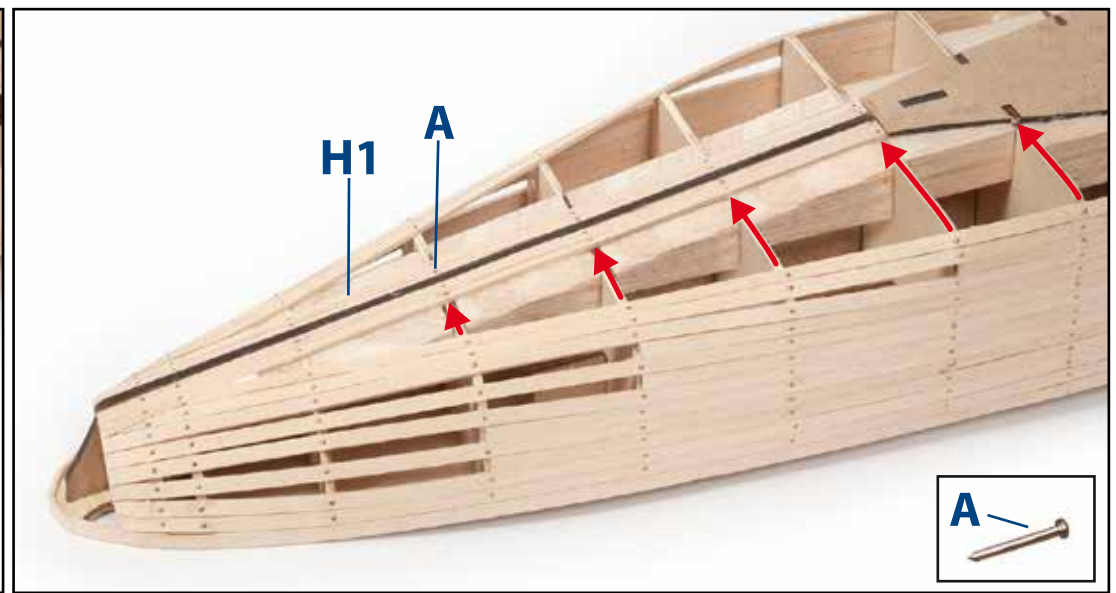
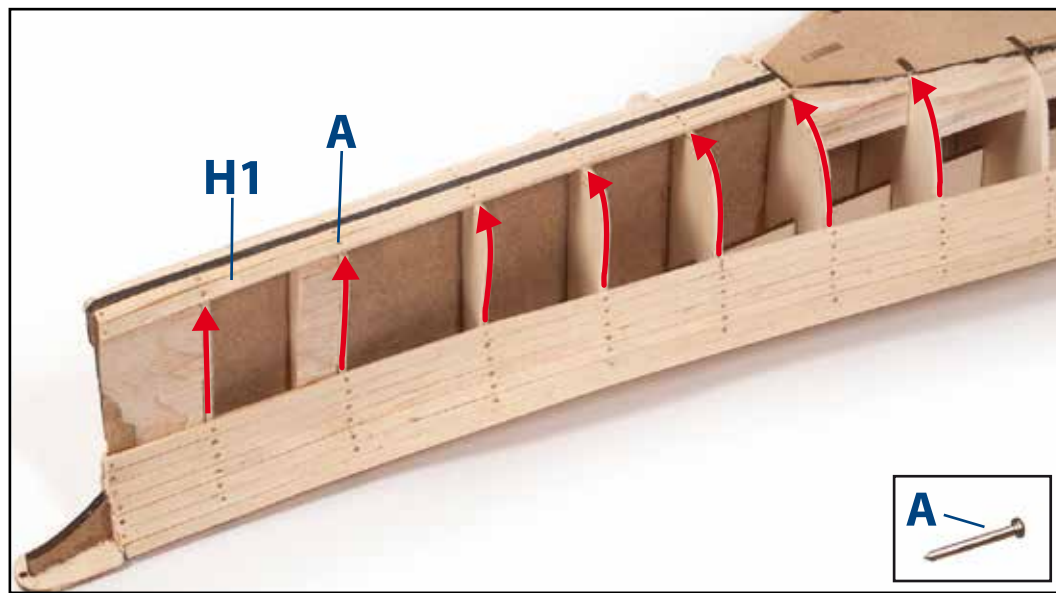
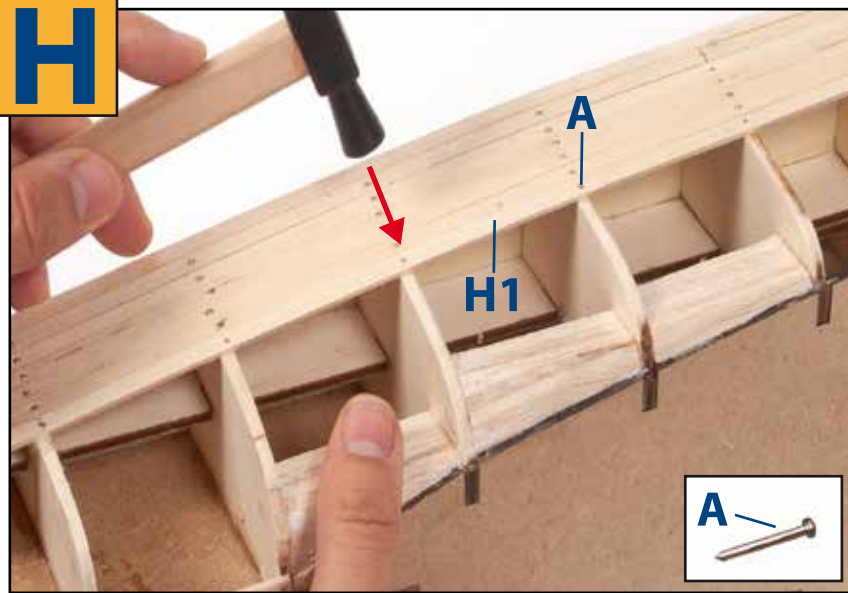

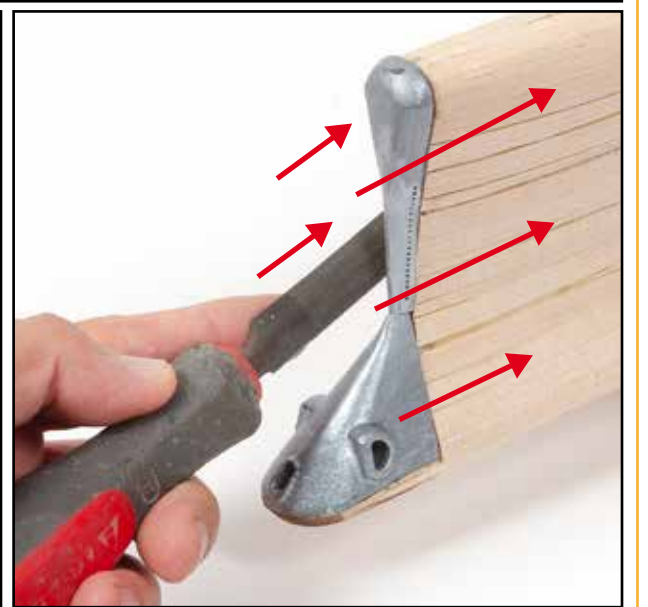
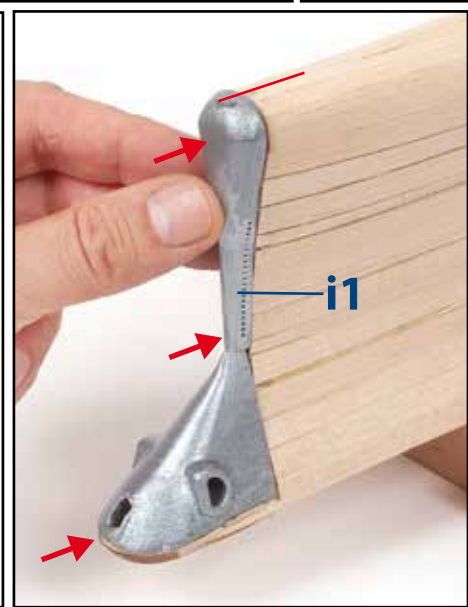
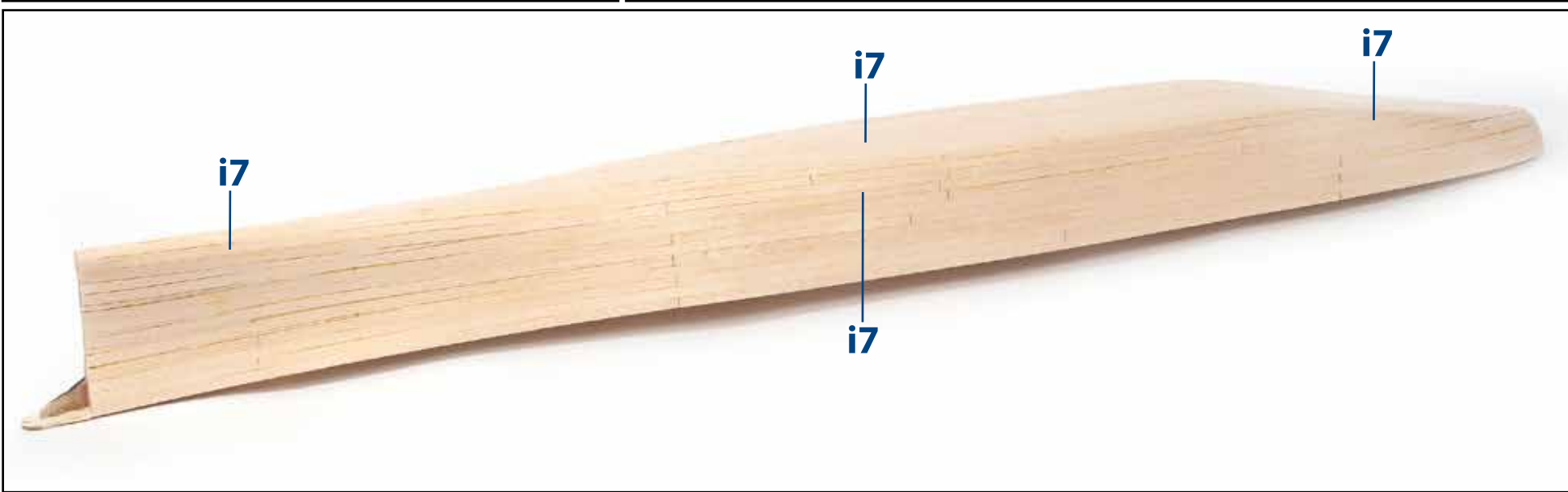
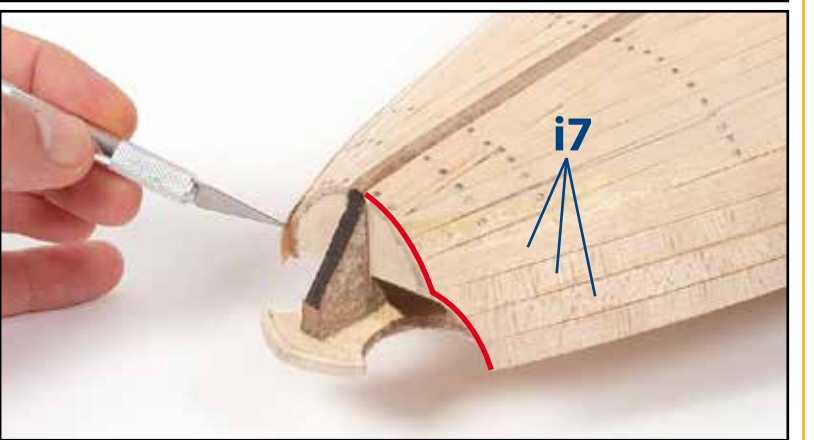
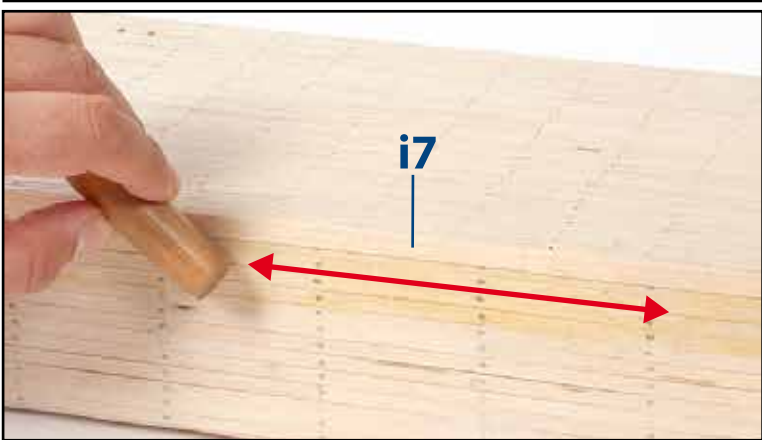
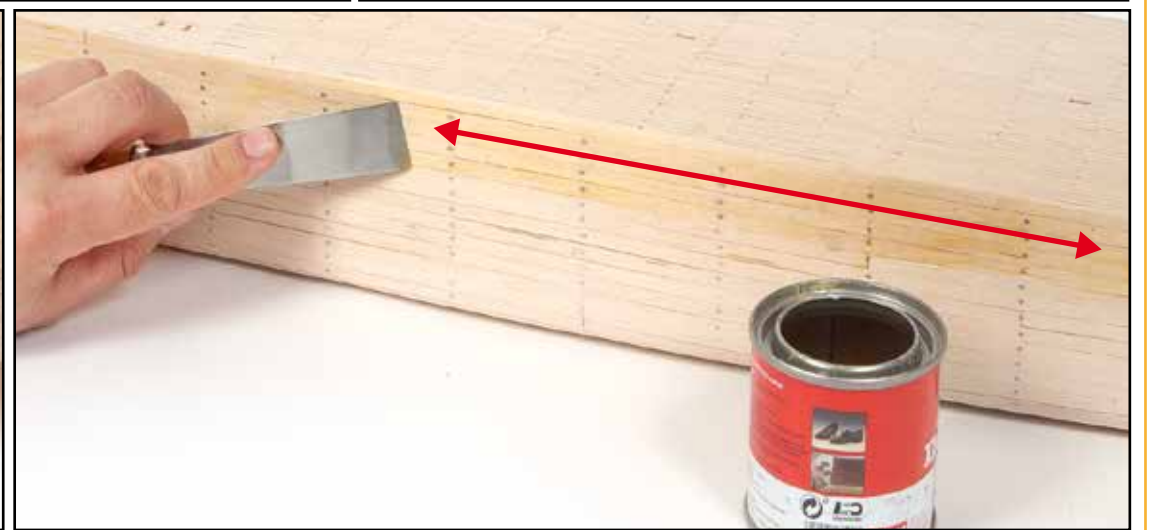
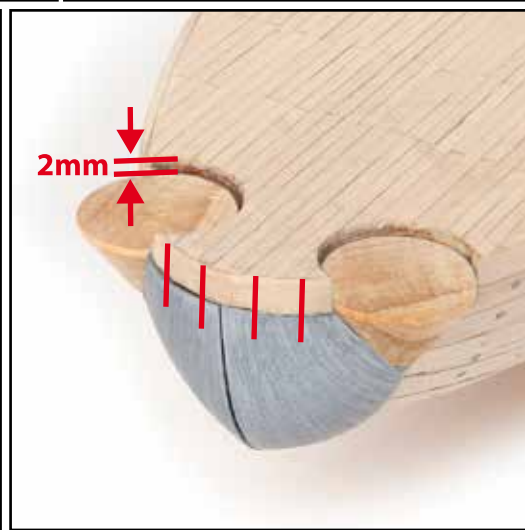
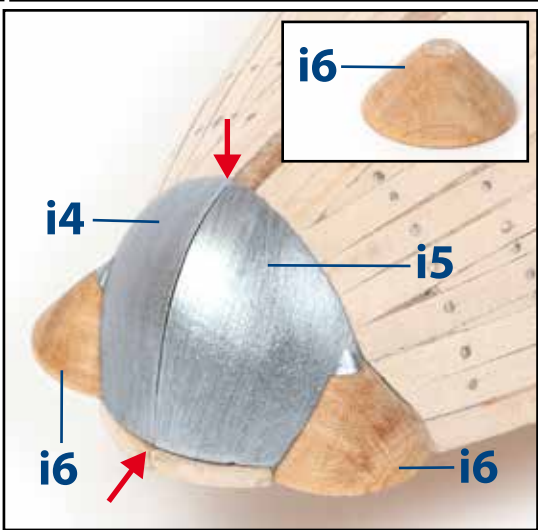
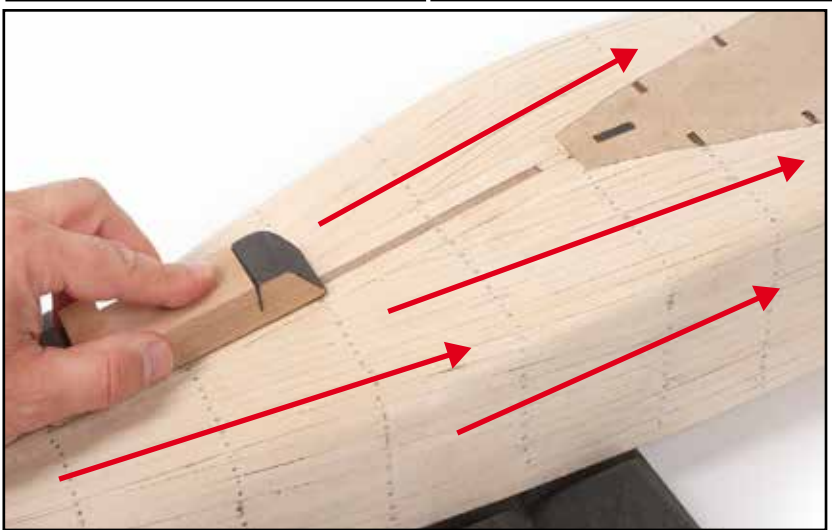
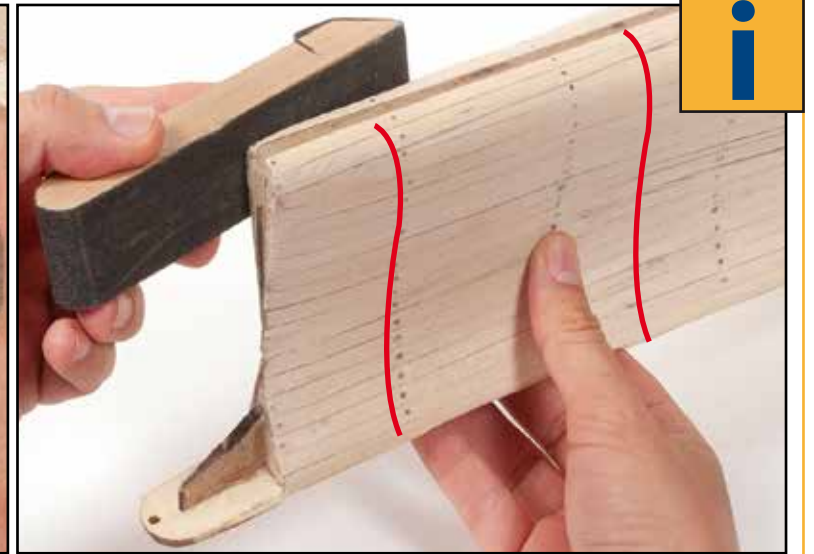
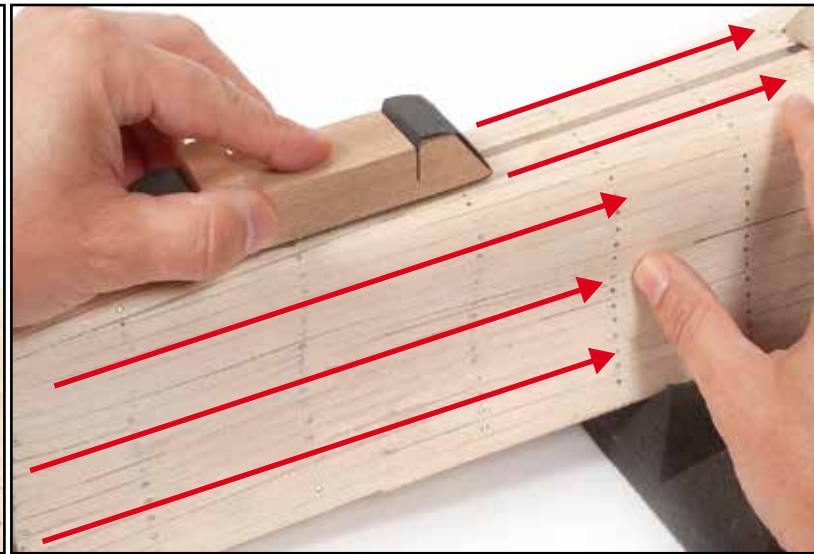
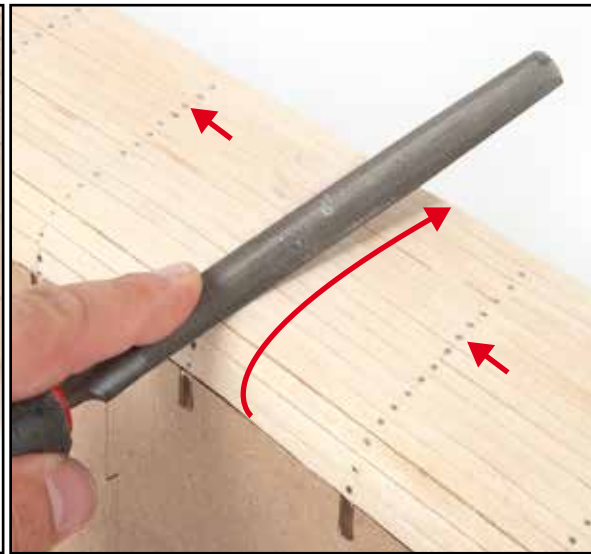
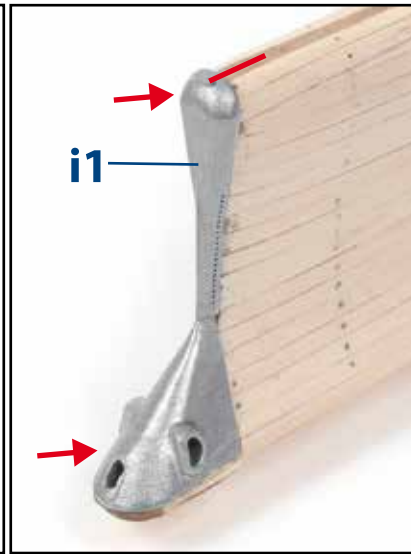
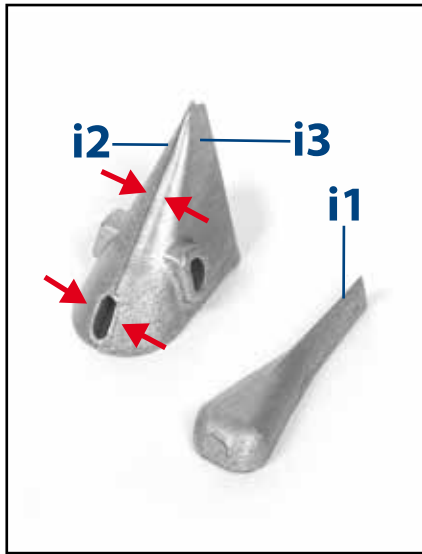

J

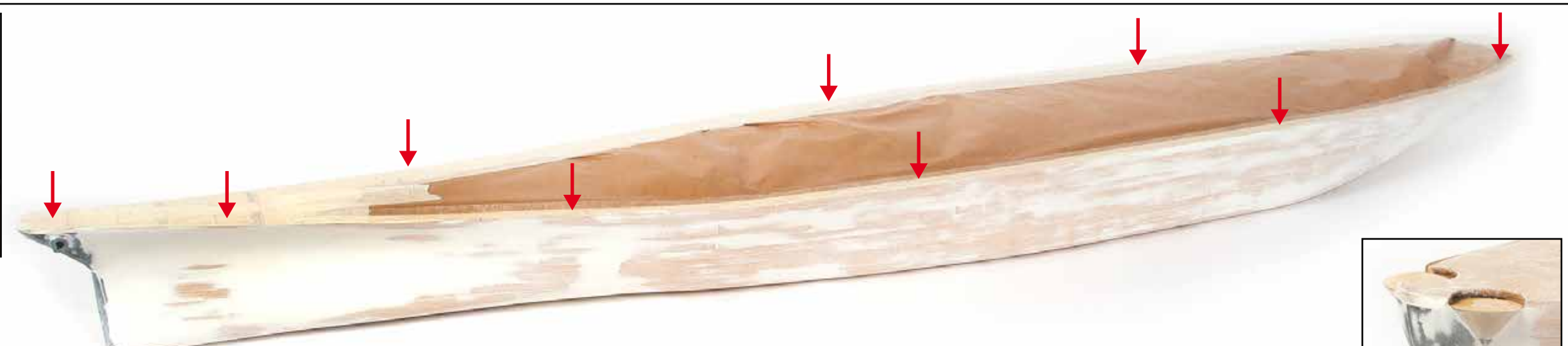
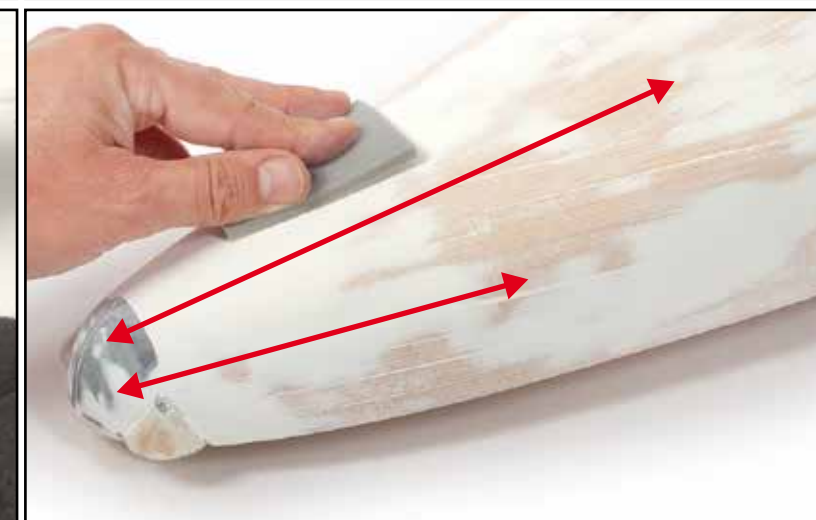
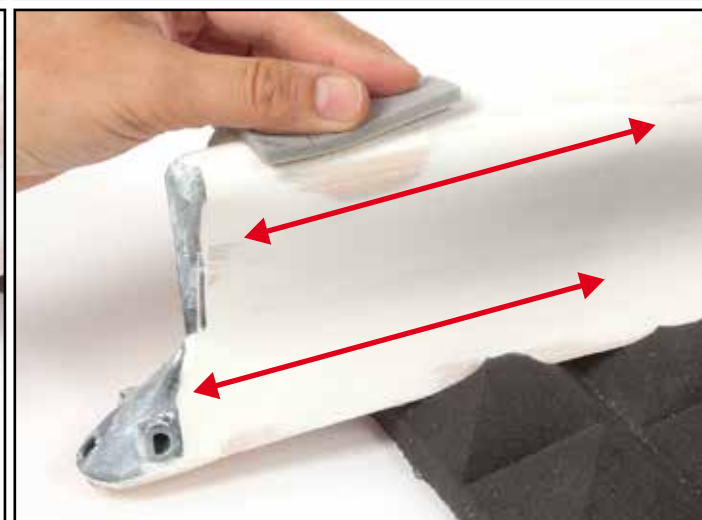
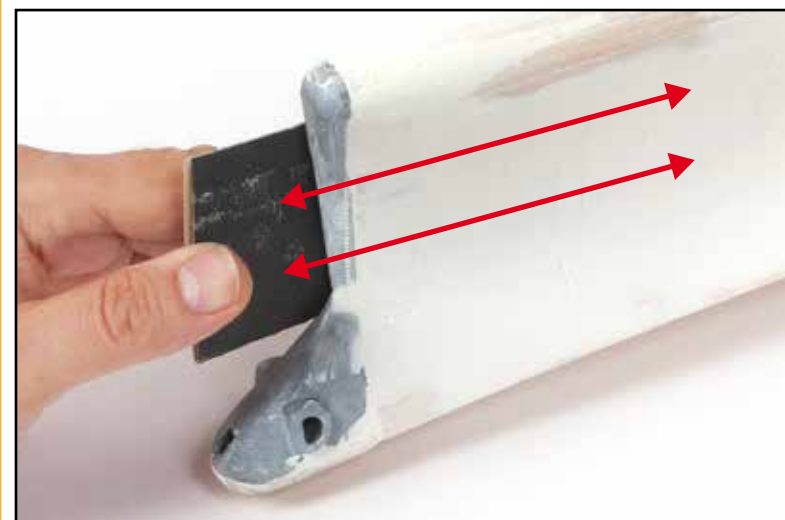
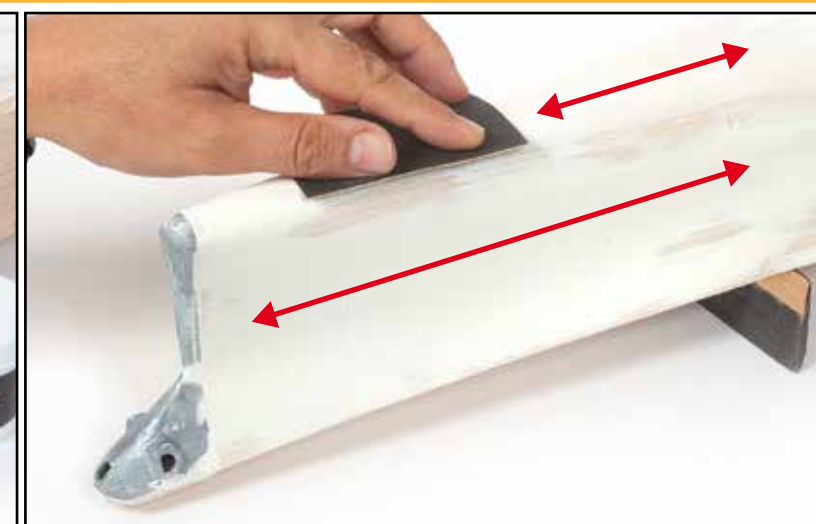
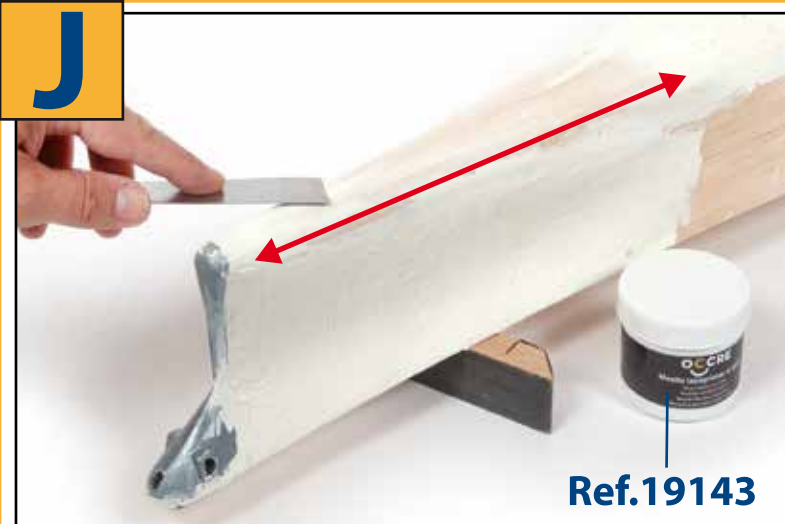

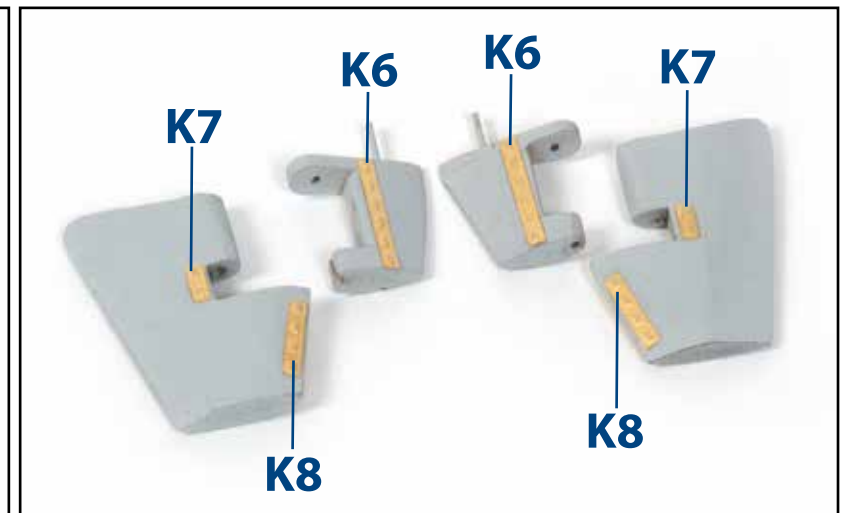
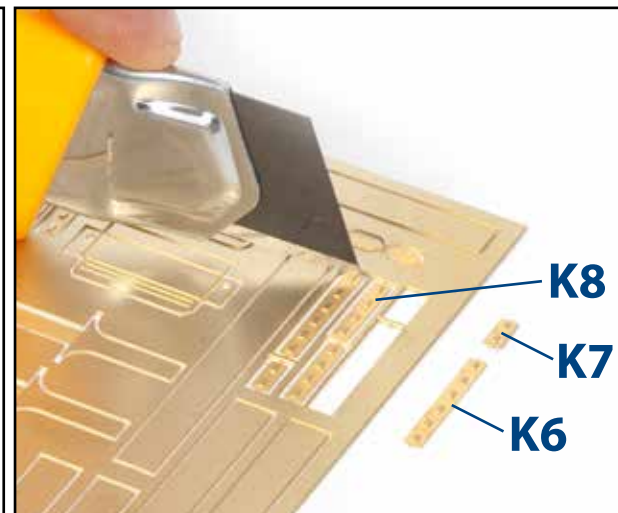
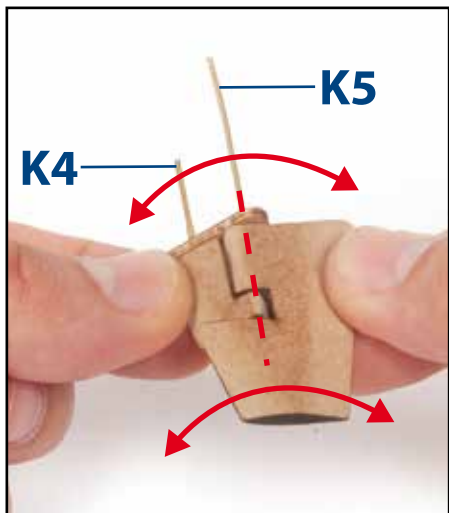
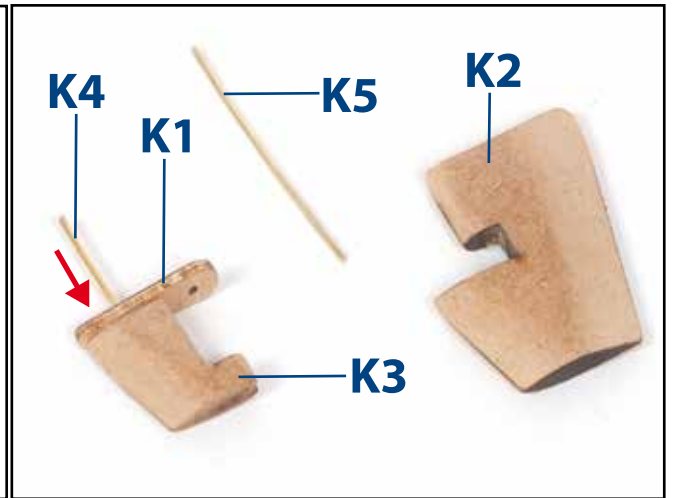
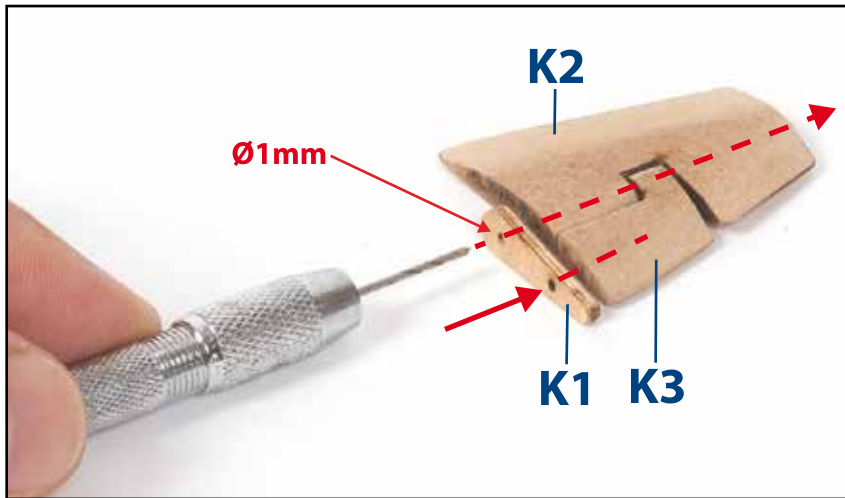
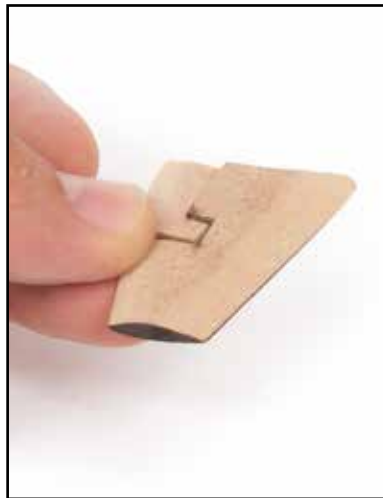
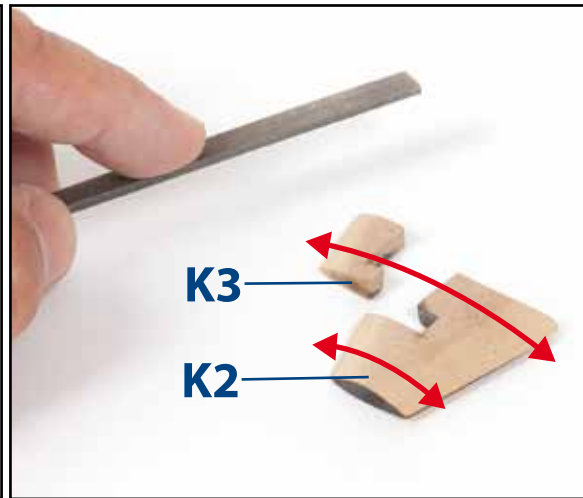
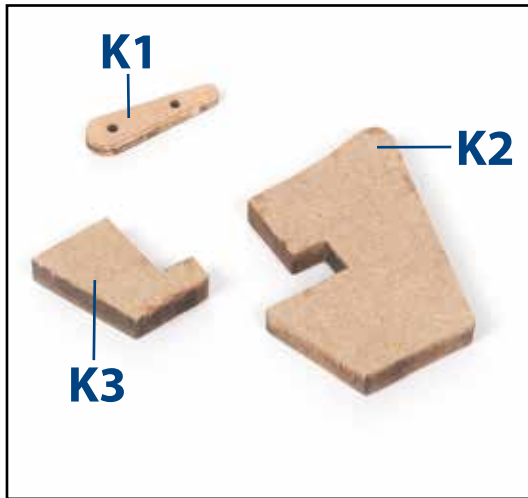
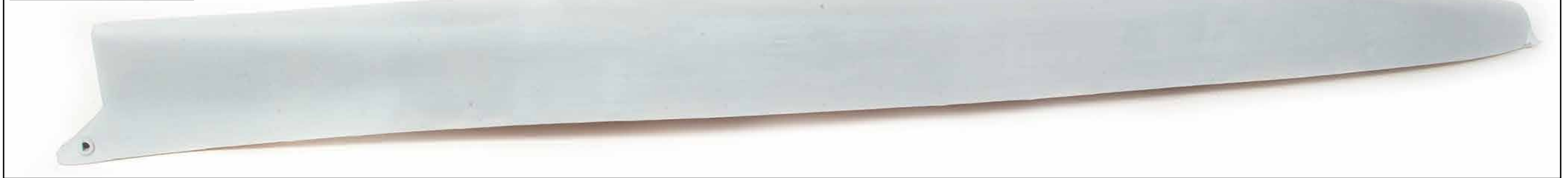
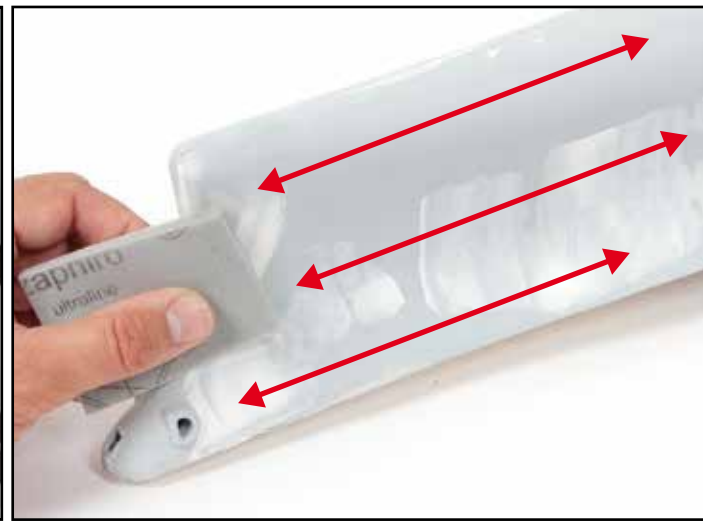
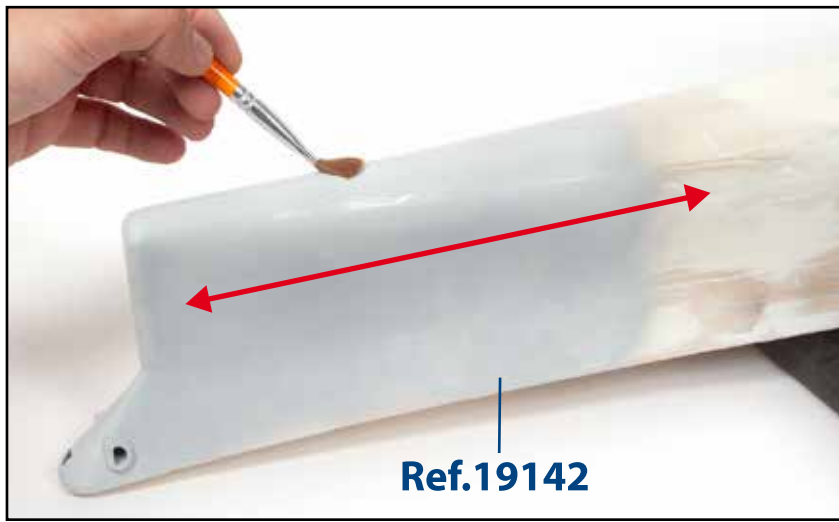

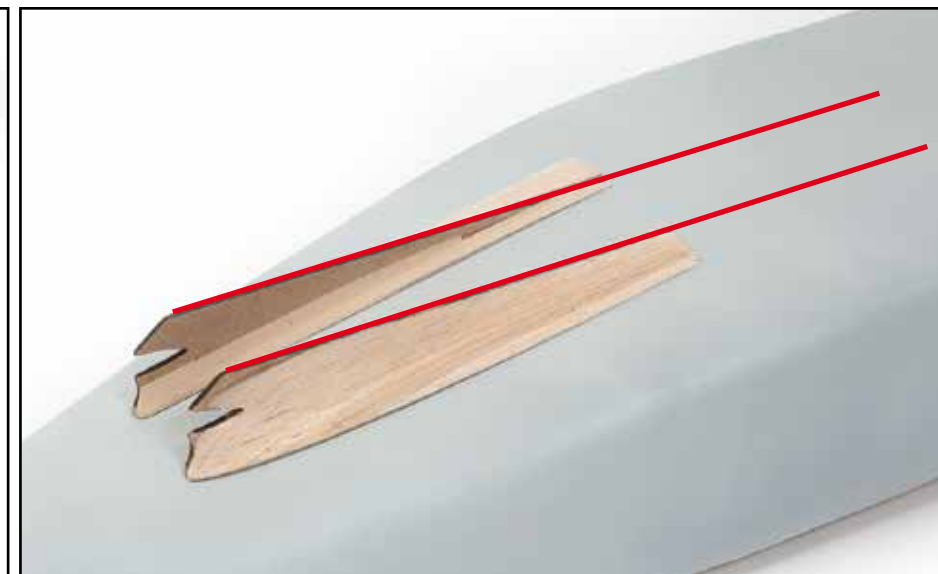
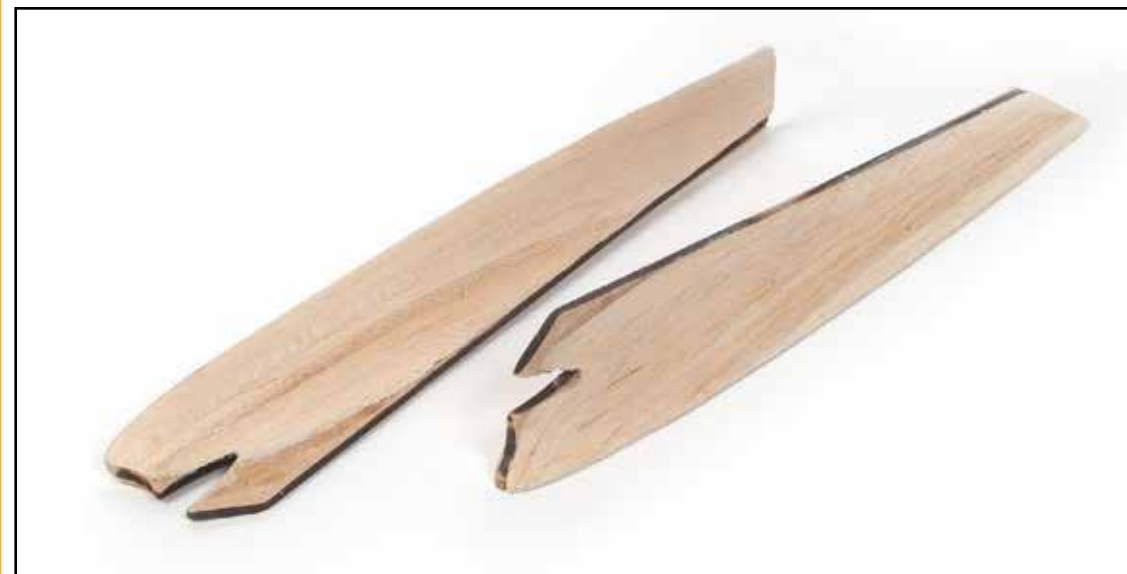
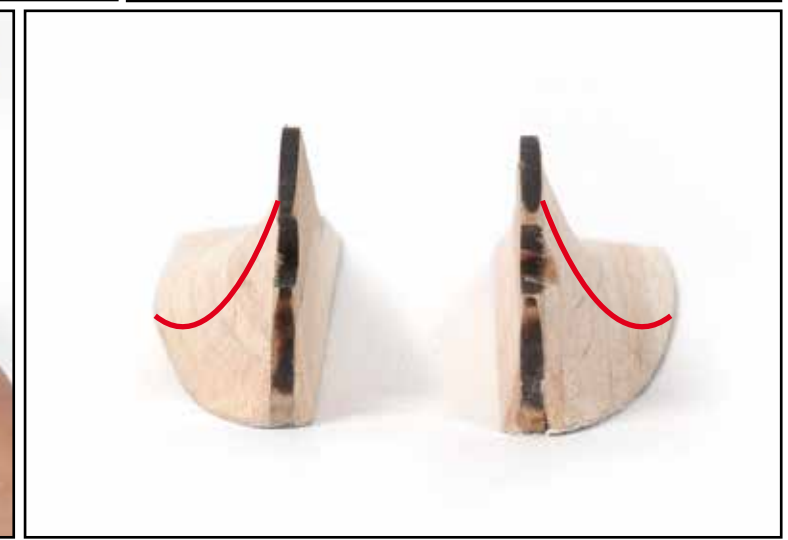
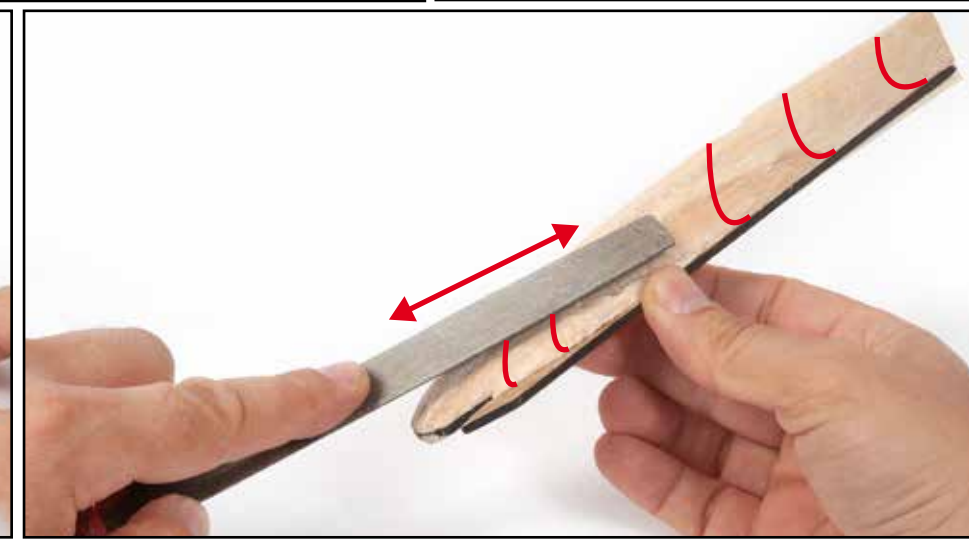
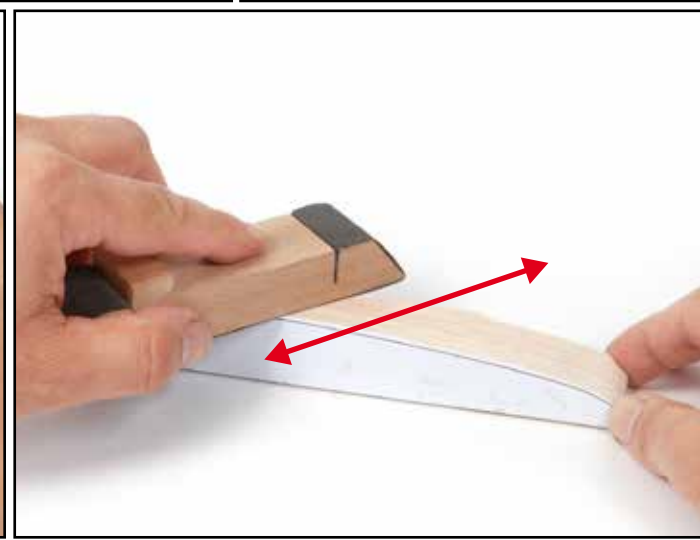
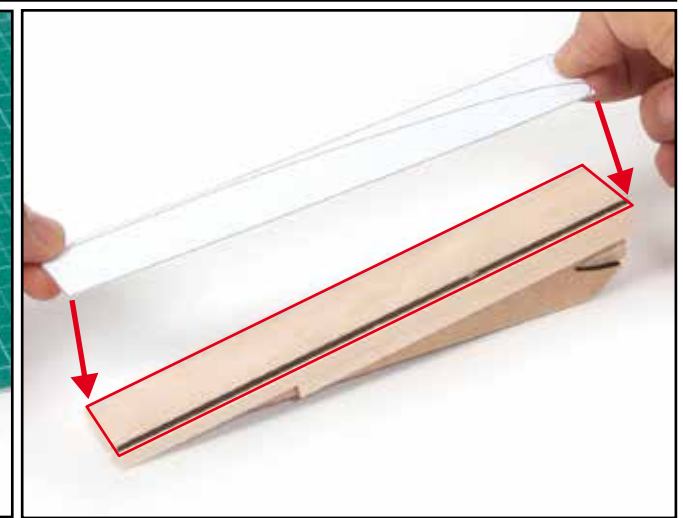
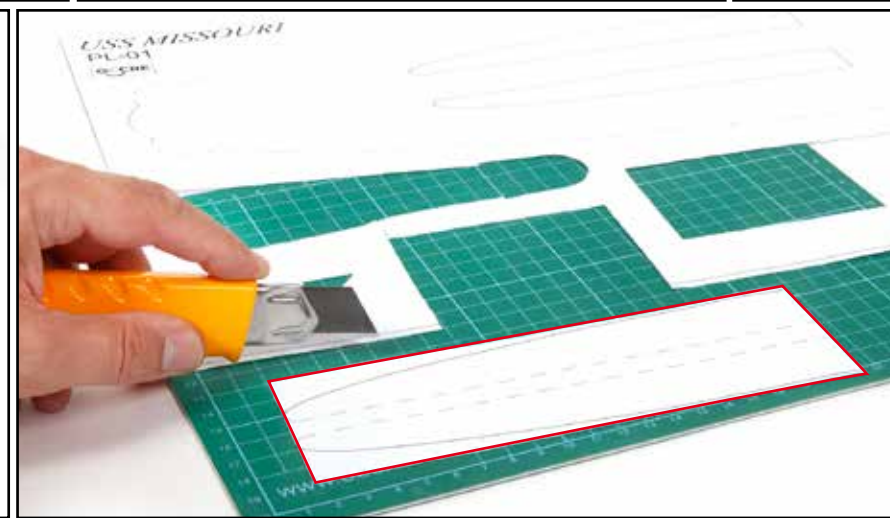
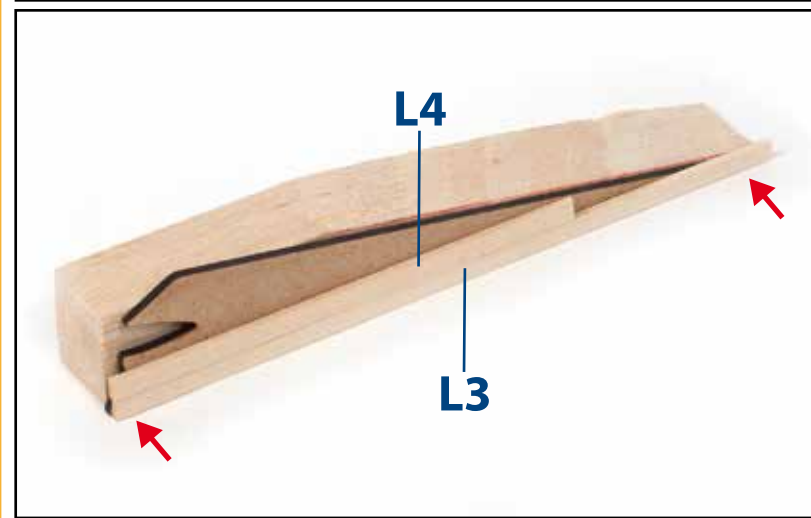
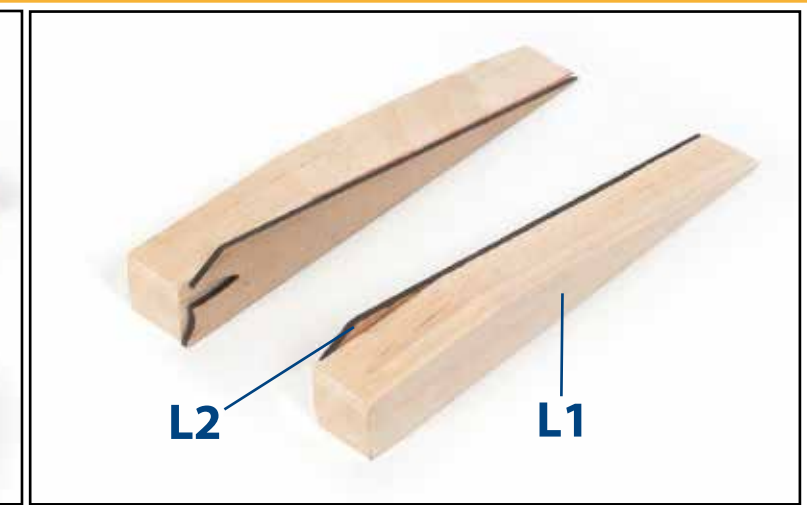
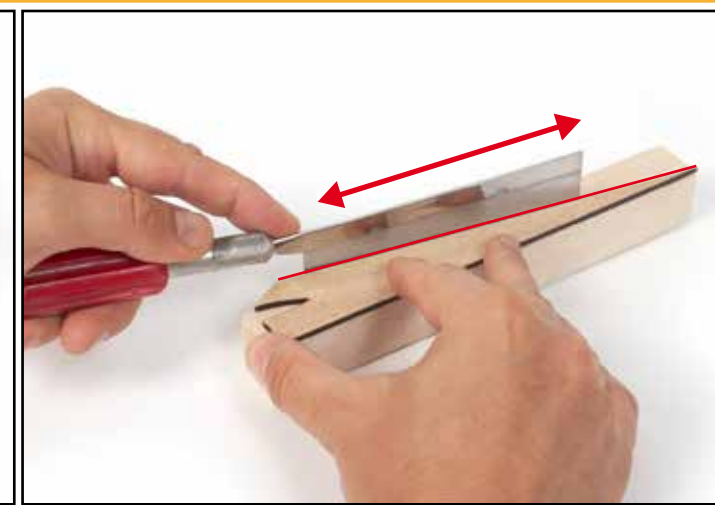
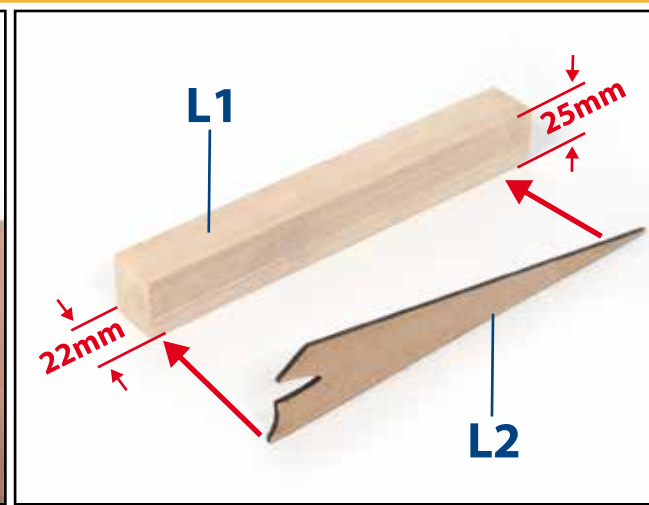
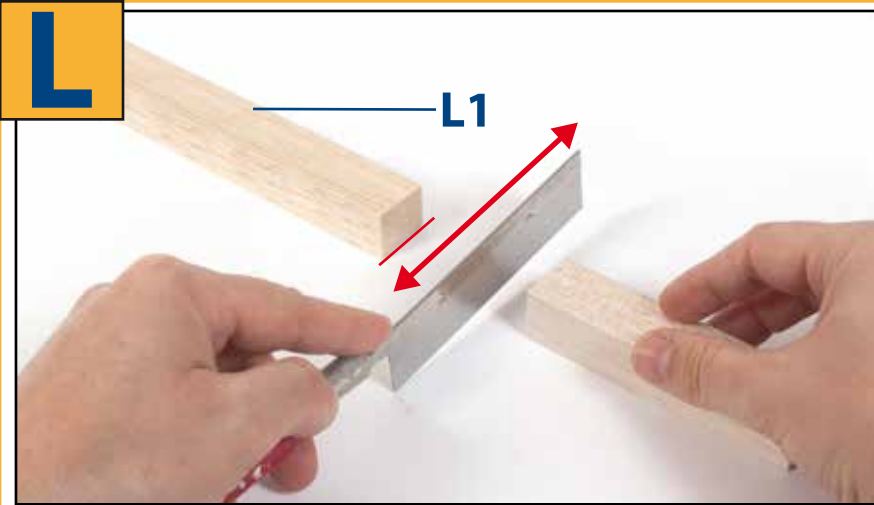
L

Ref.19143

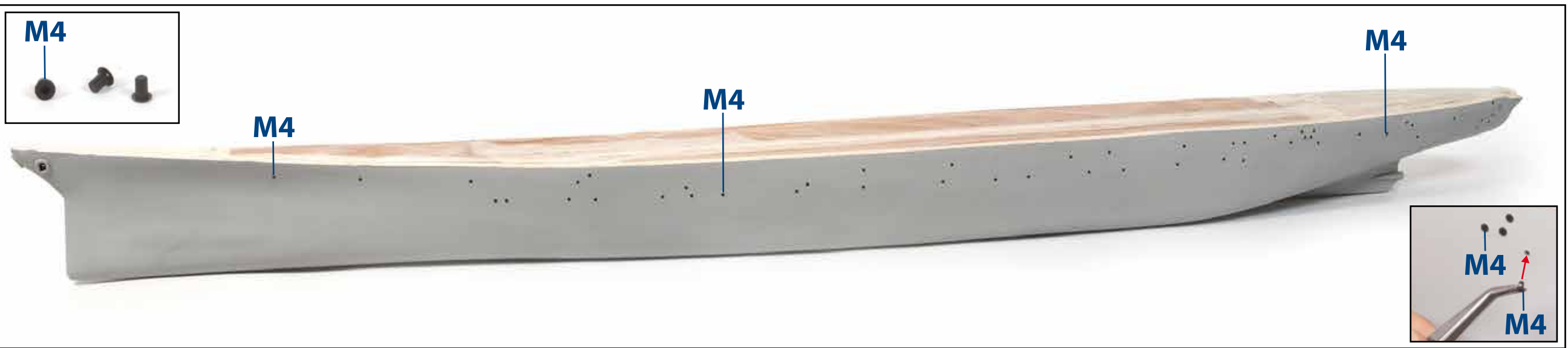
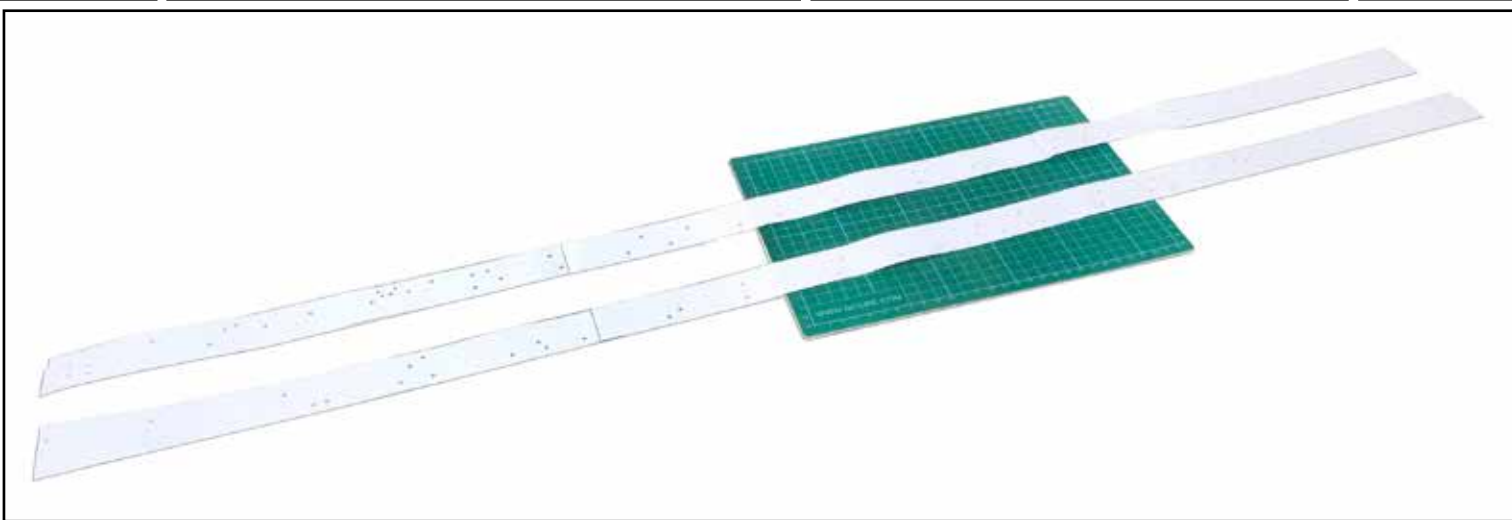
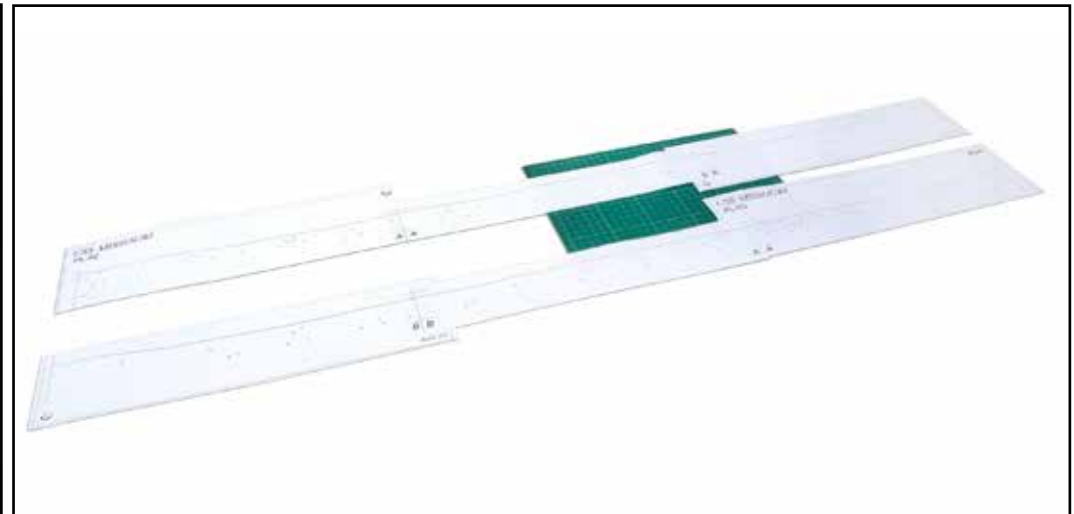
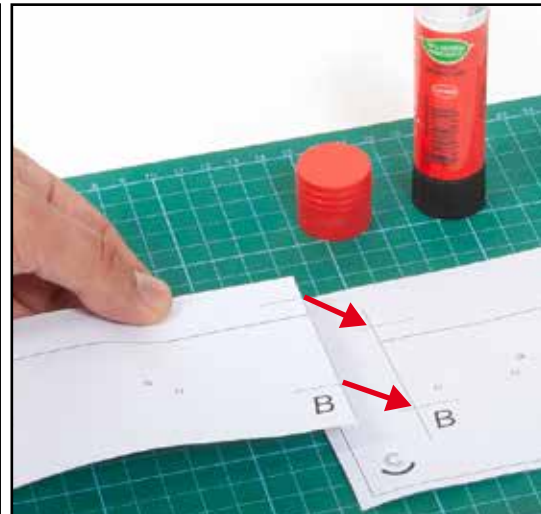
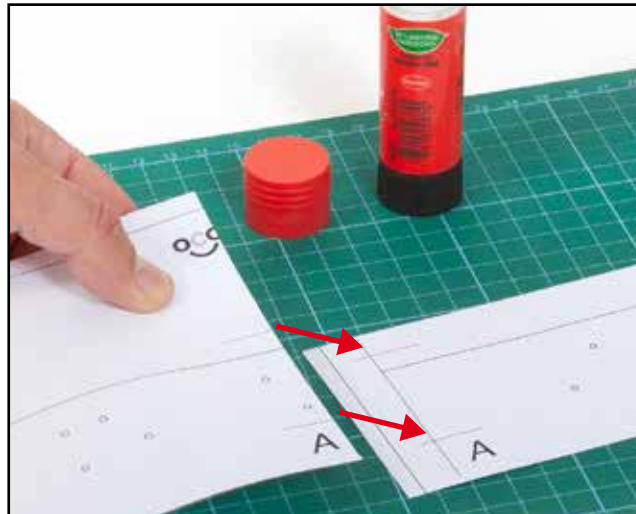
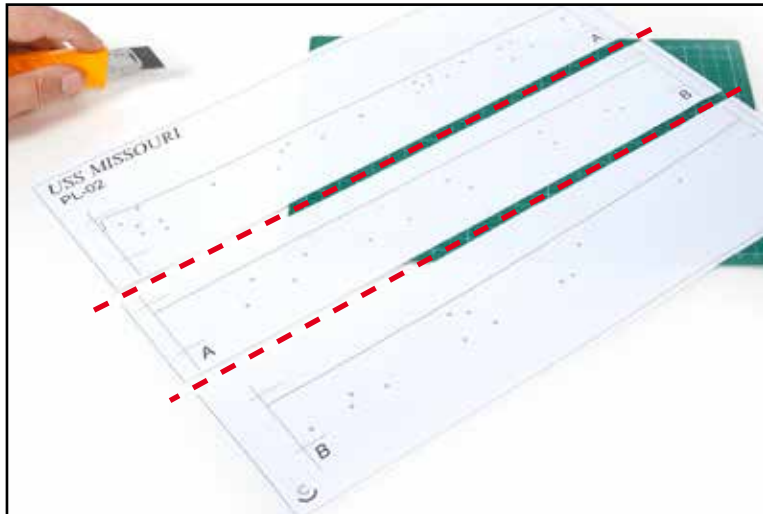
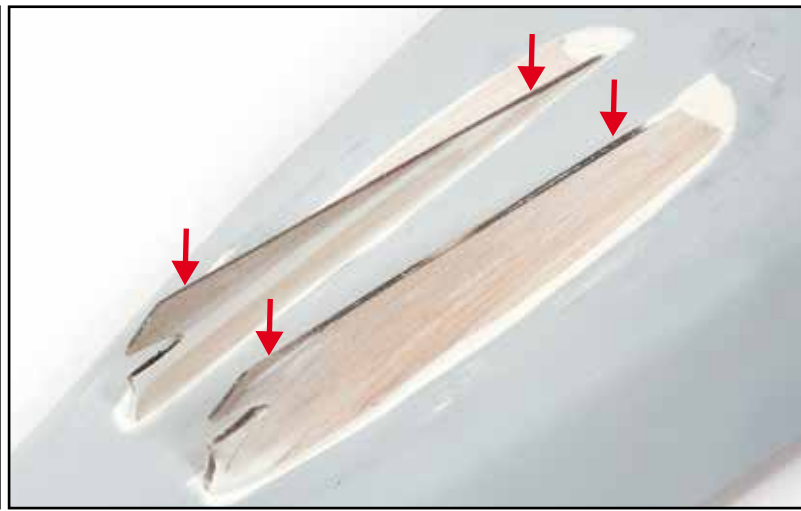
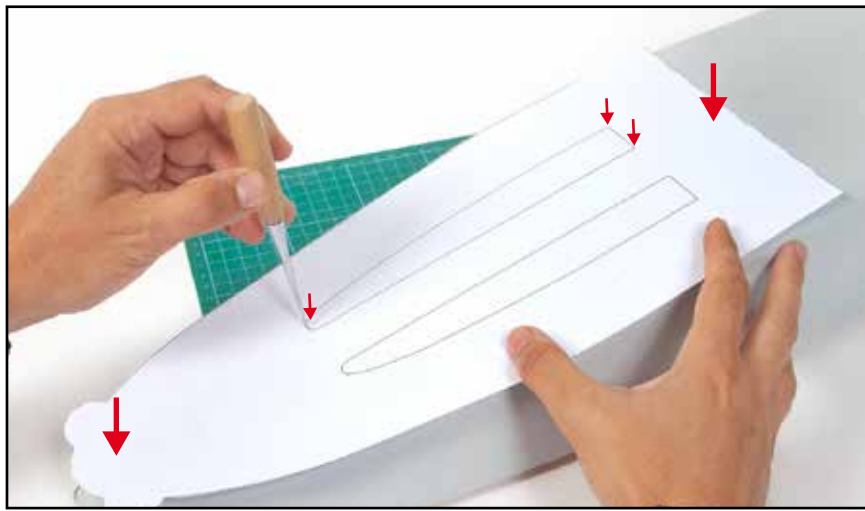

N

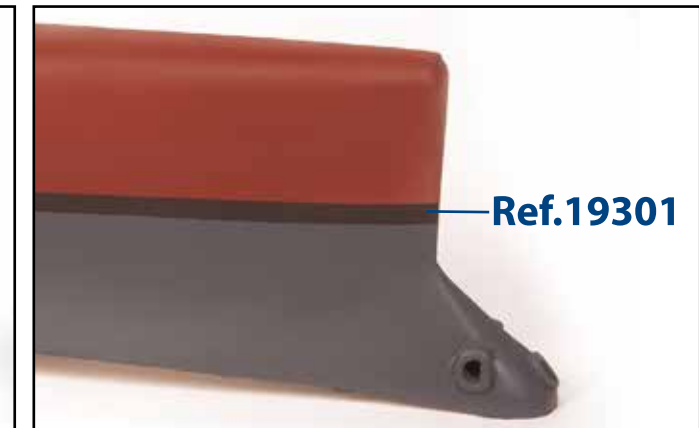
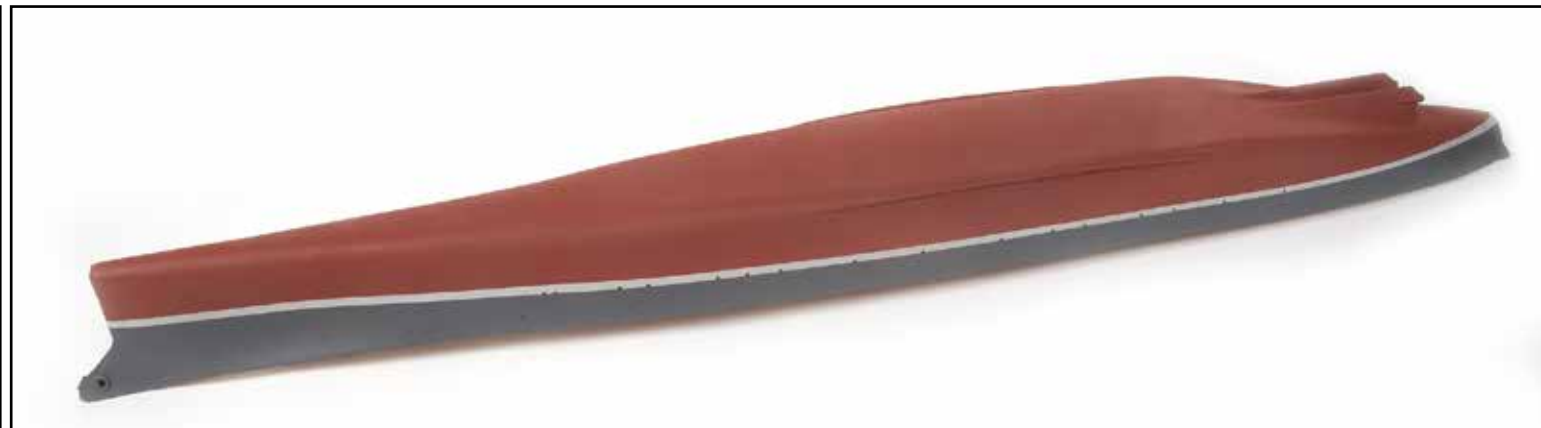
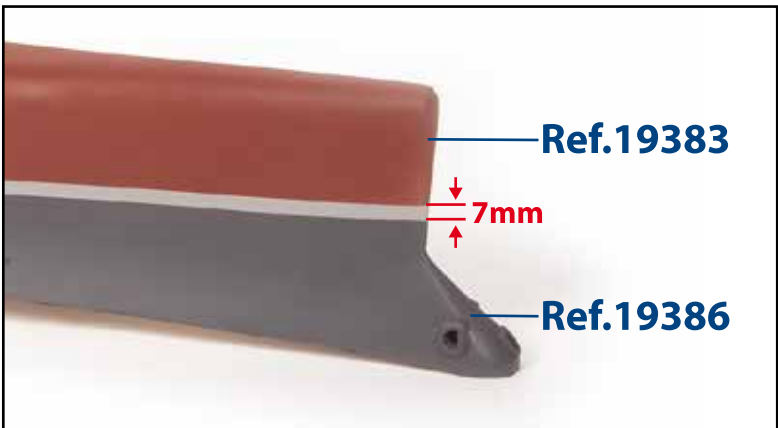
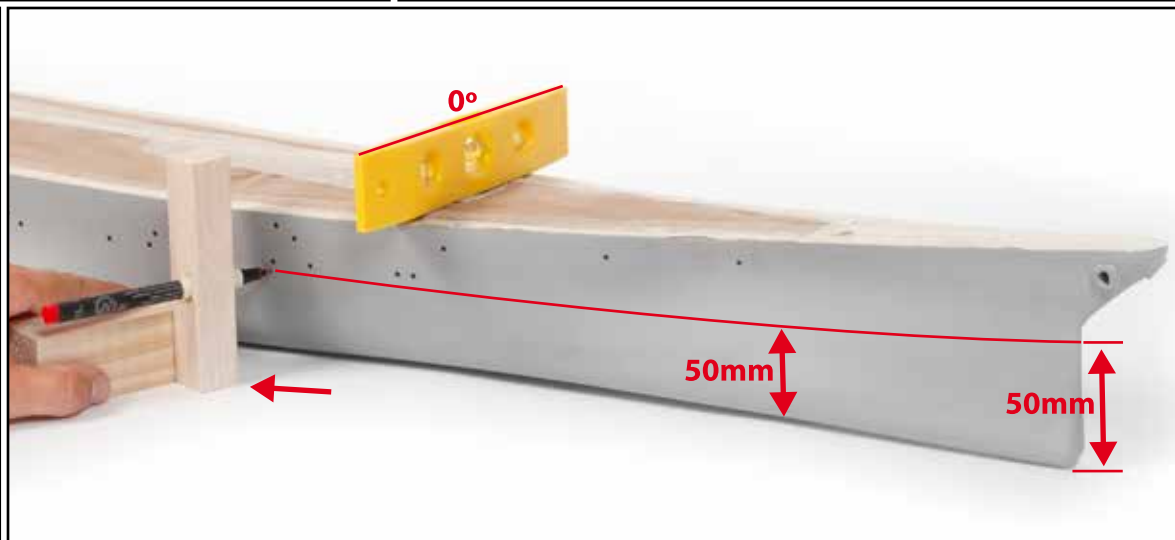
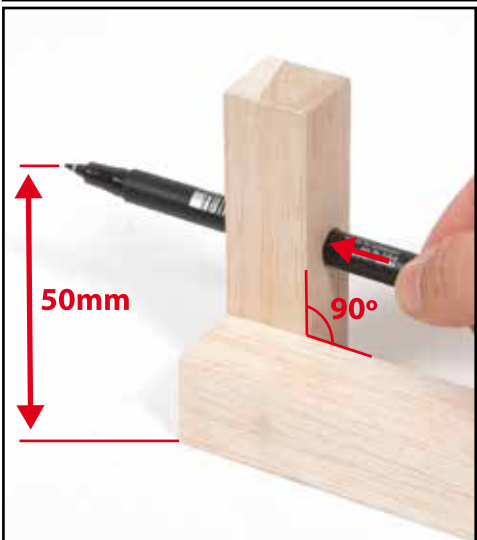
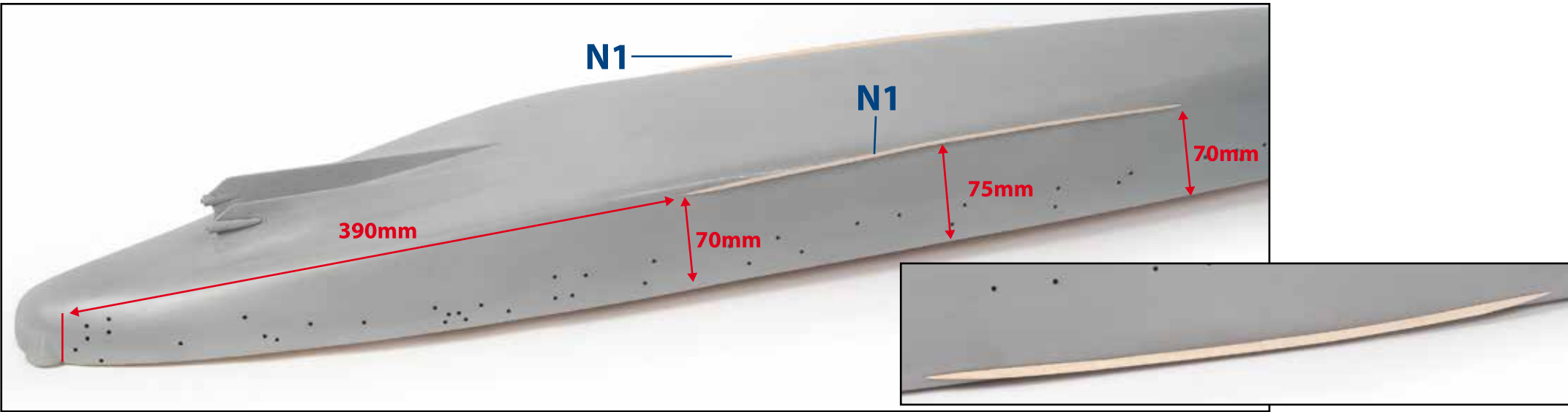
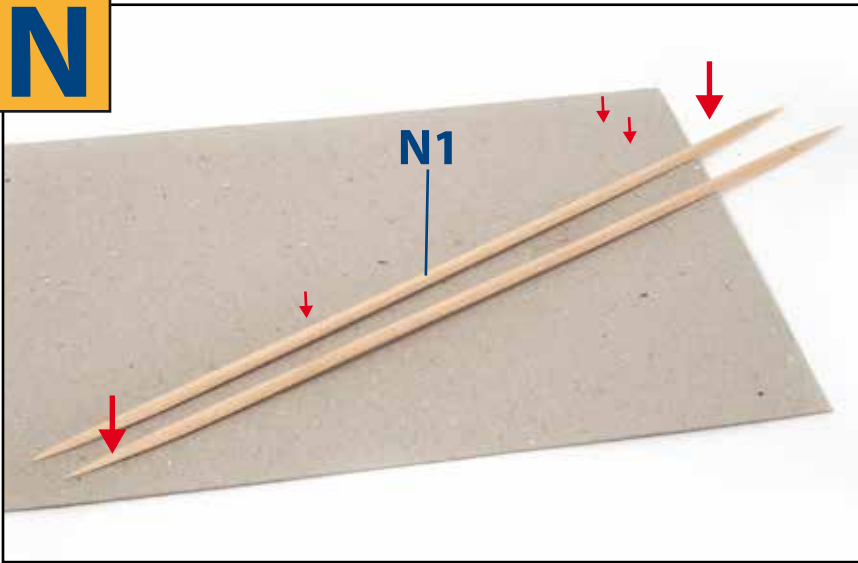

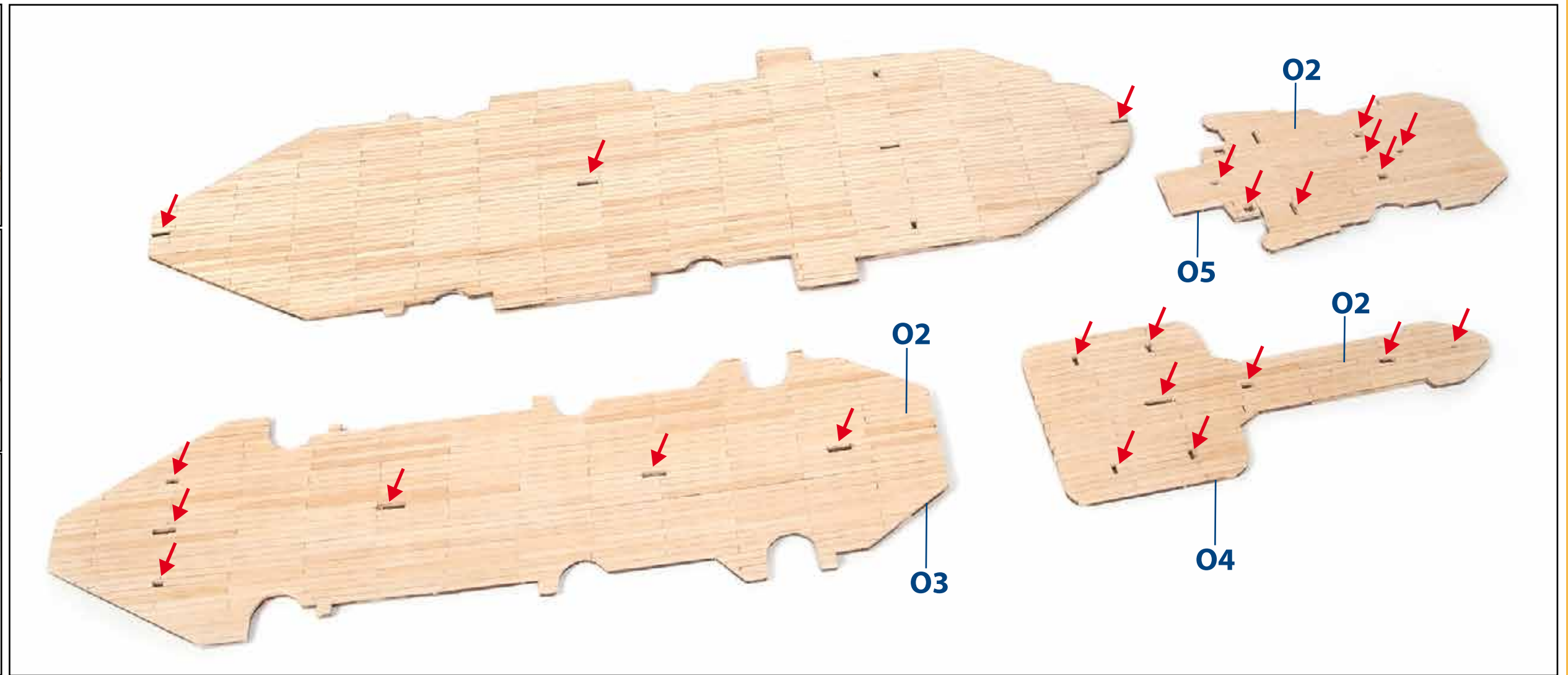
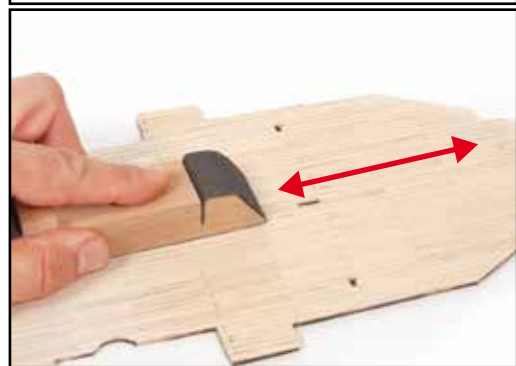
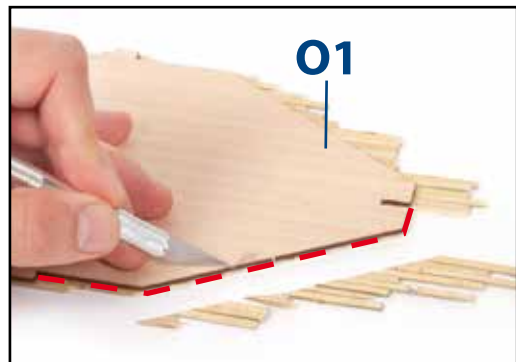
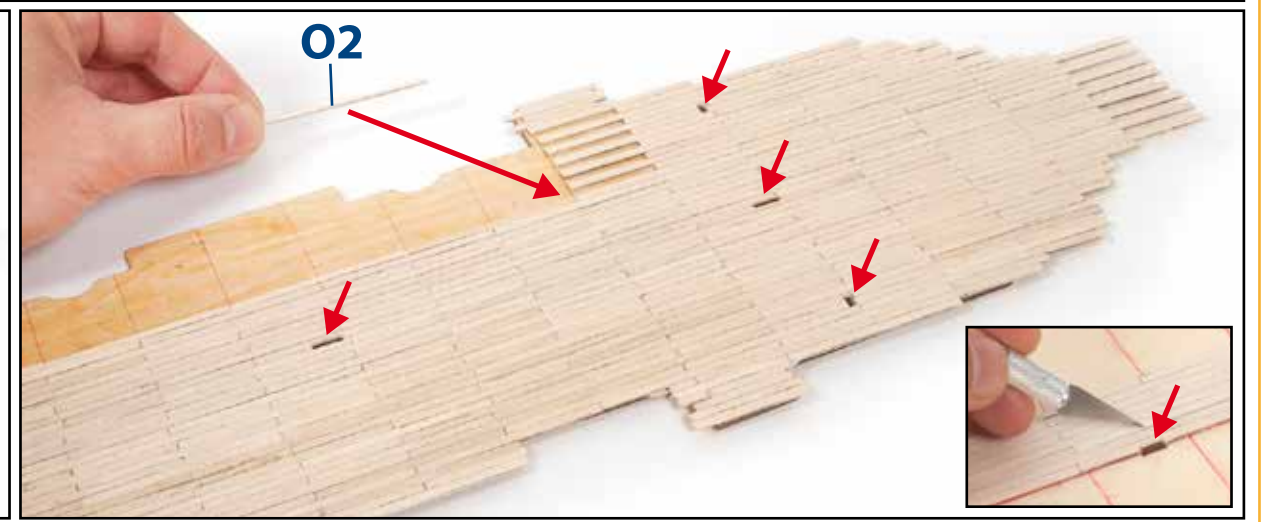
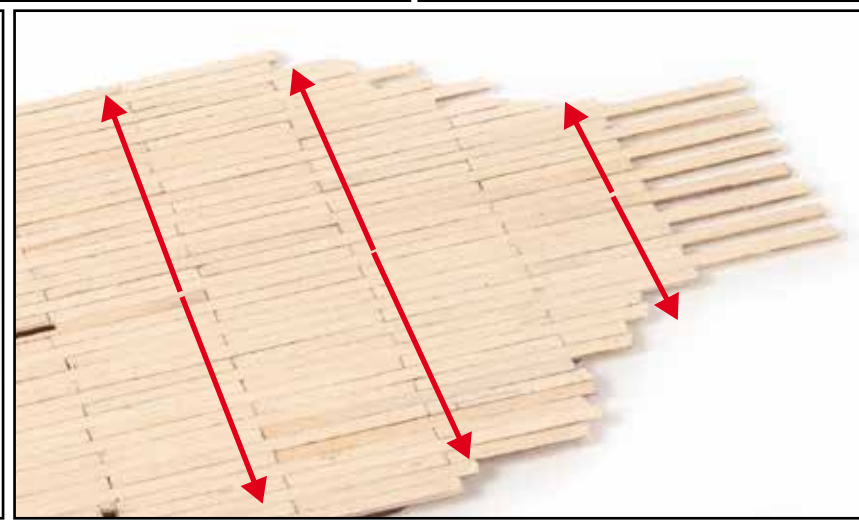
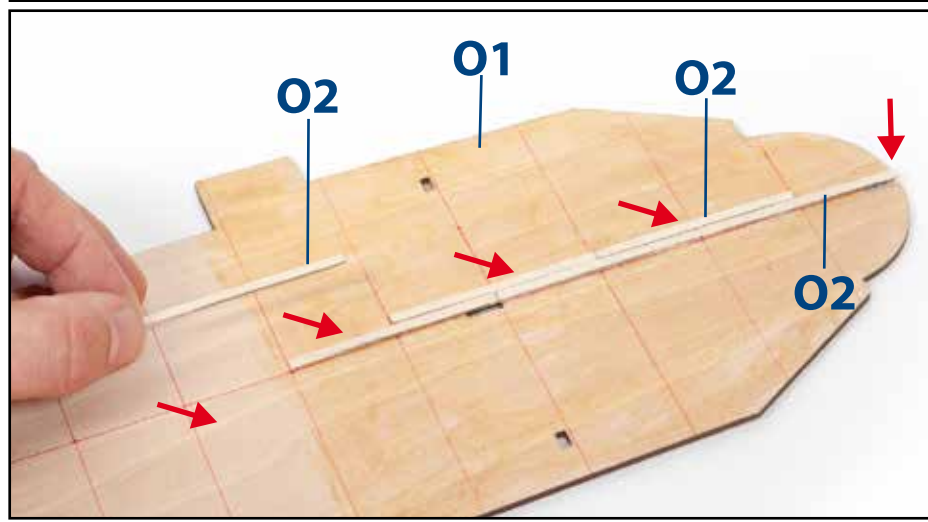
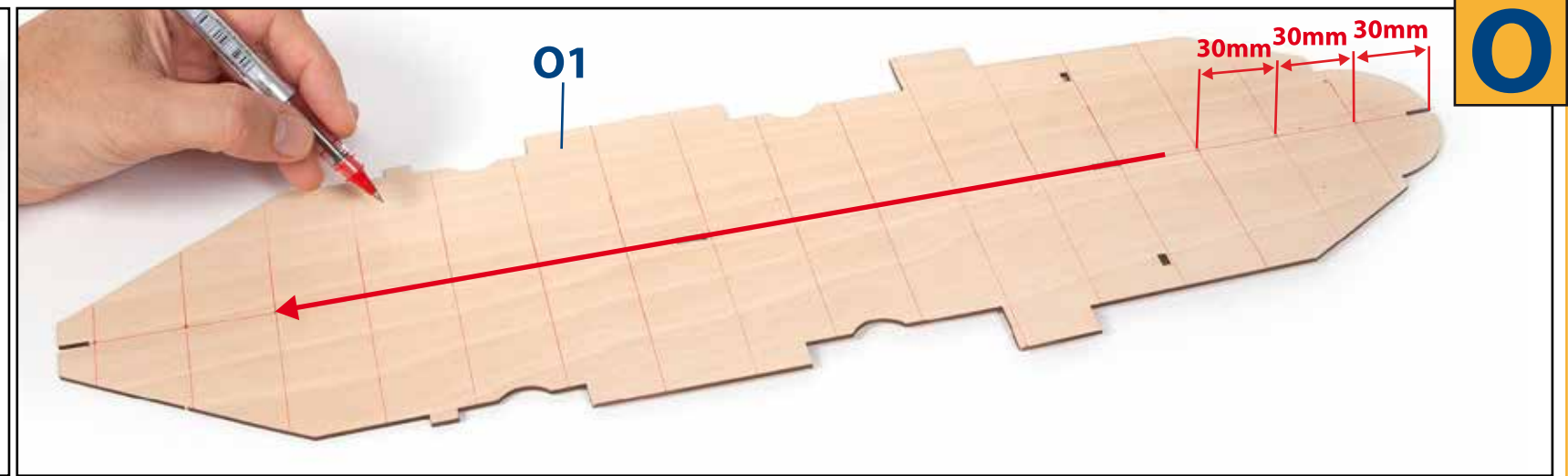
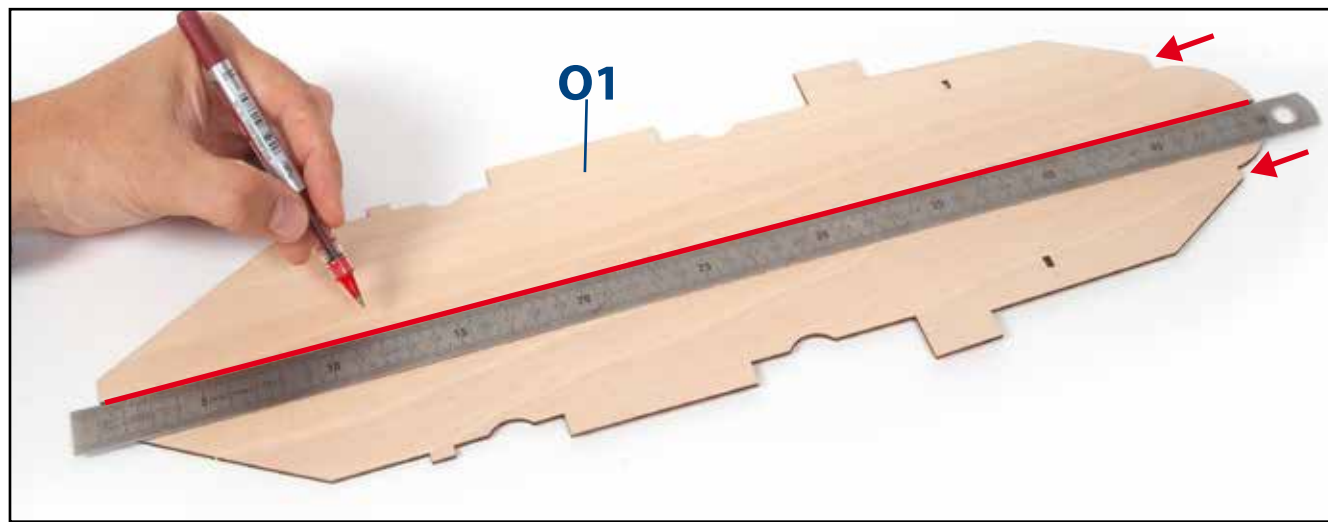

P

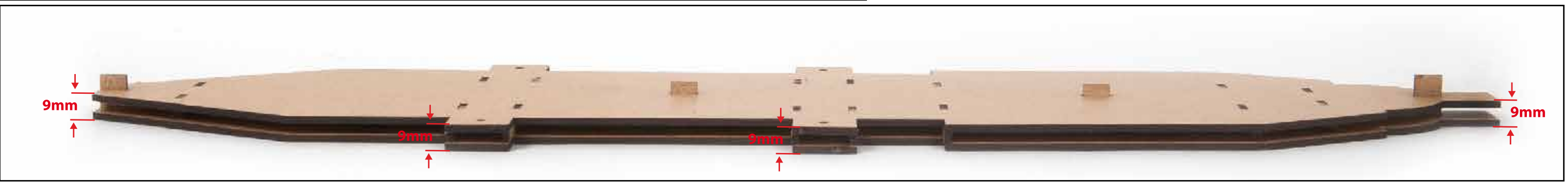
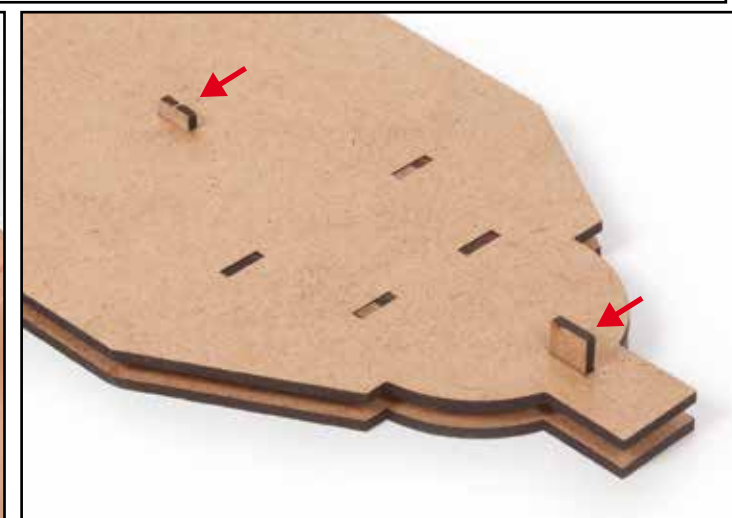
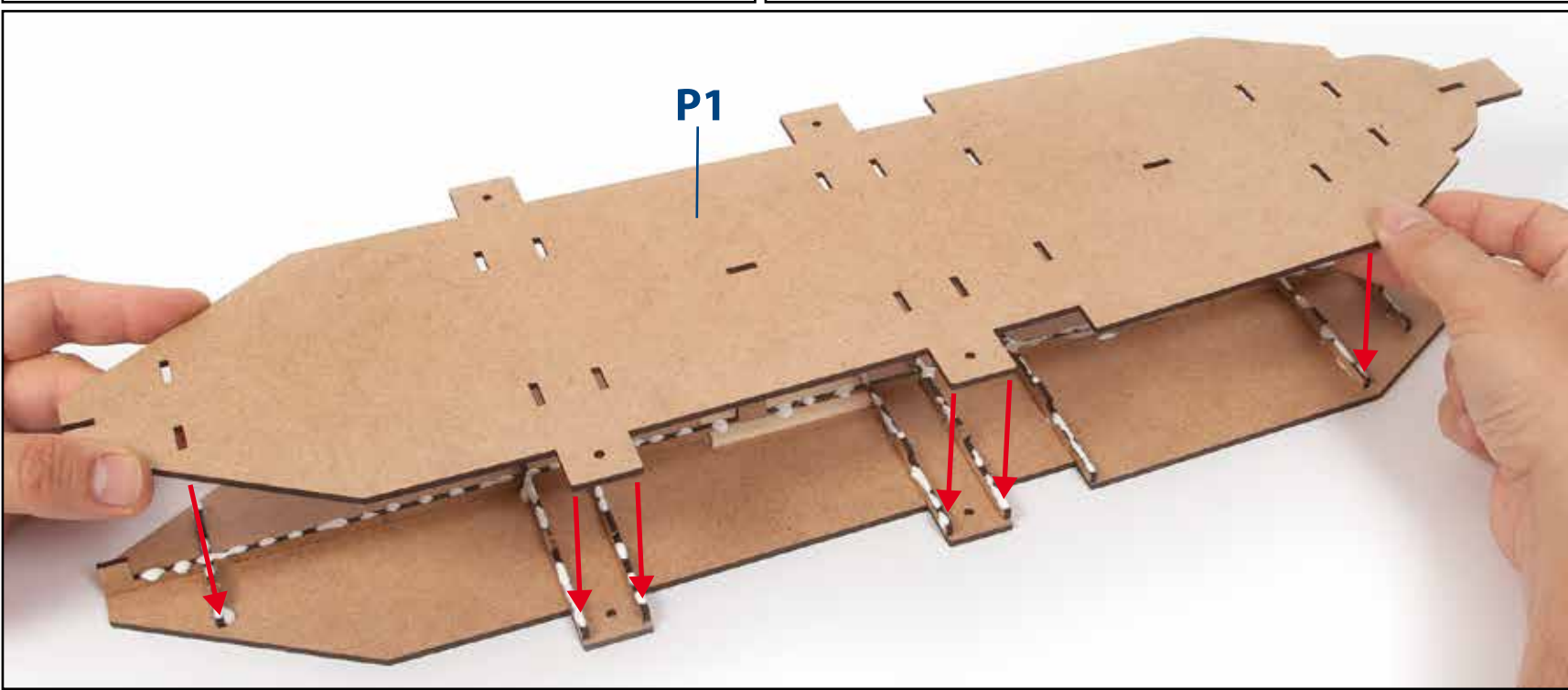
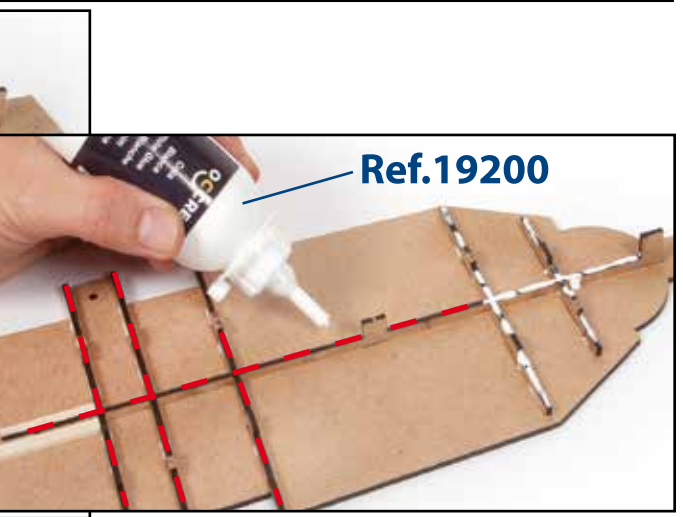
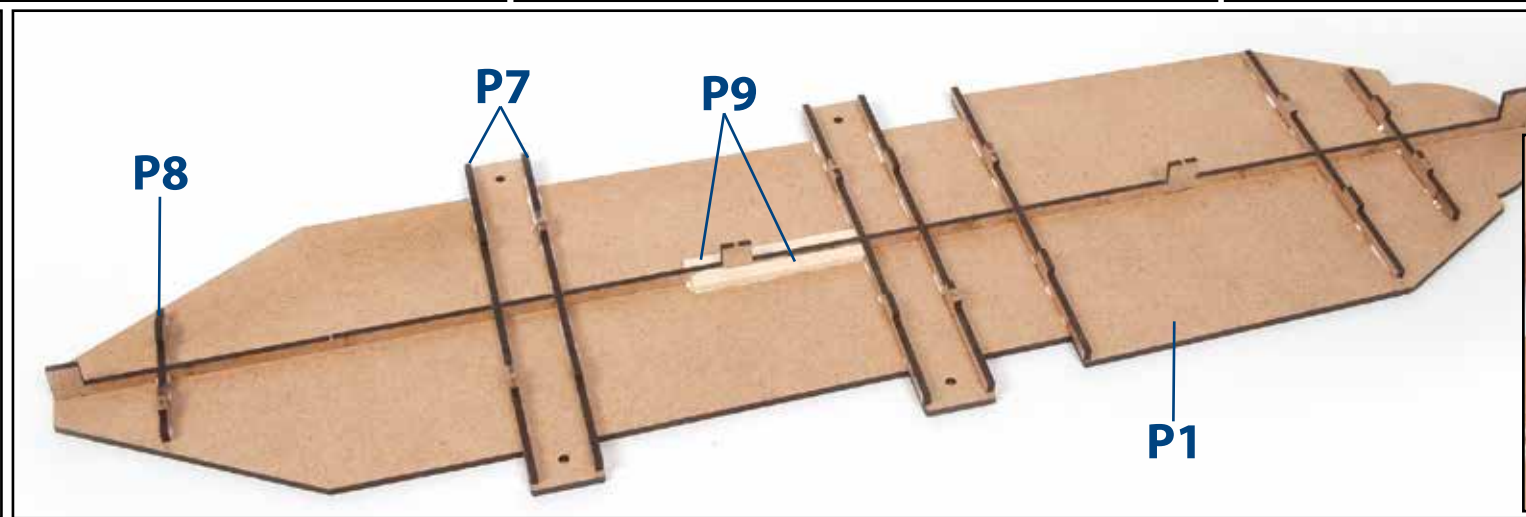
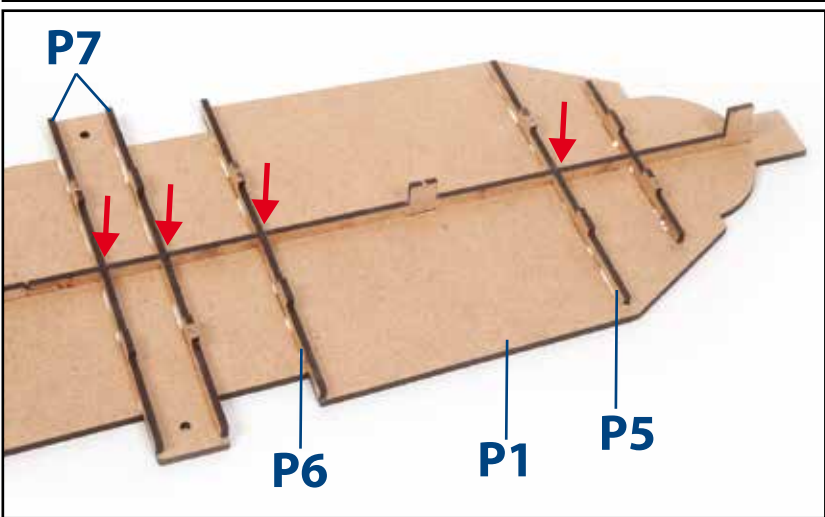
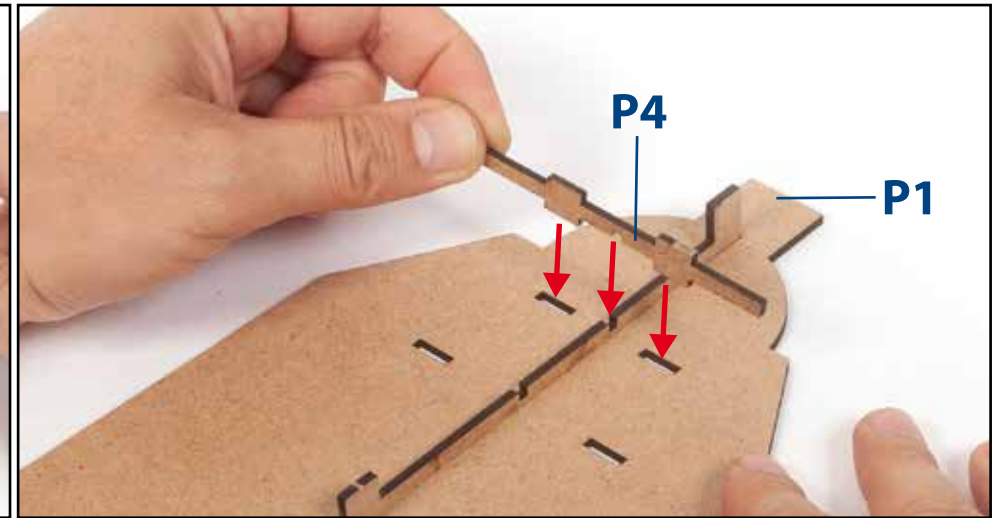
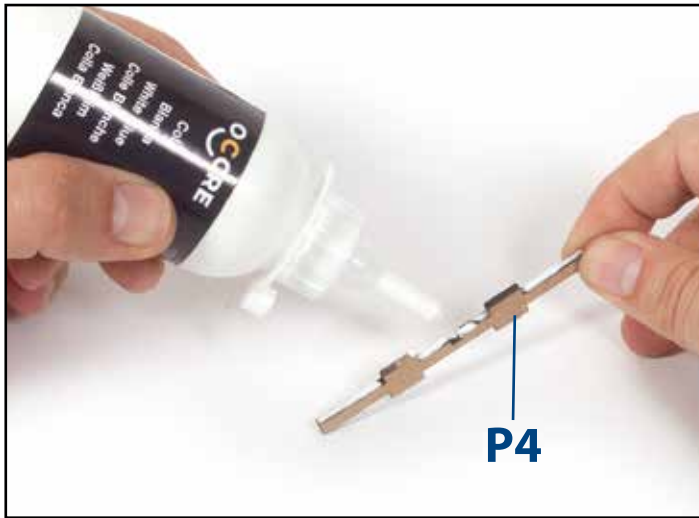
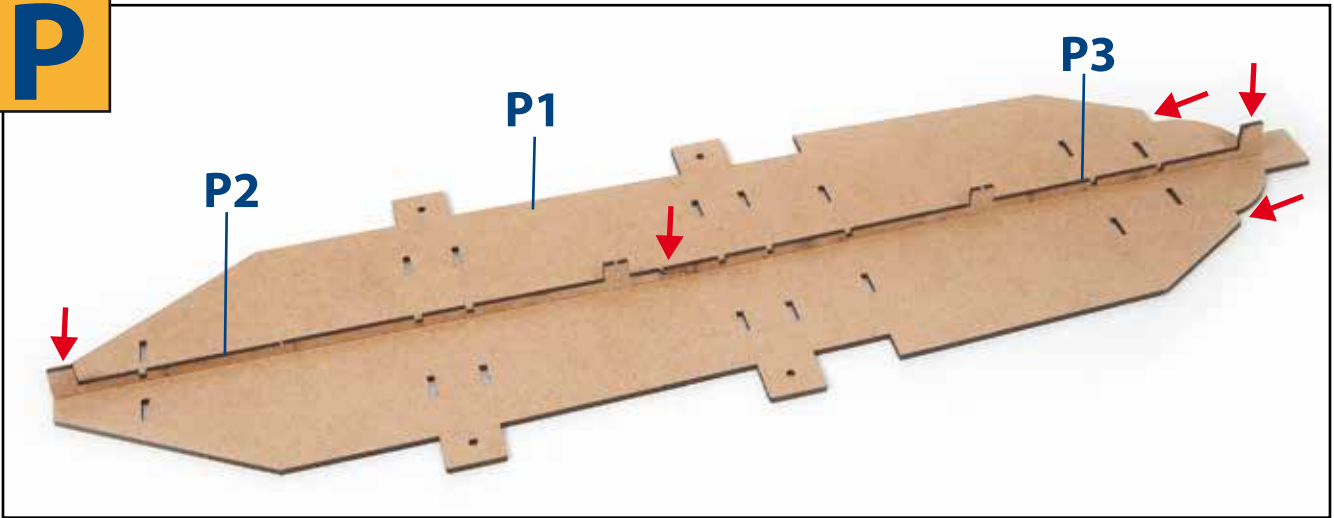

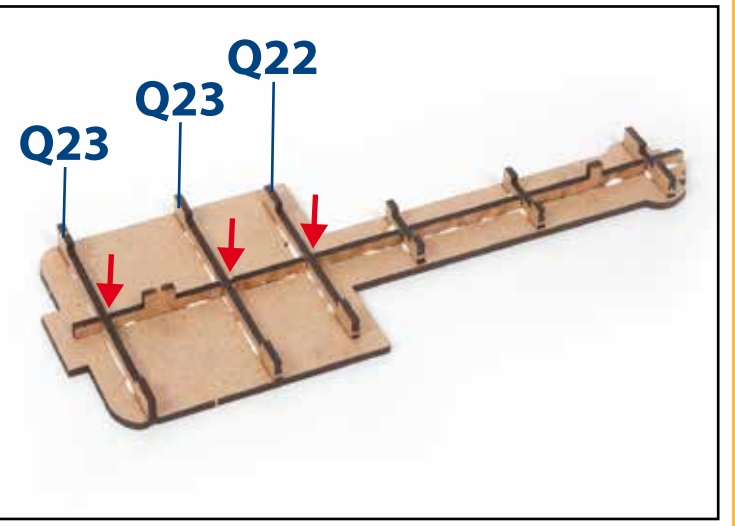
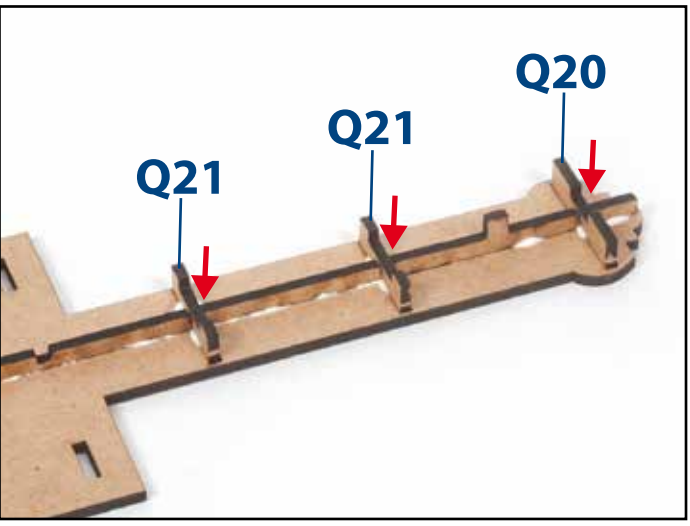
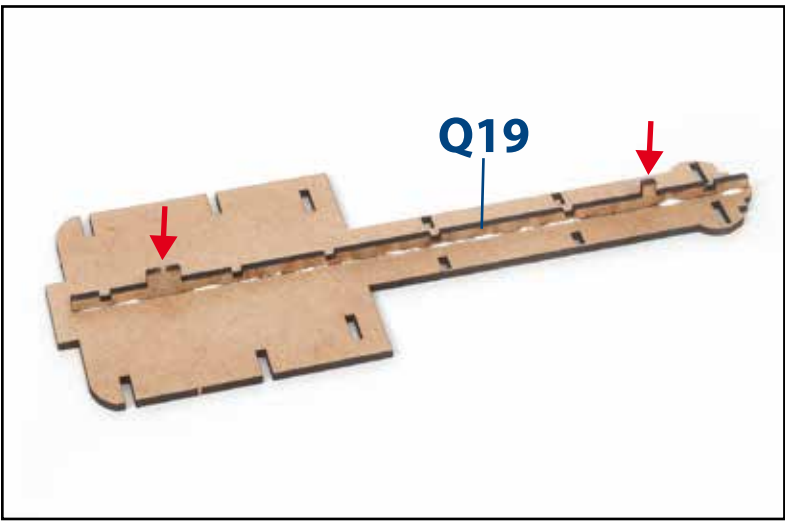
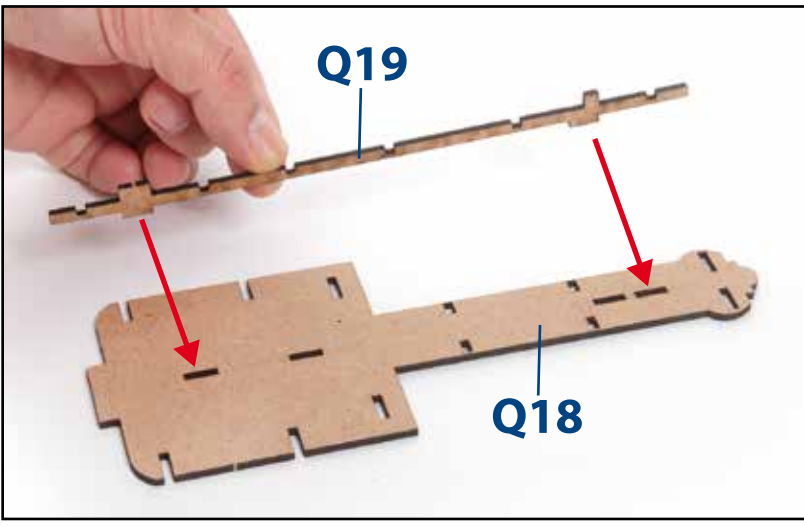
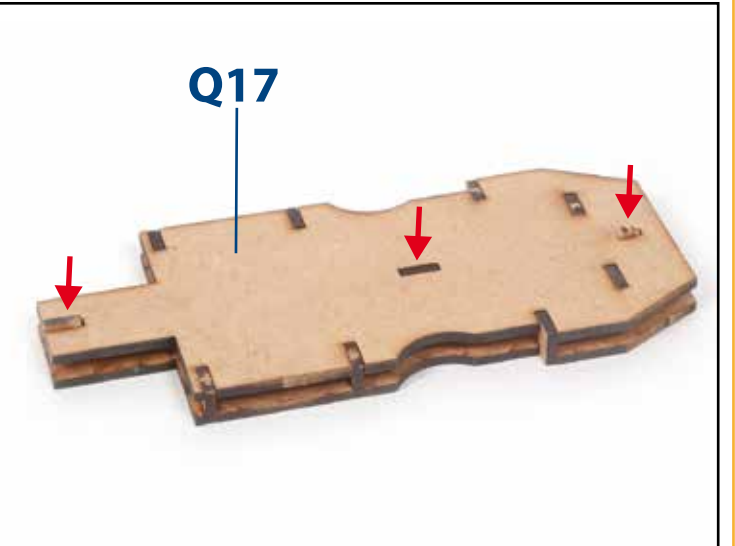
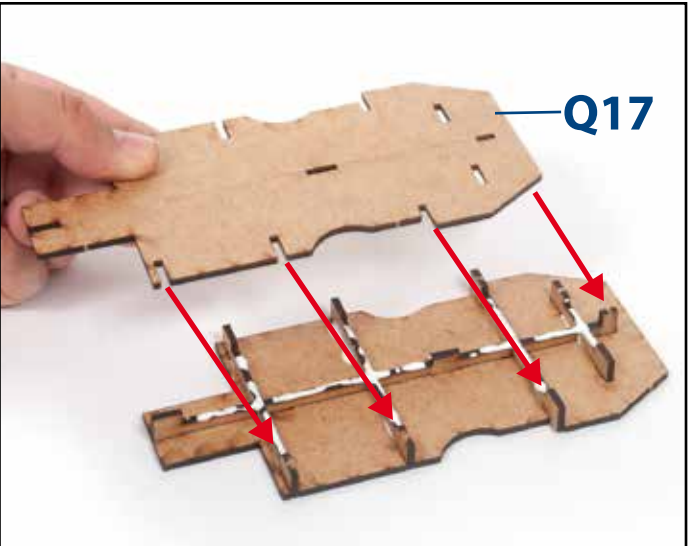
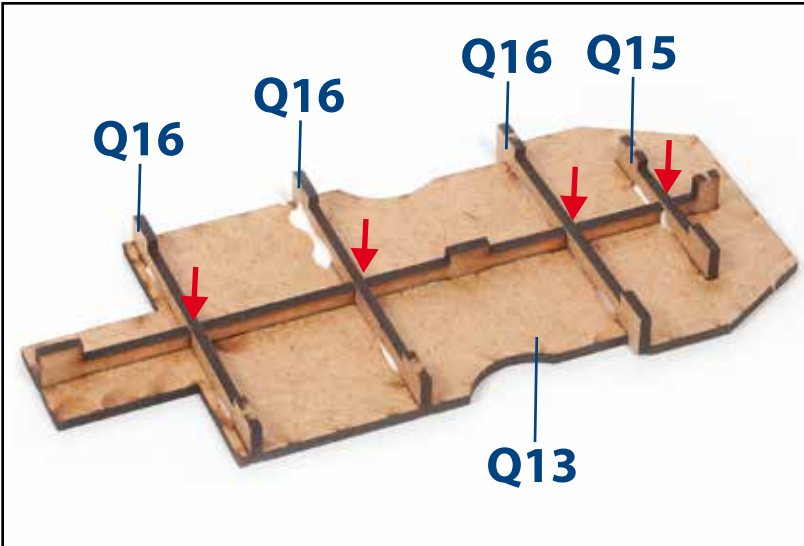
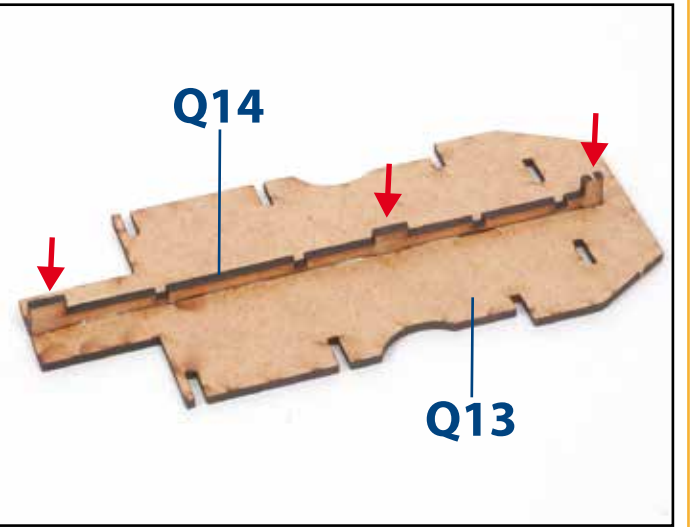
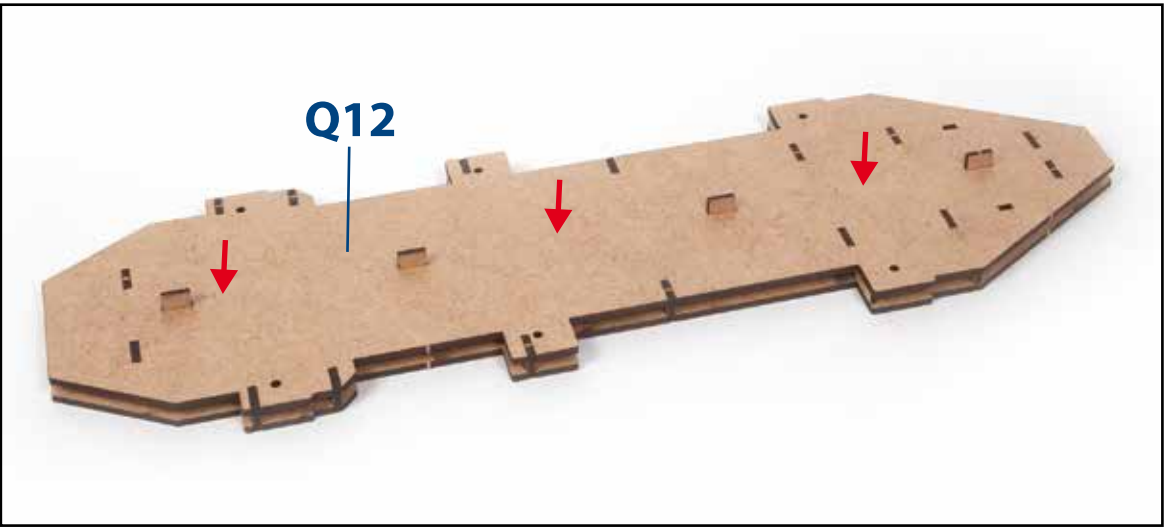
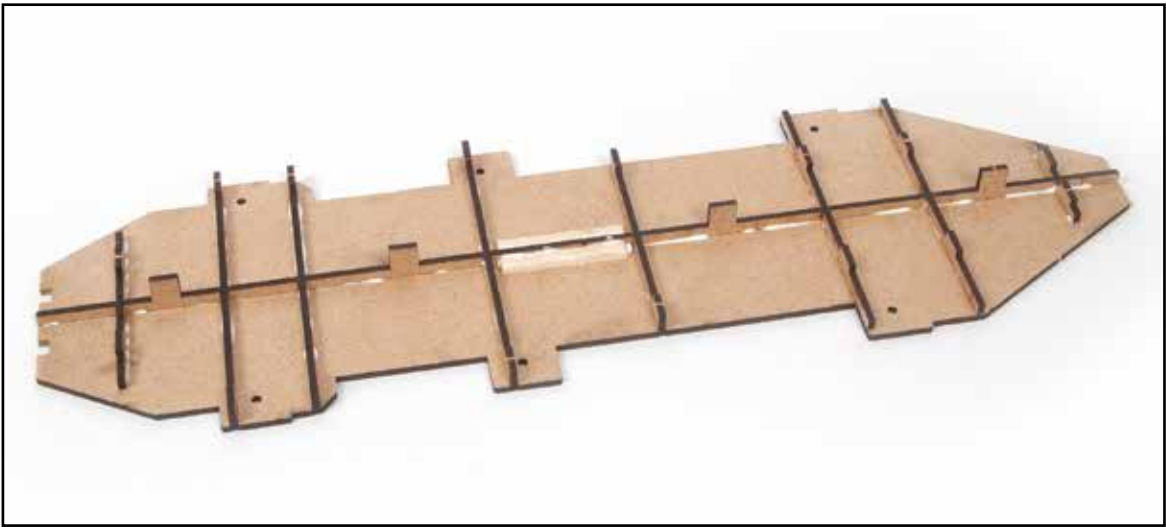
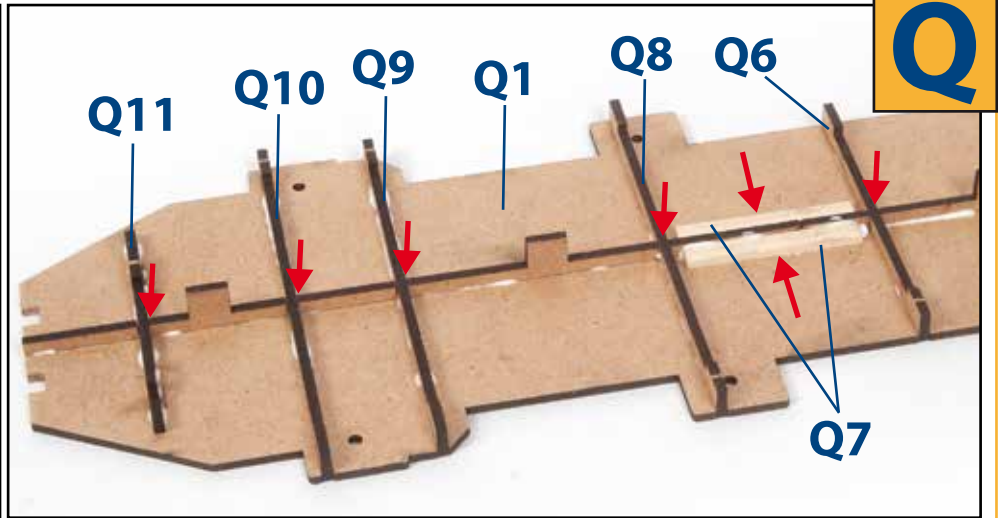
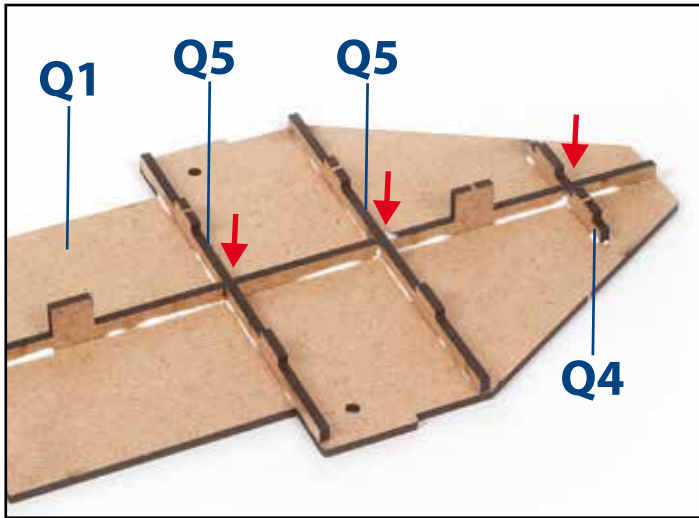
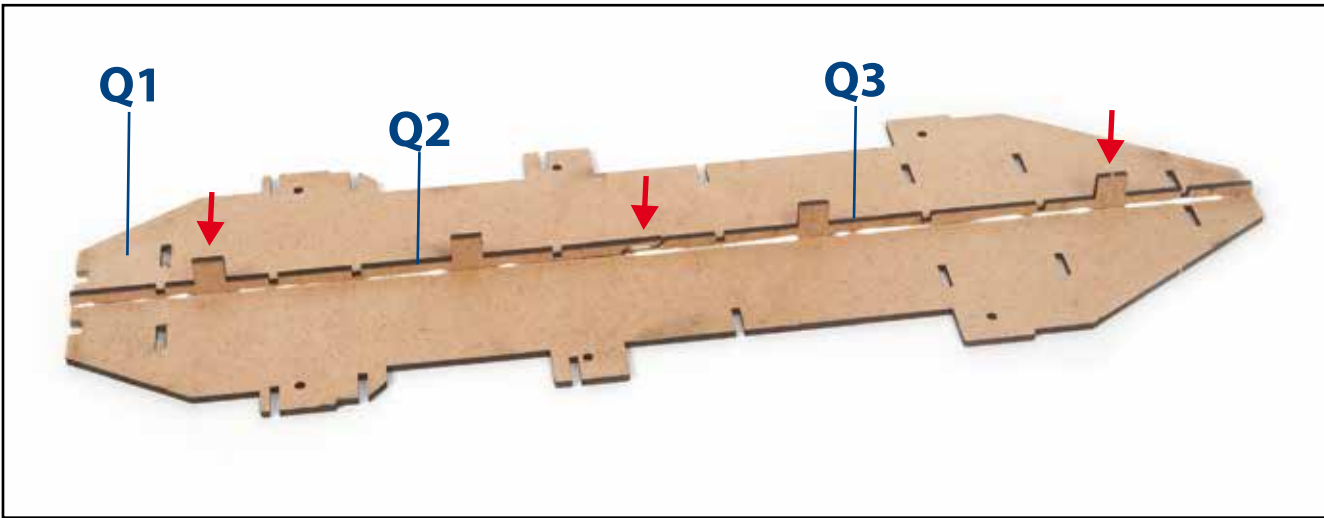

R

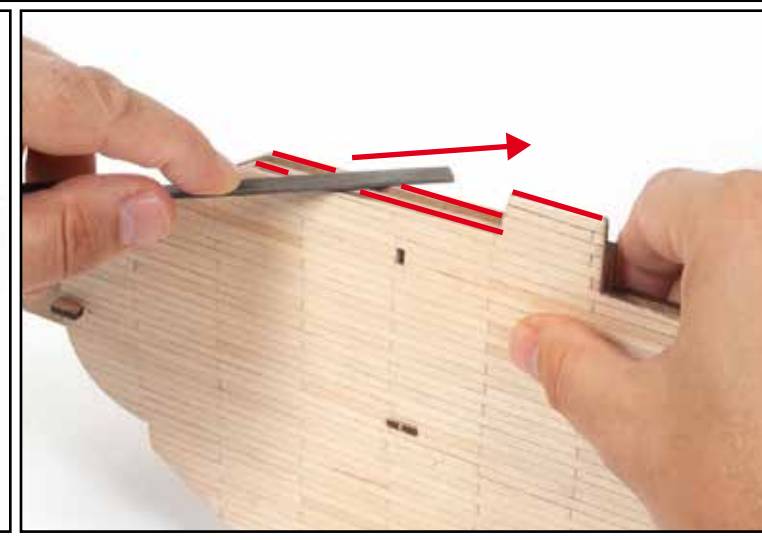
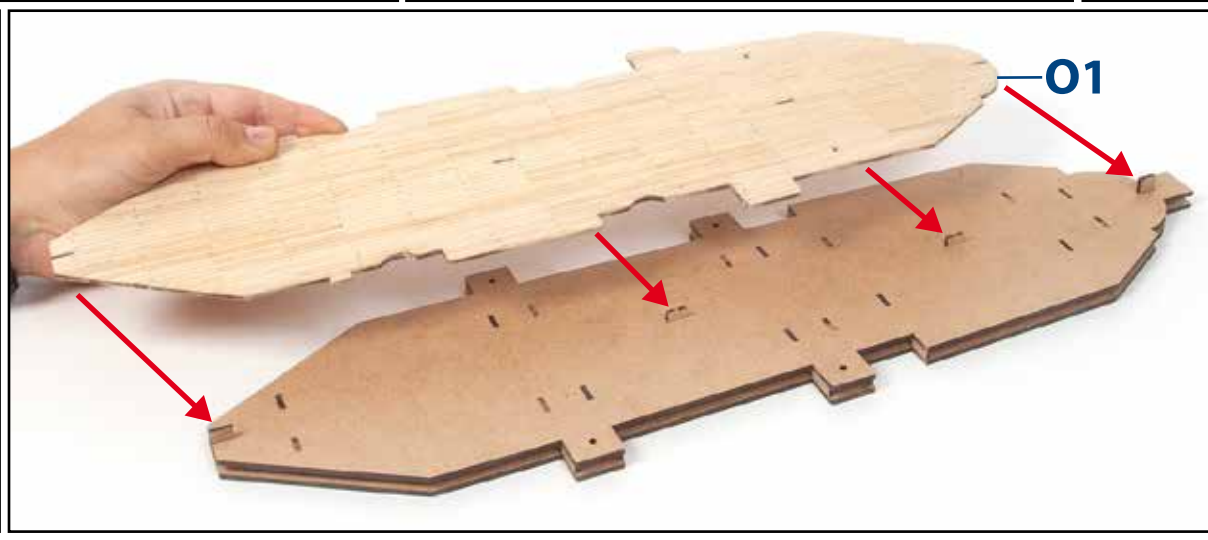
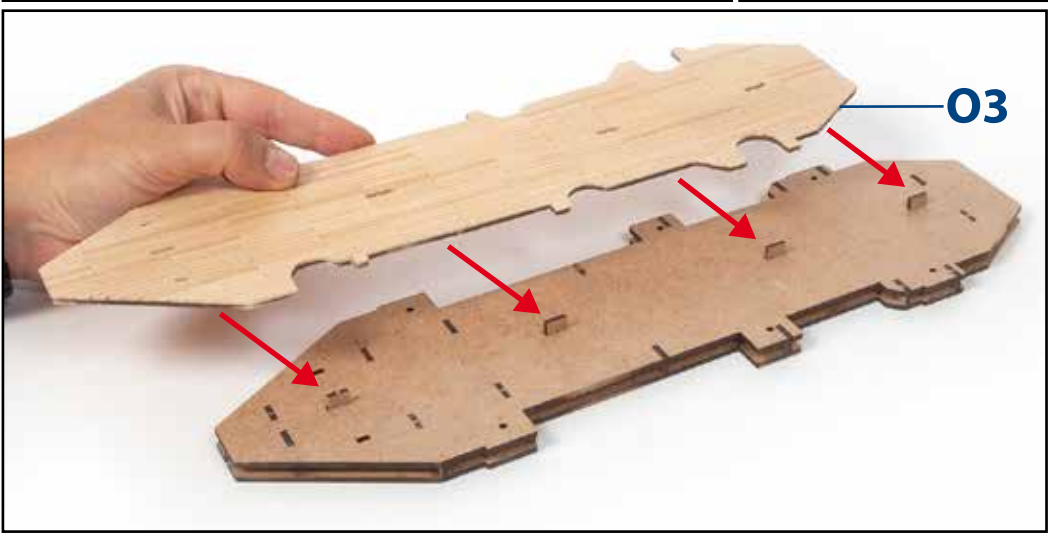
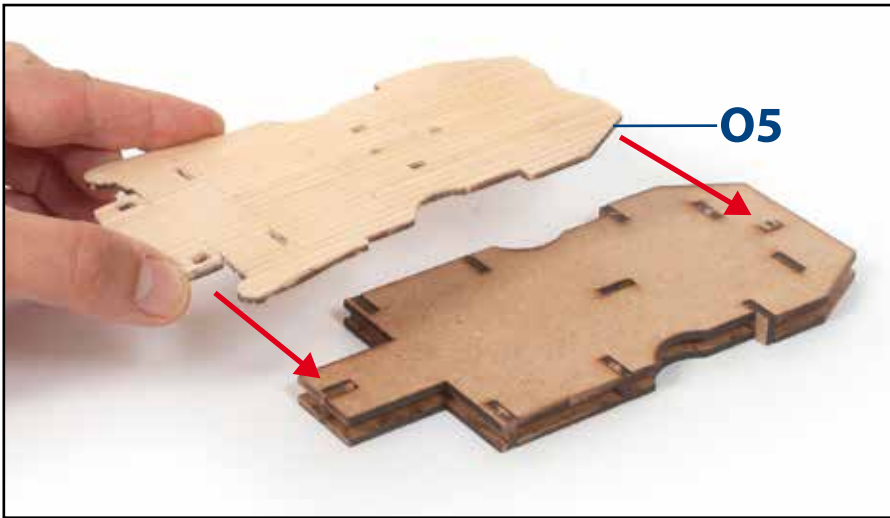
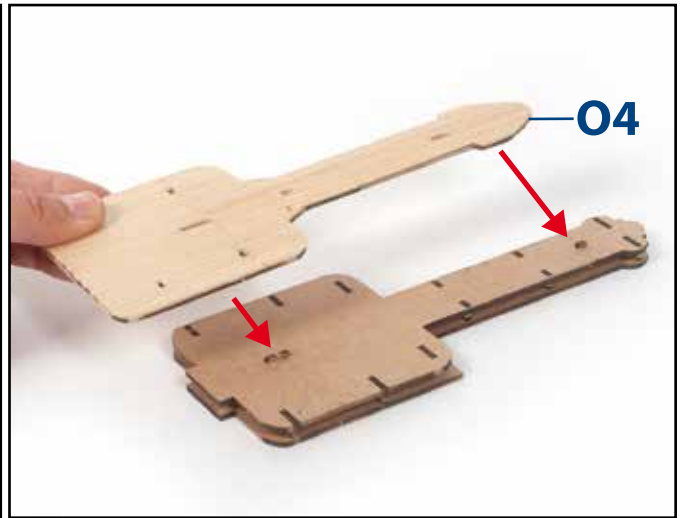
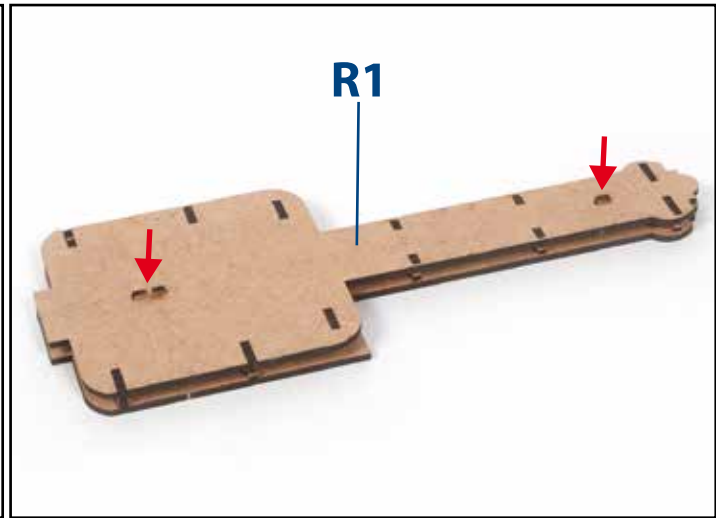
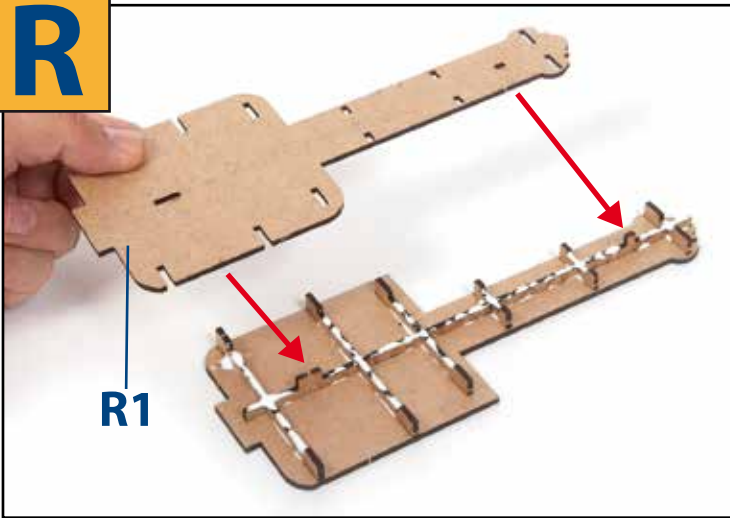

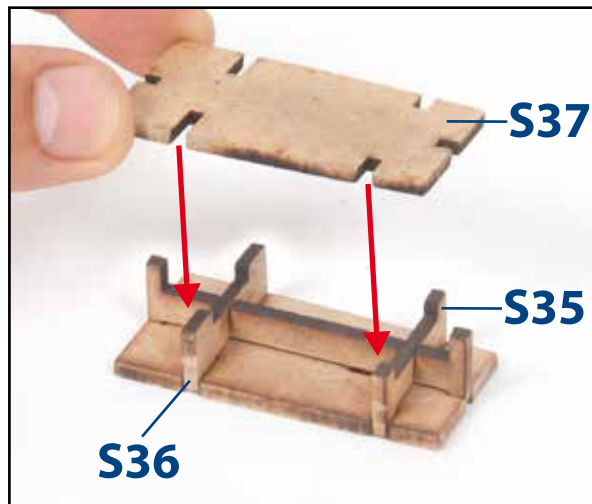
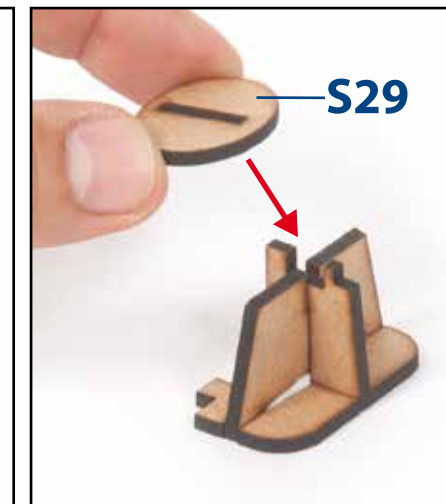
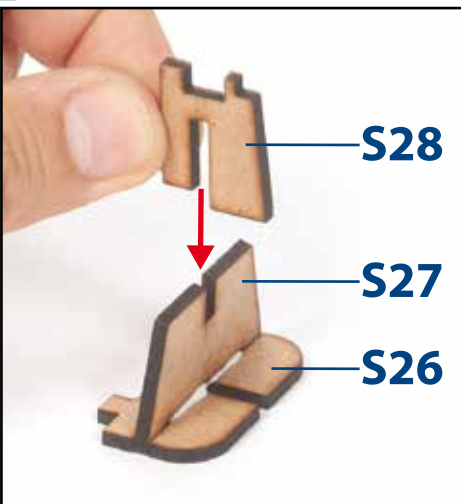
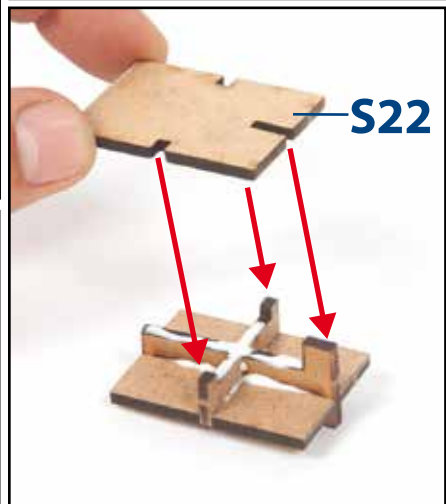
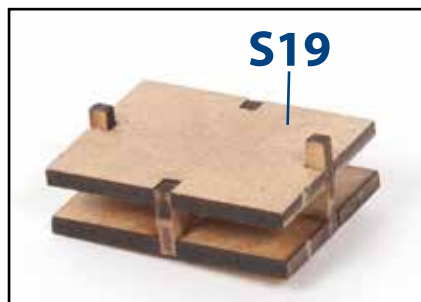
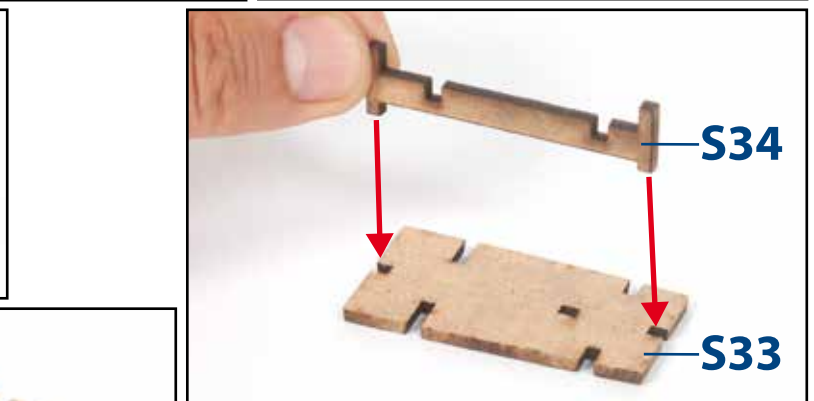
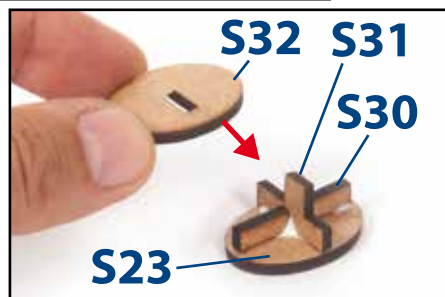
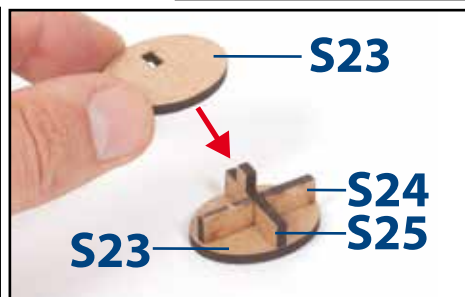
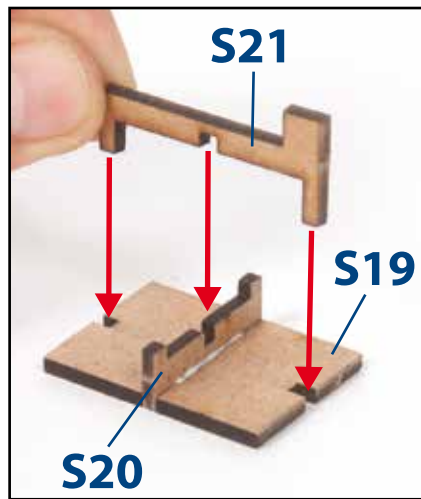
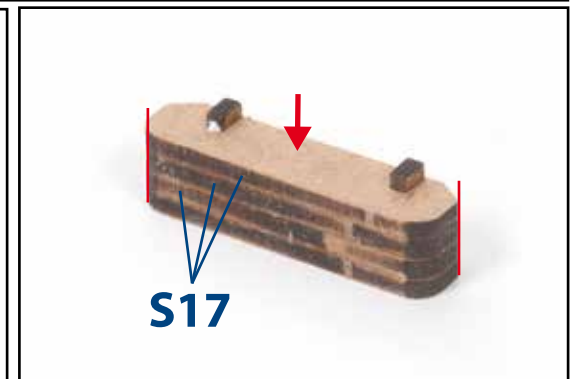
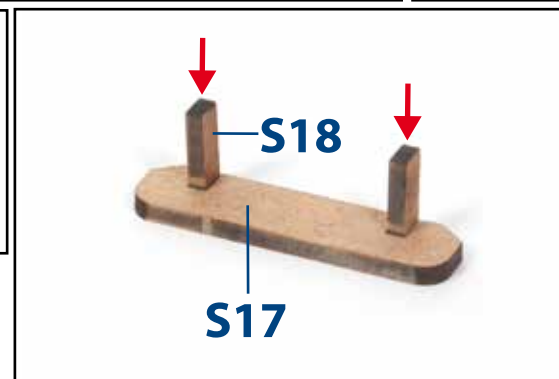
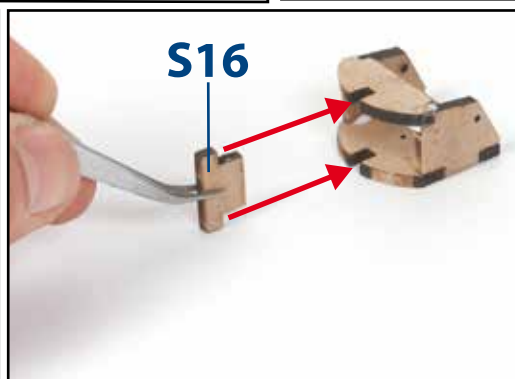
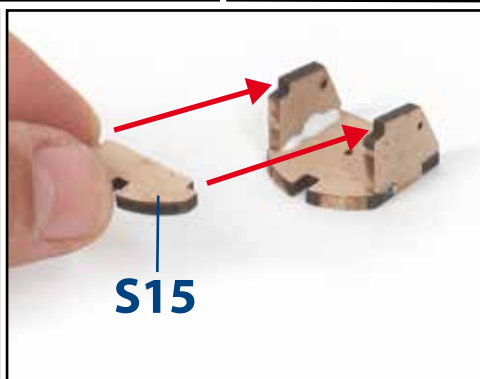
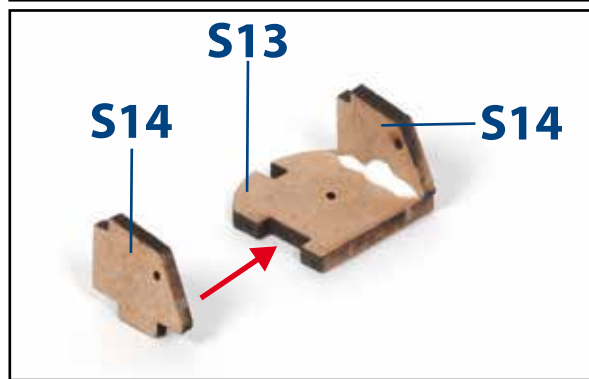
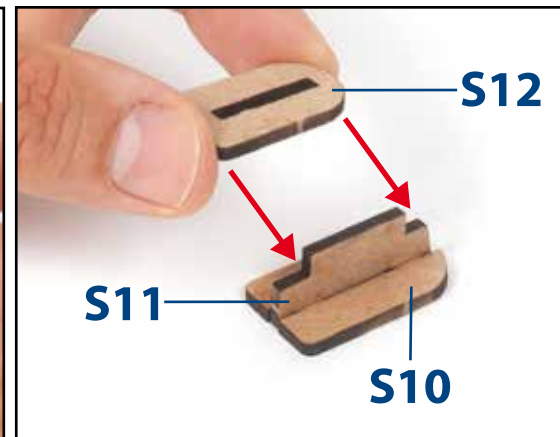
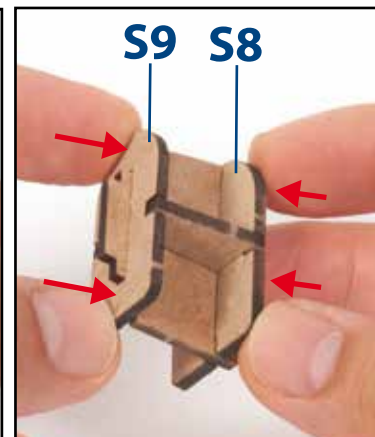
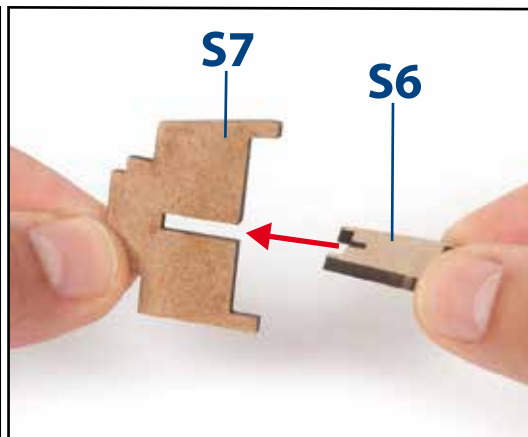
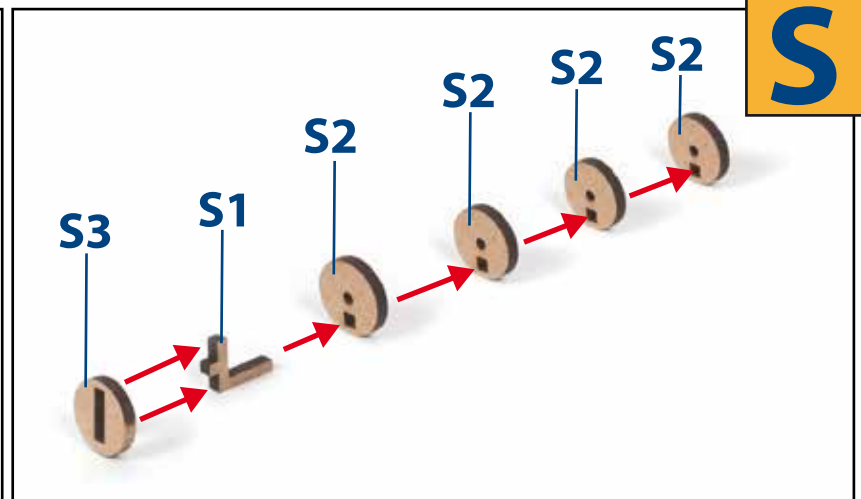
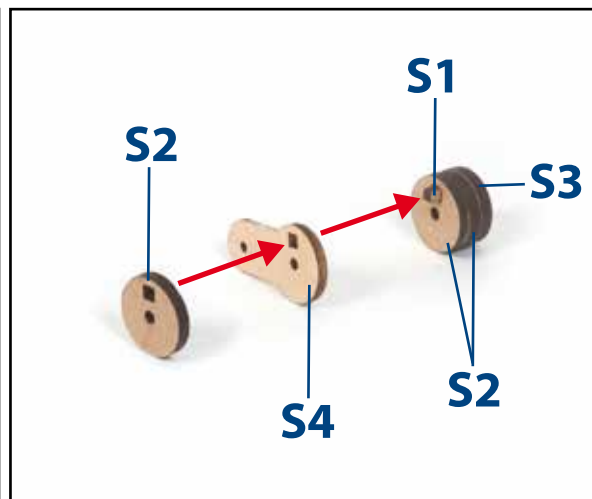
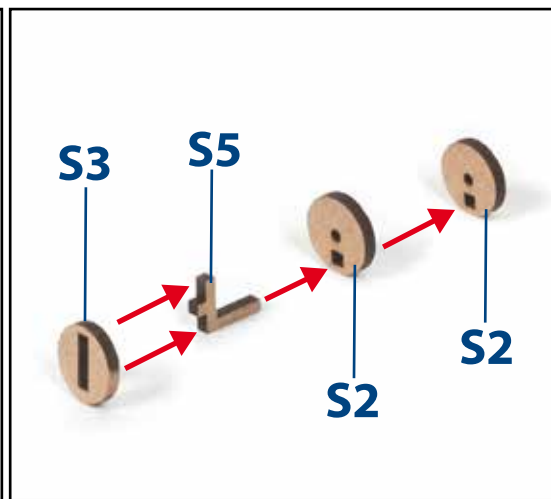
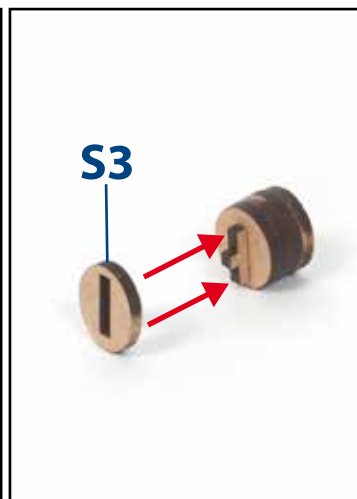
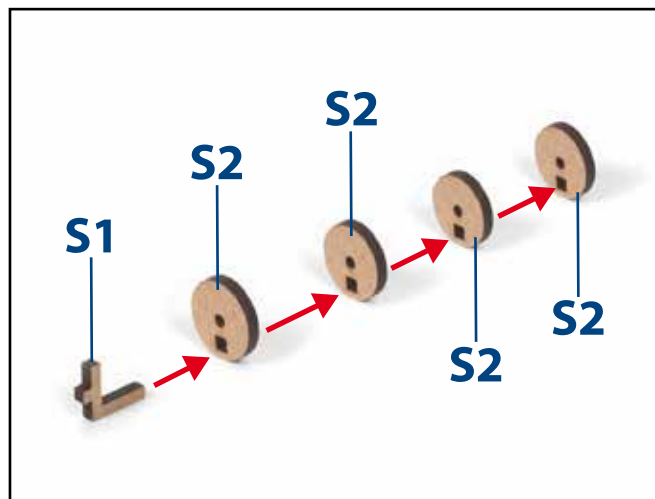

T

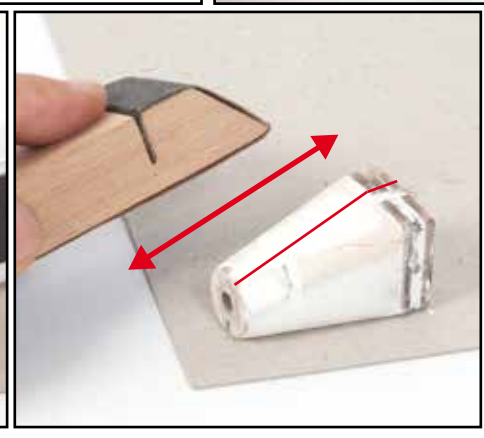
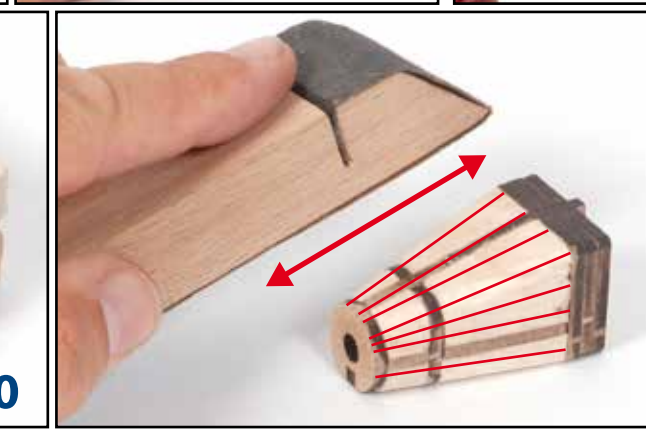
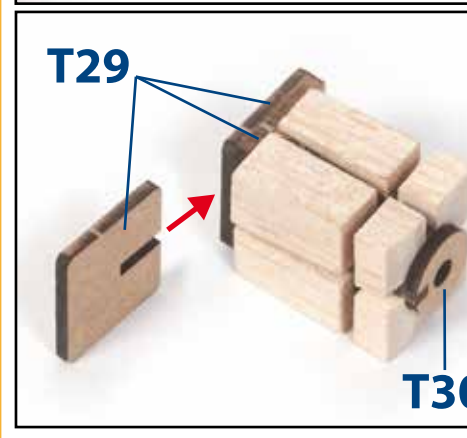
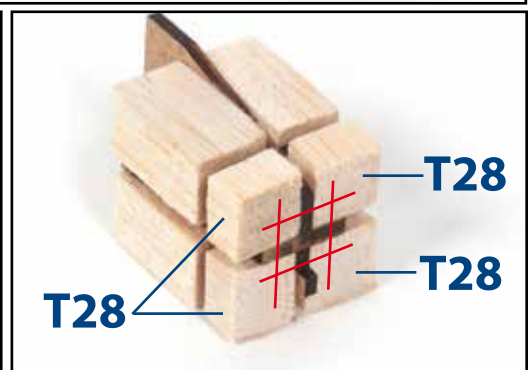
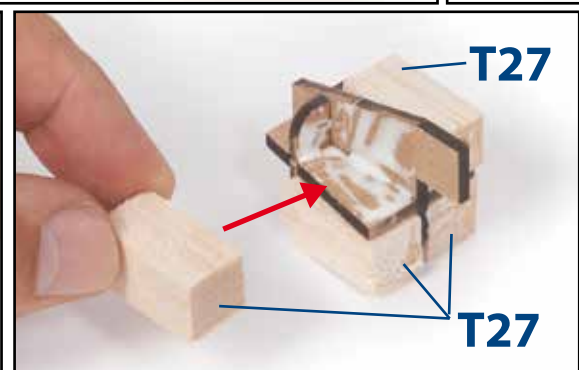
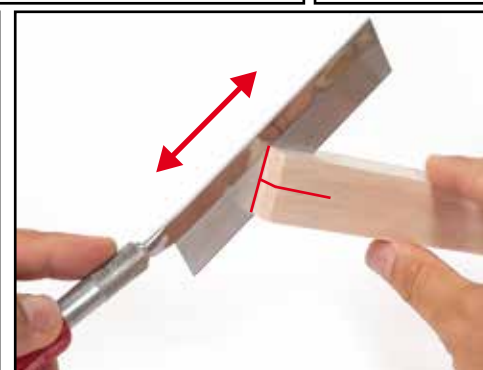
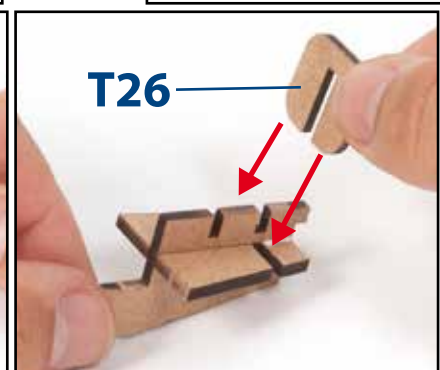
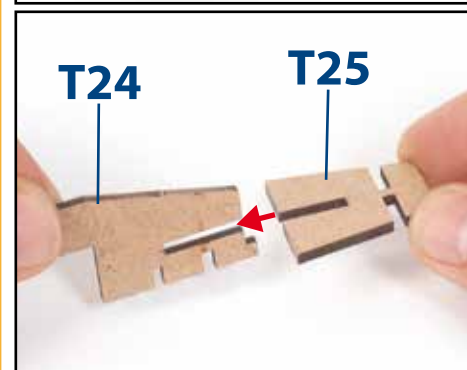
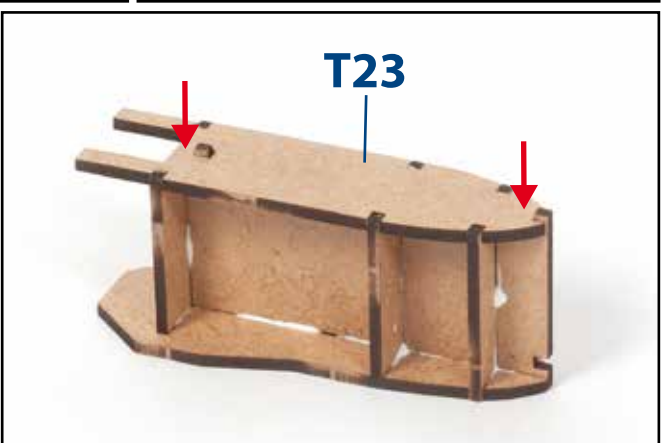
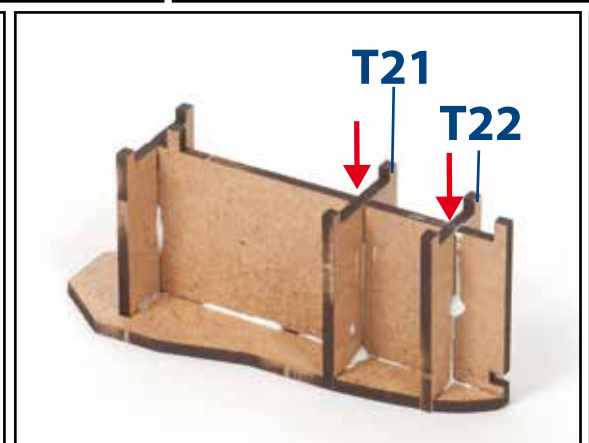
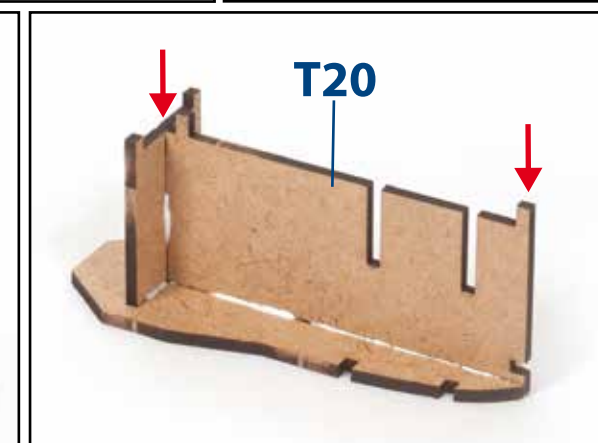
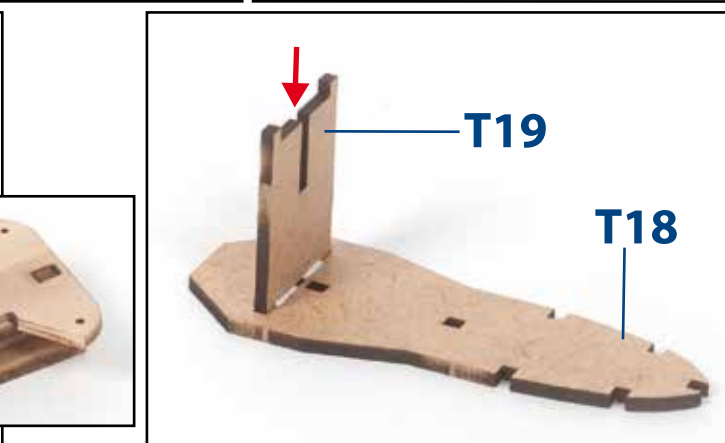
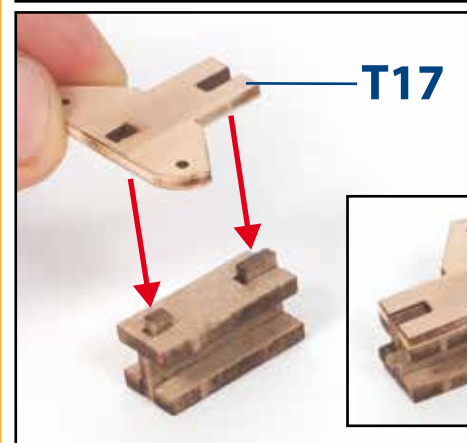
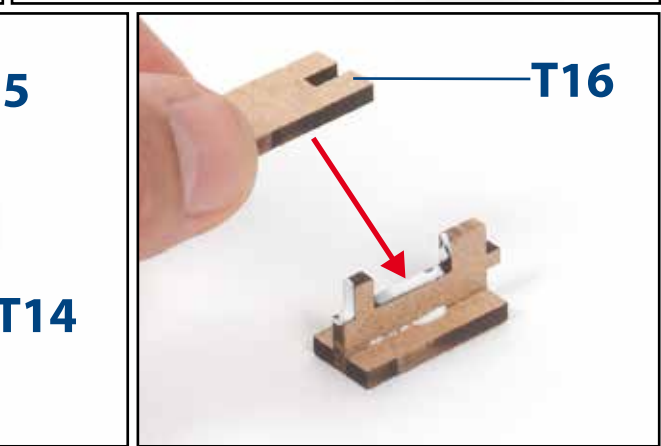
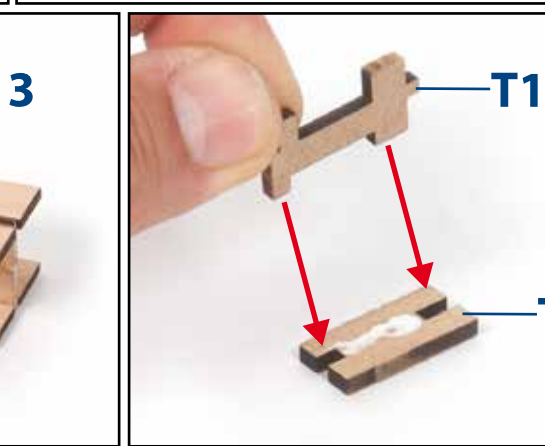
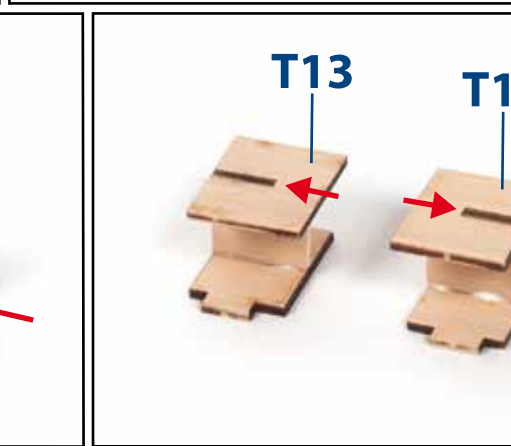
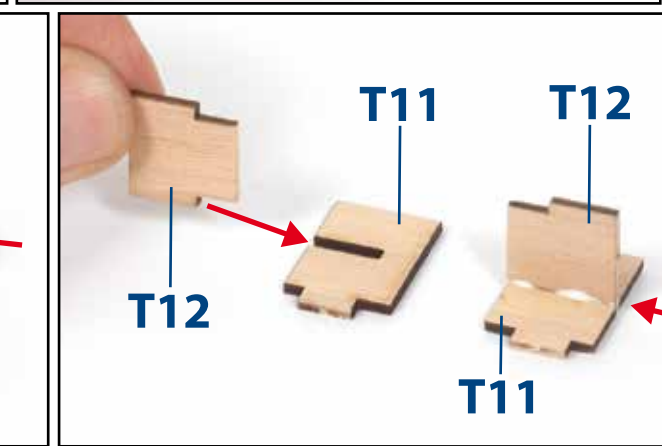
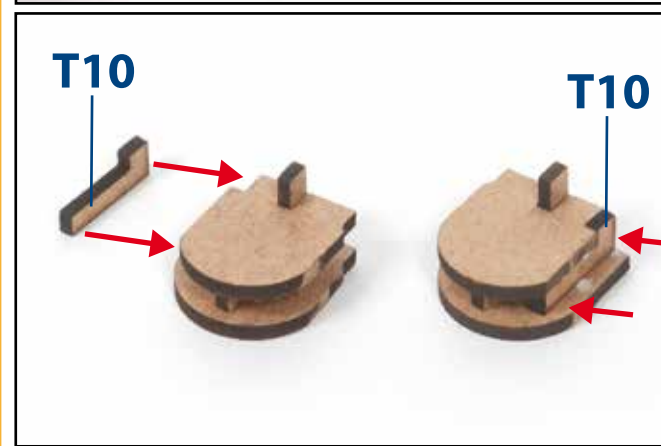
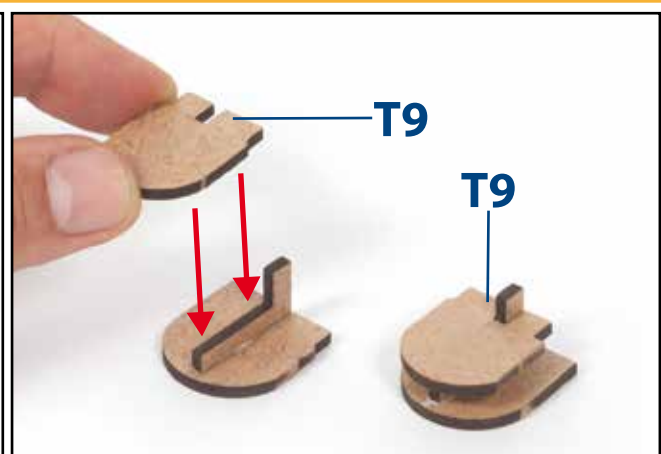
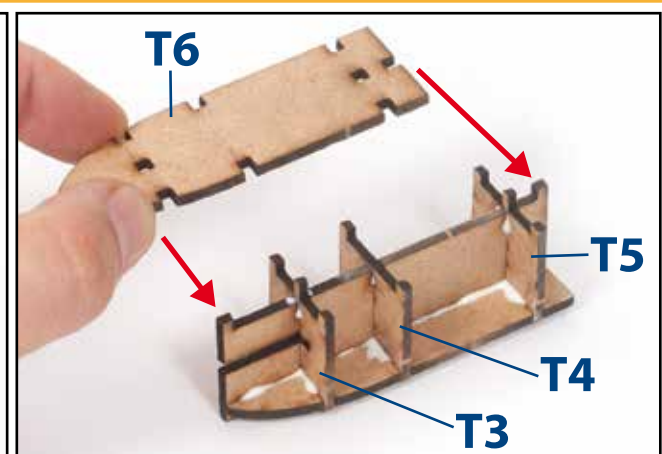
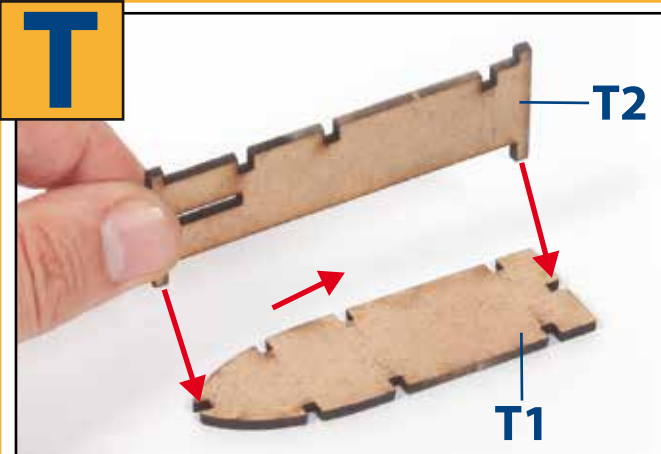

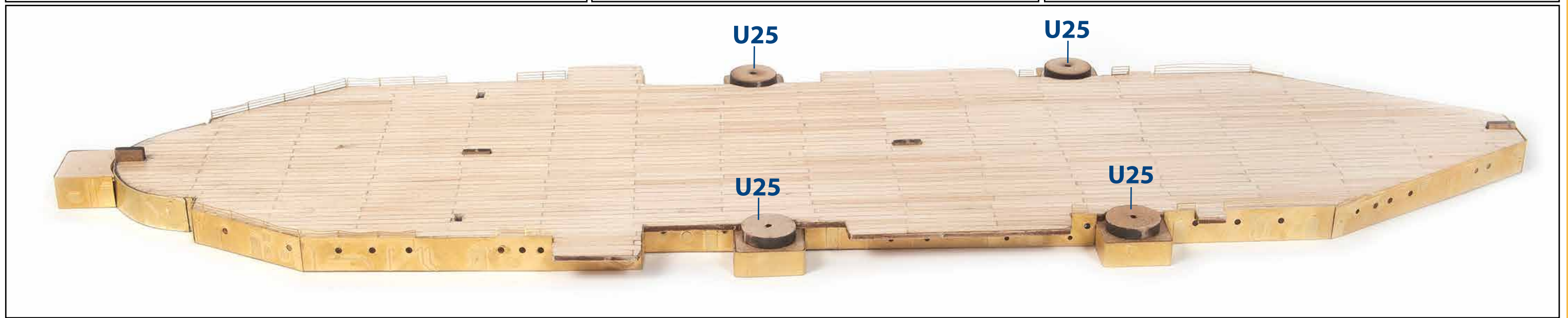
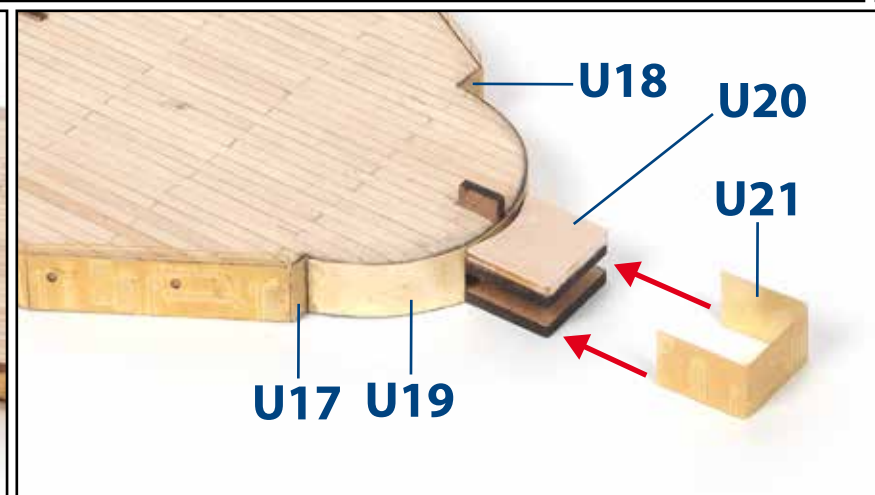
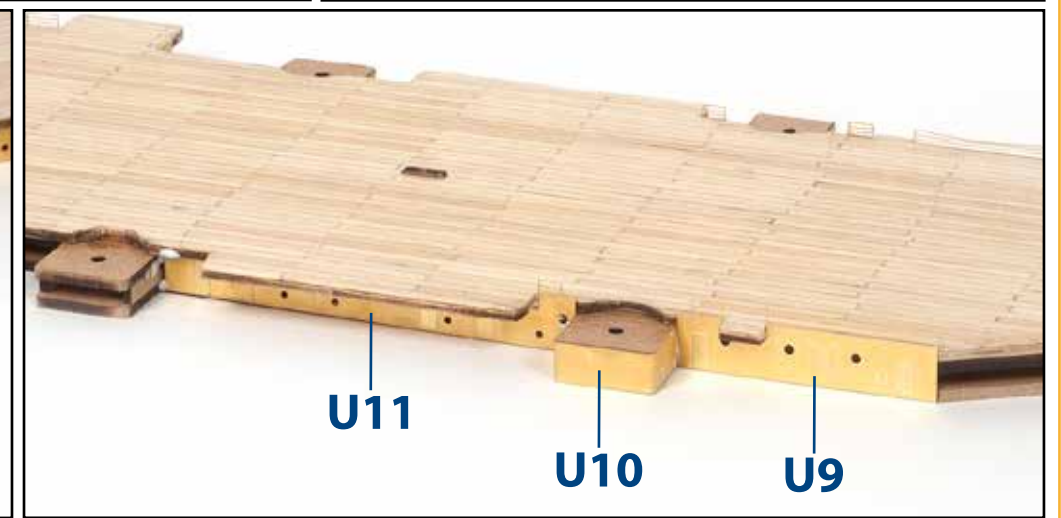
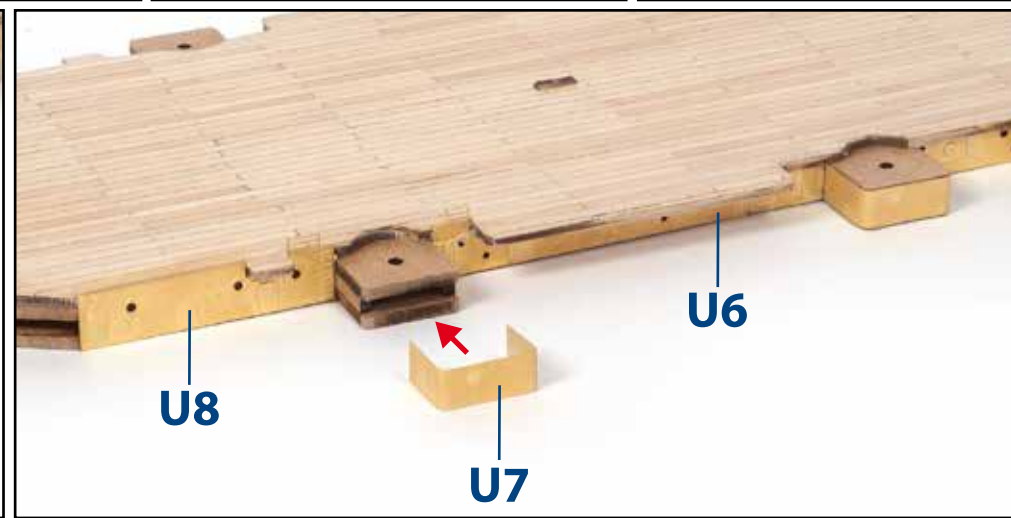
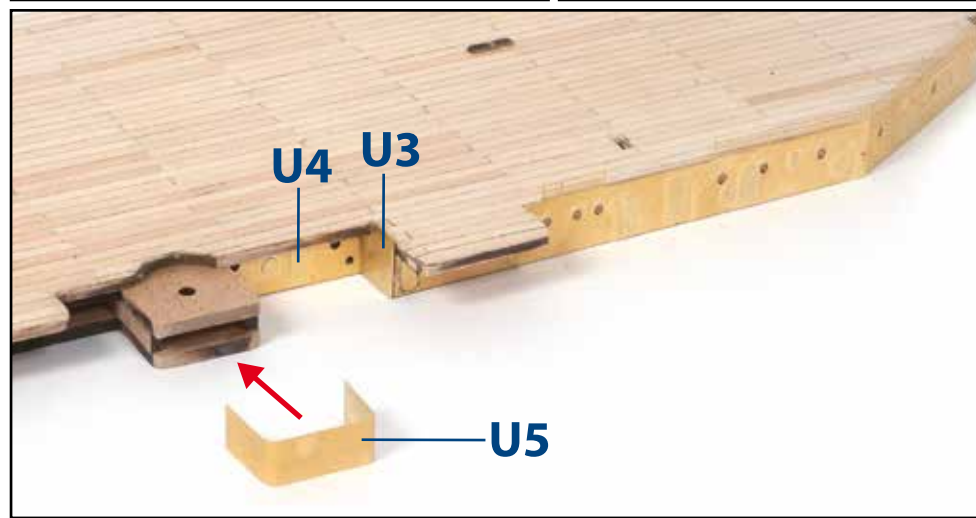
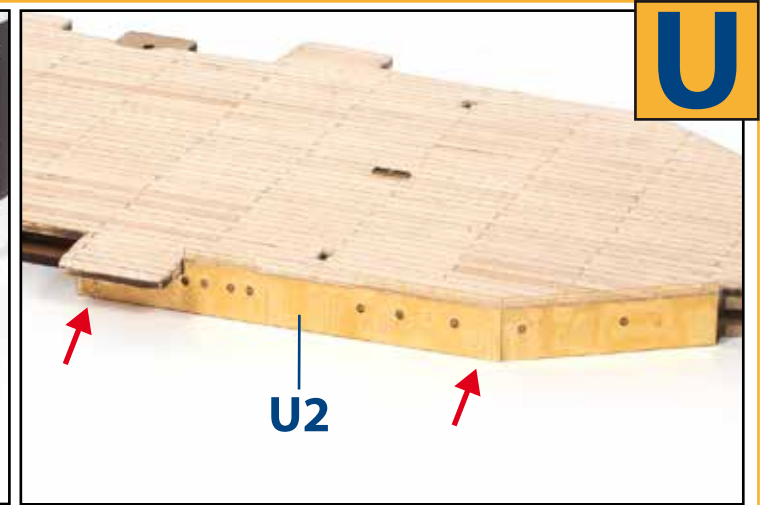
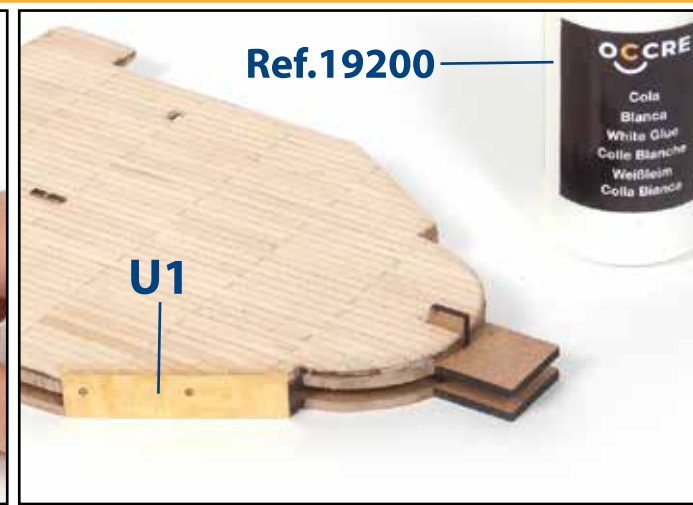
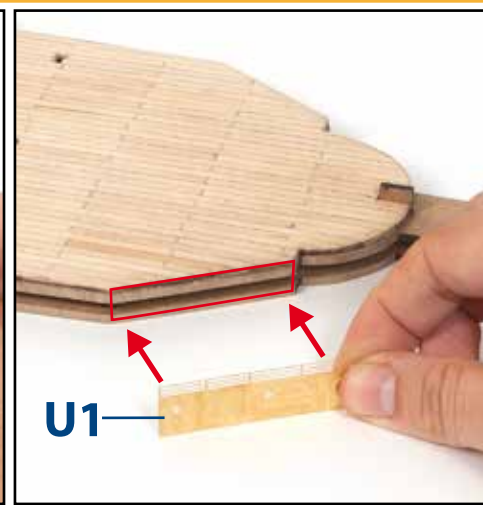
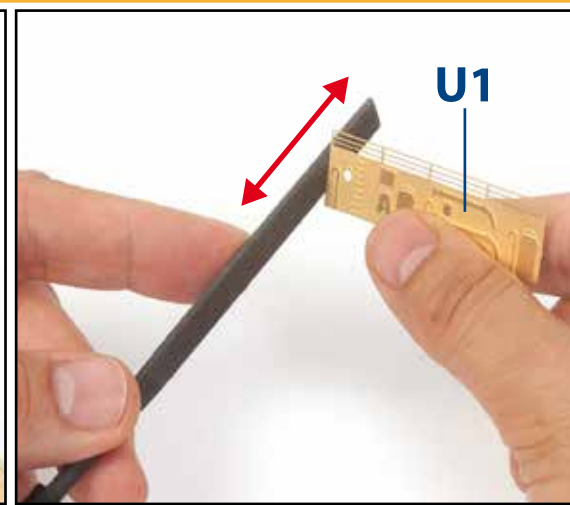
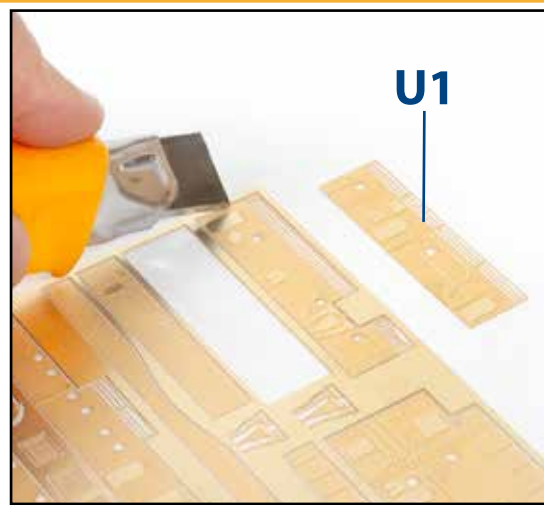

U

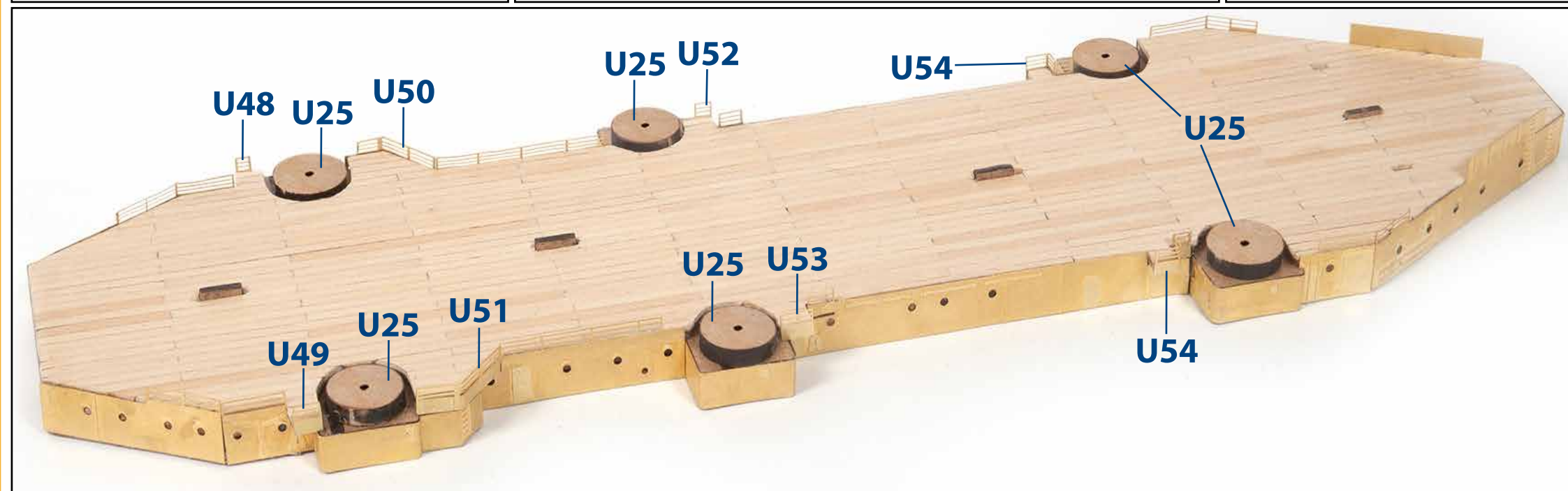
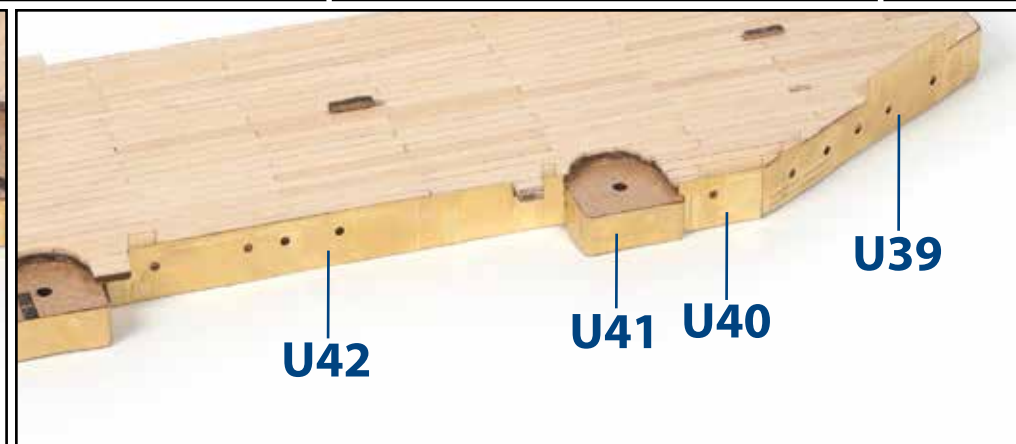

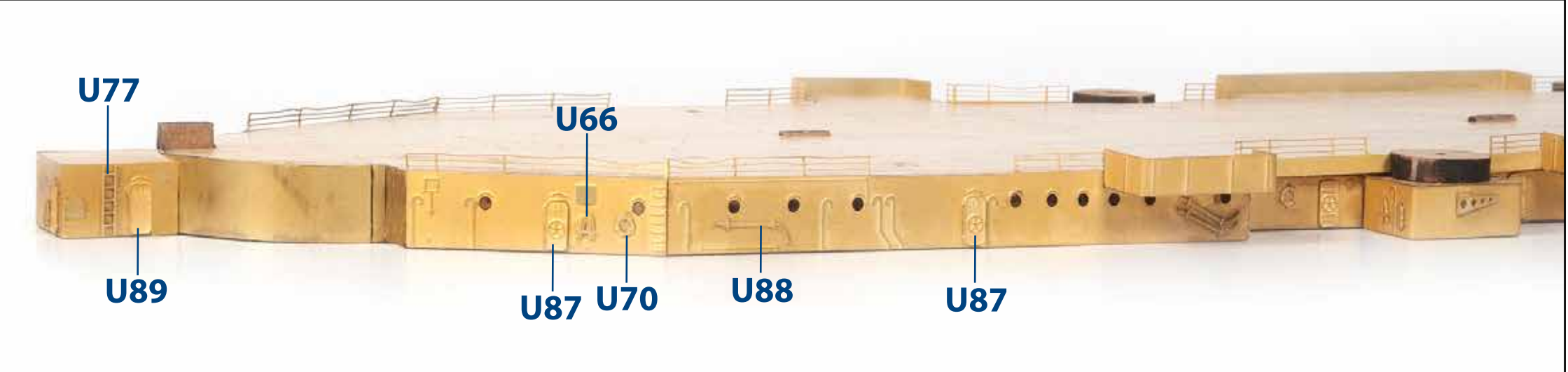
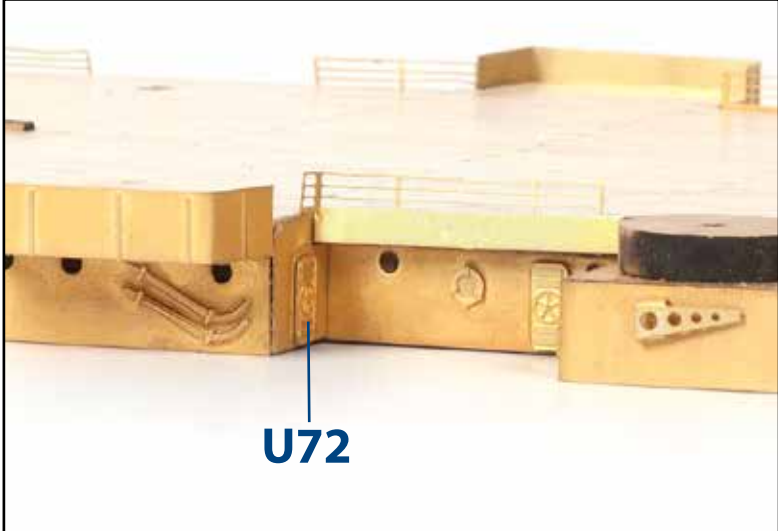
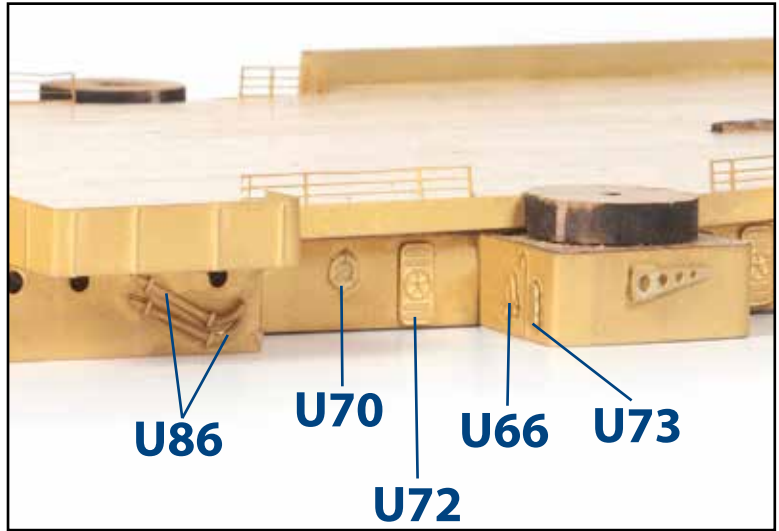
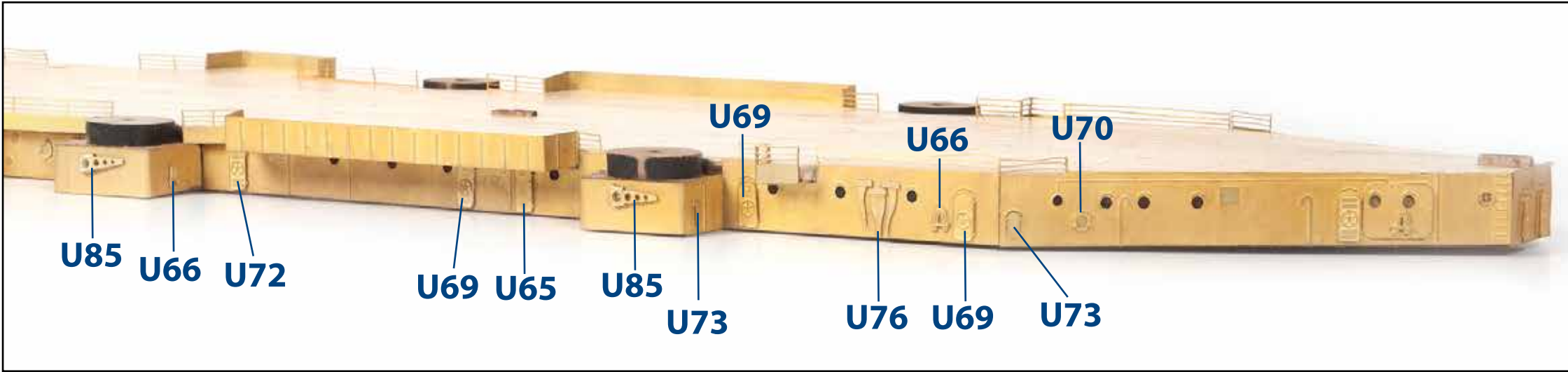
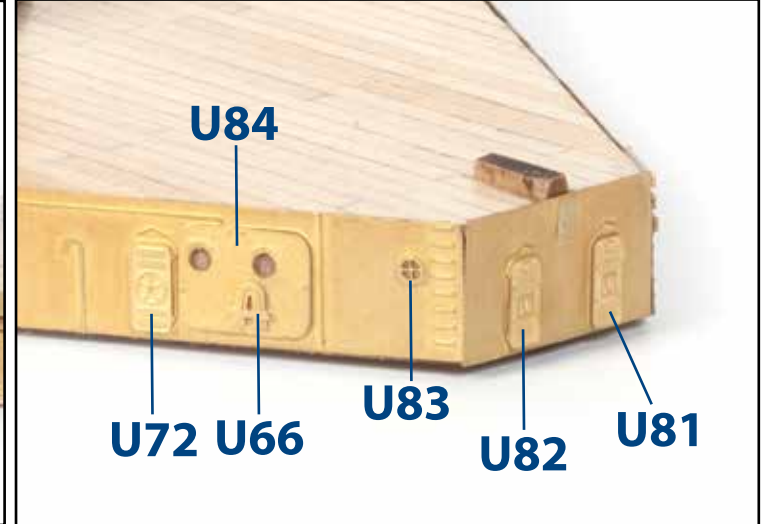
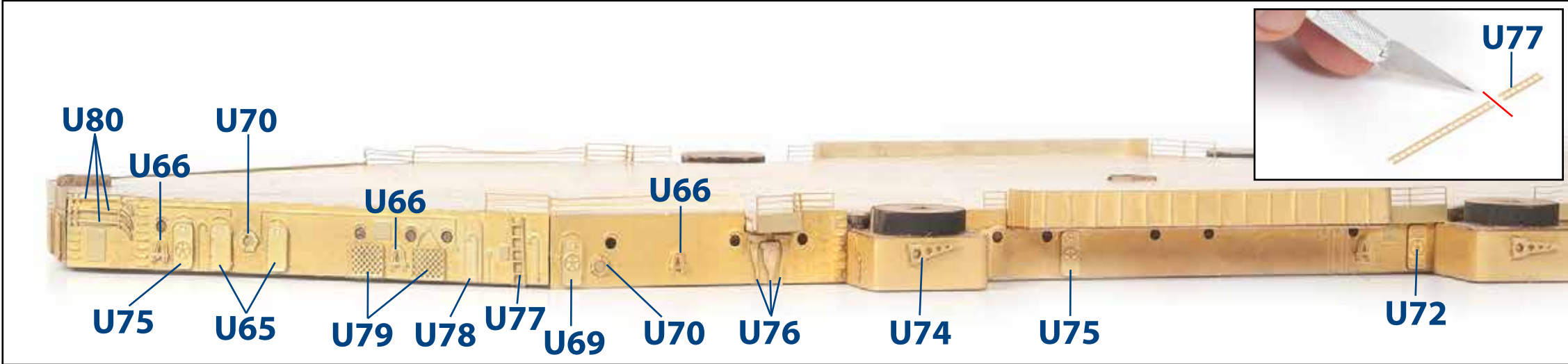
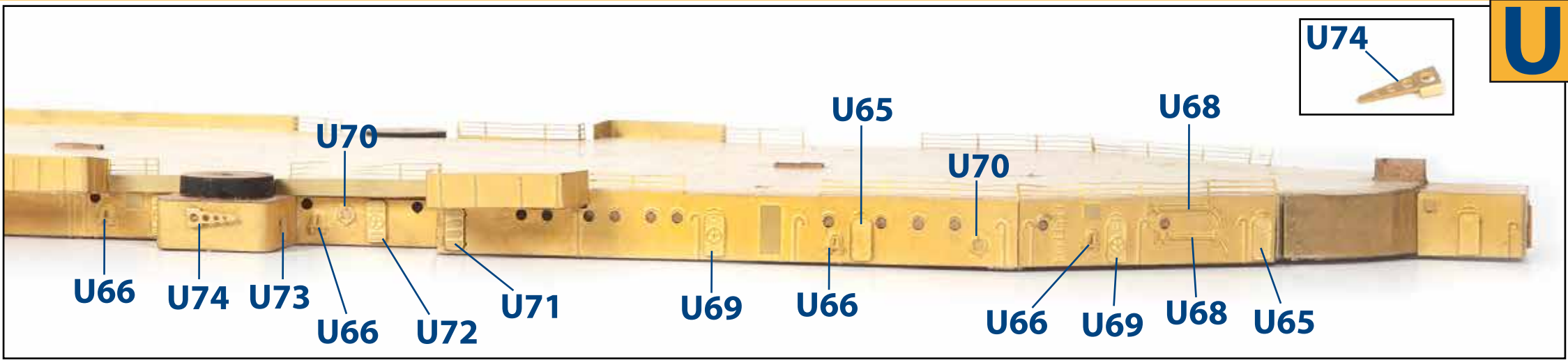
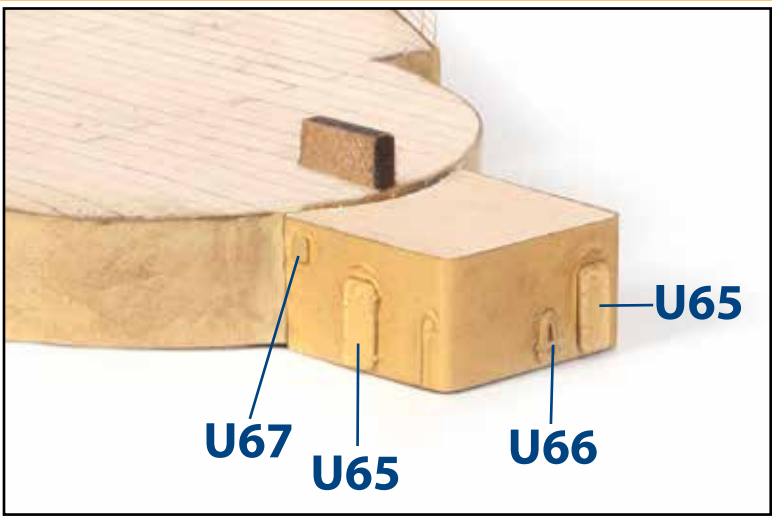

U

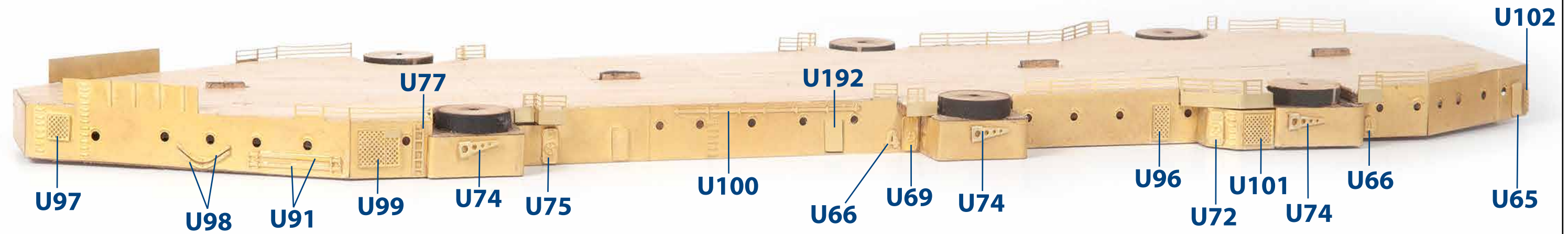
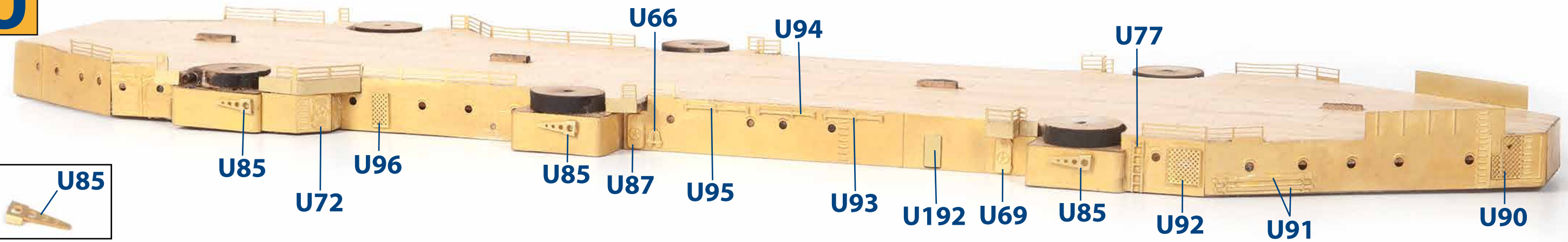

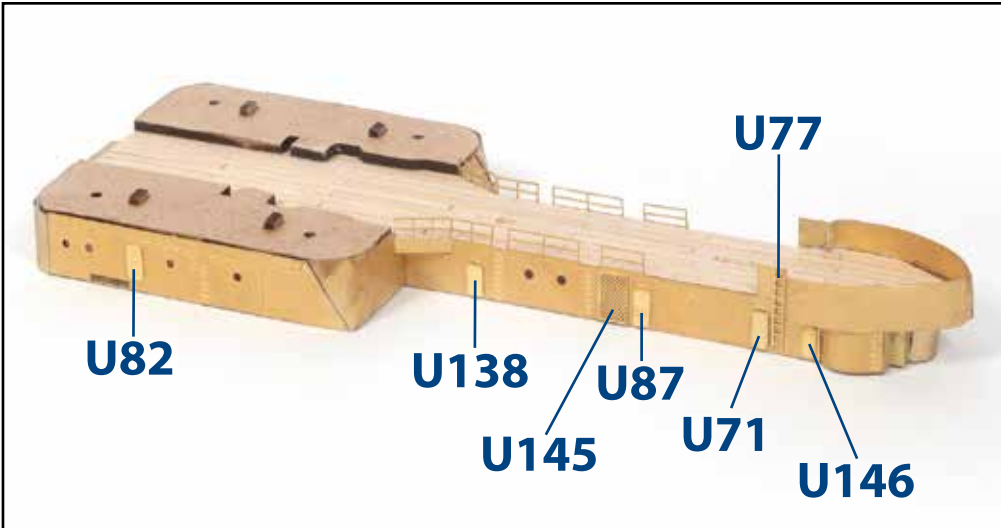
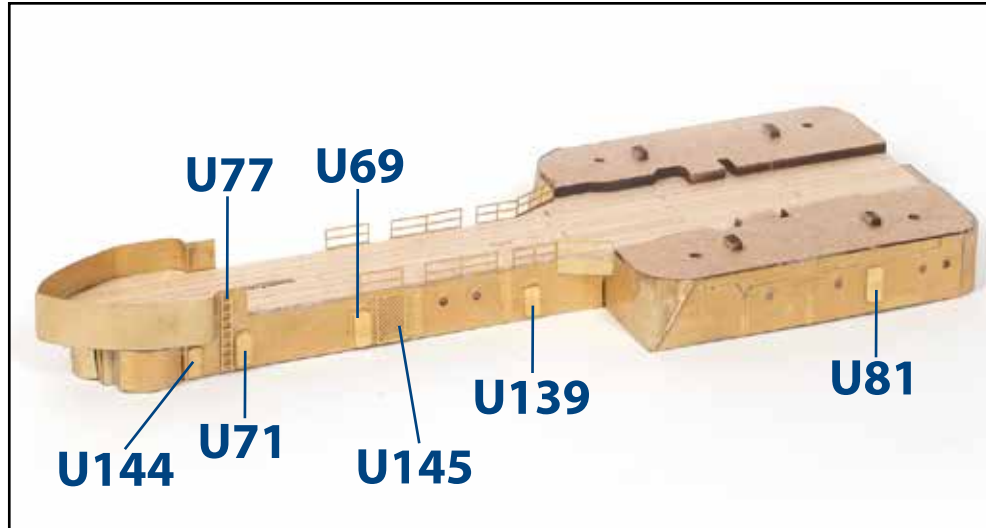
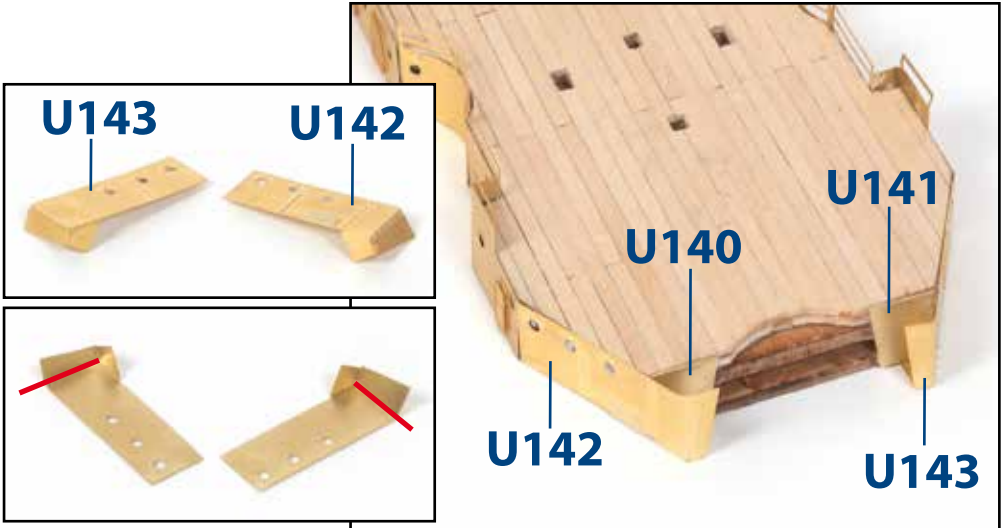
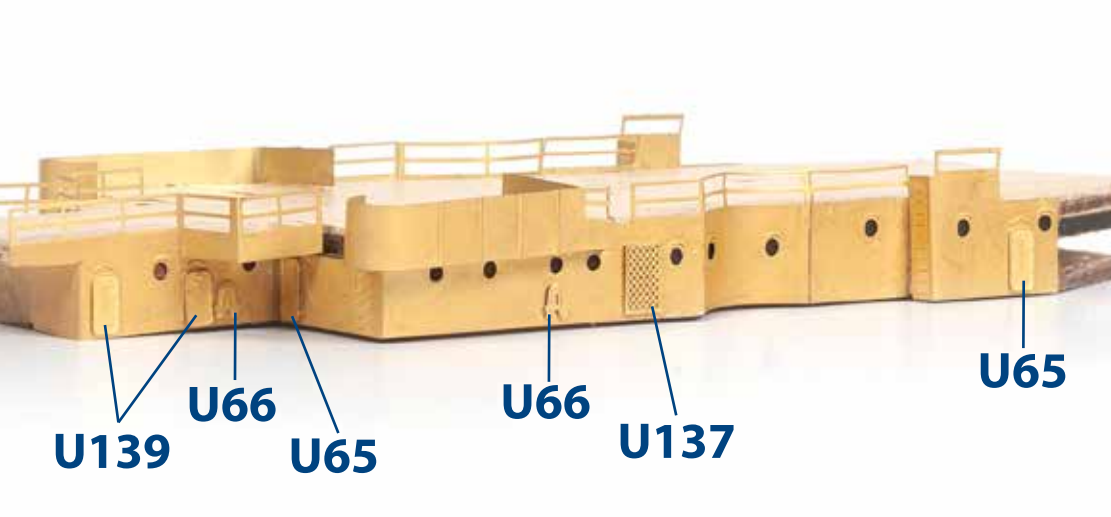
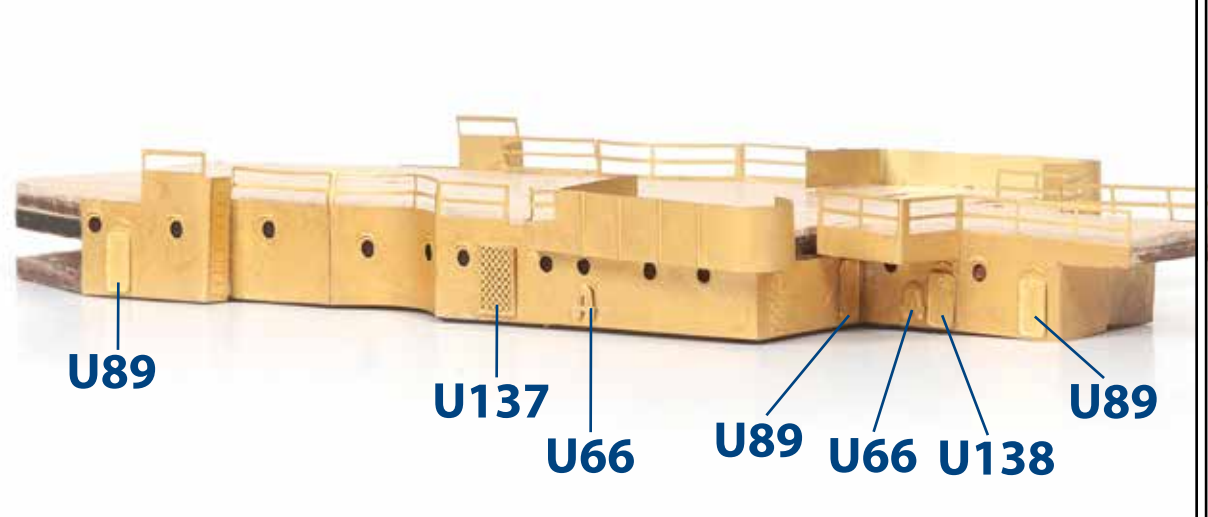
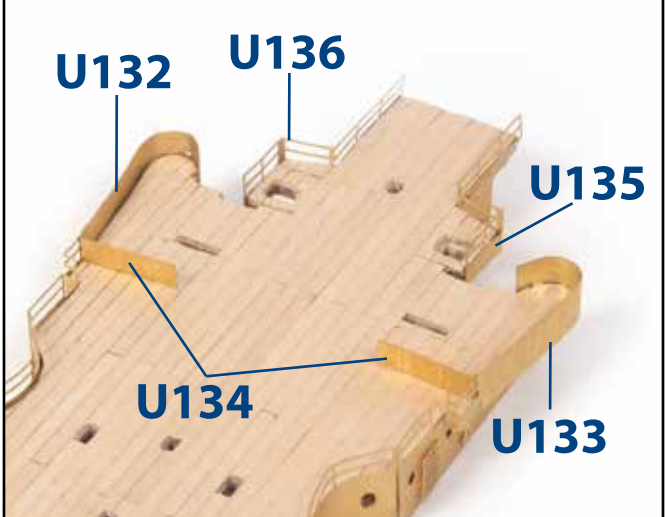
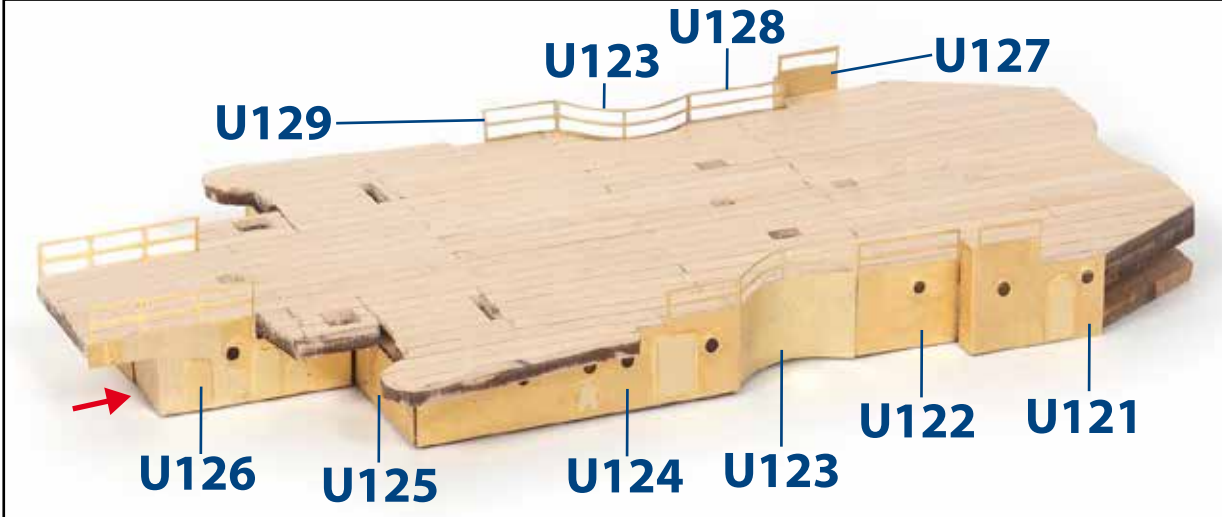
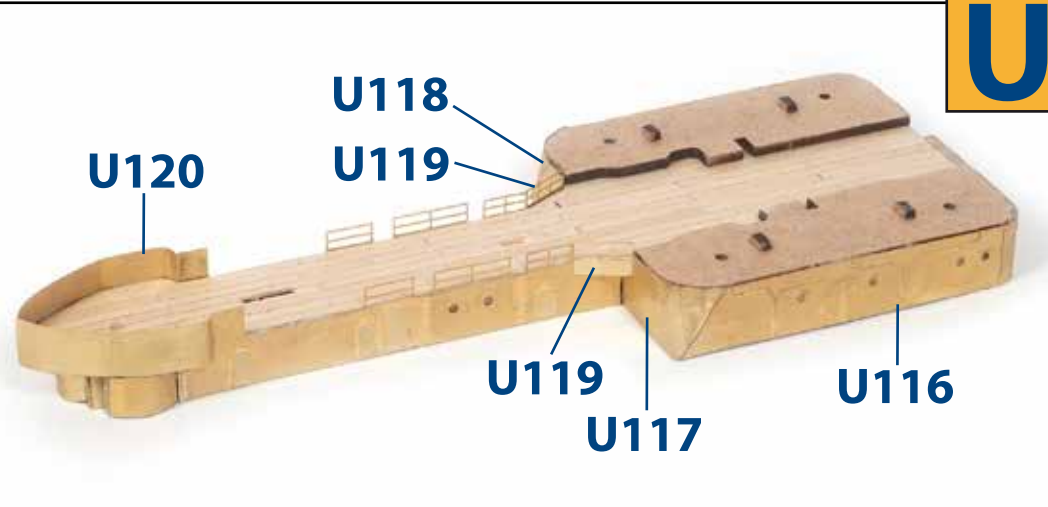
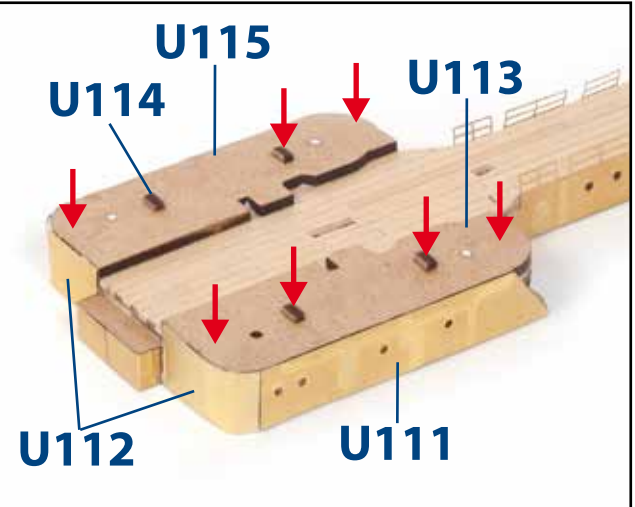
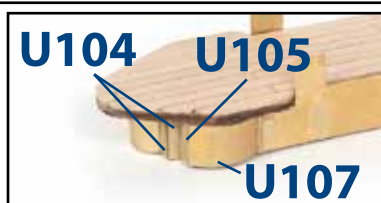
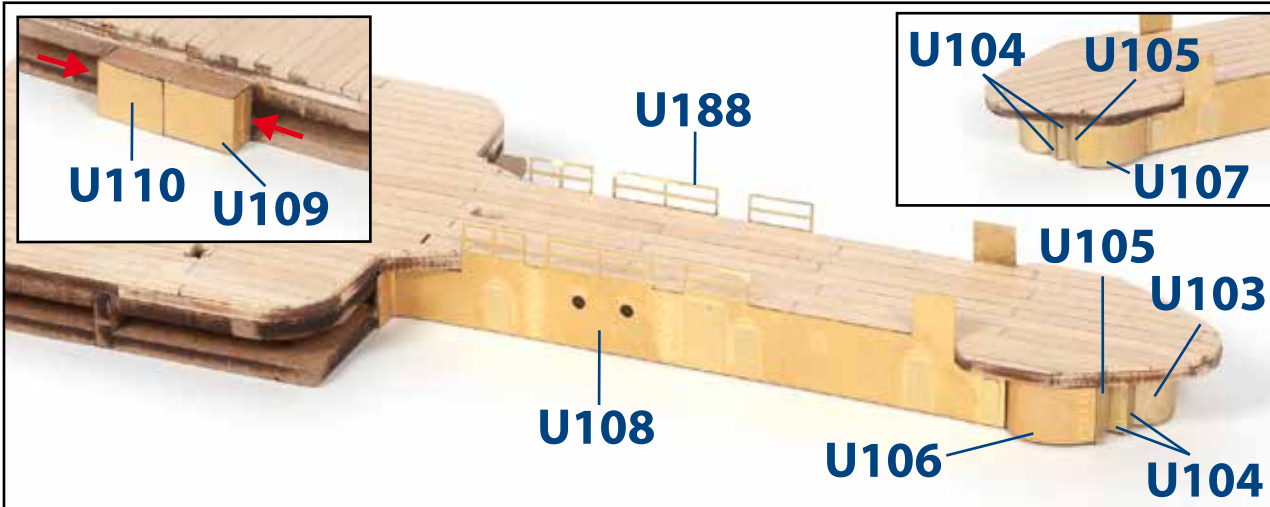

U

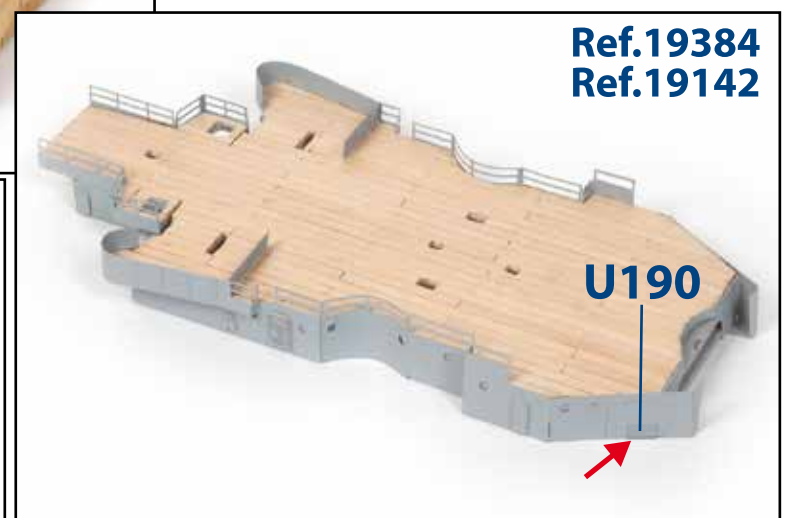
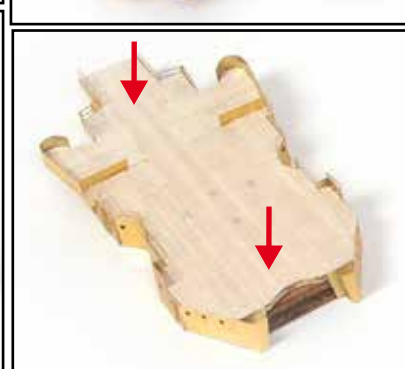
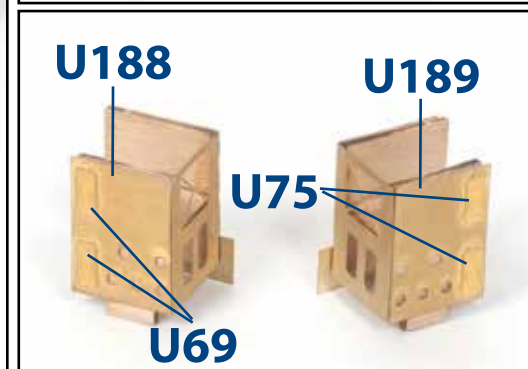
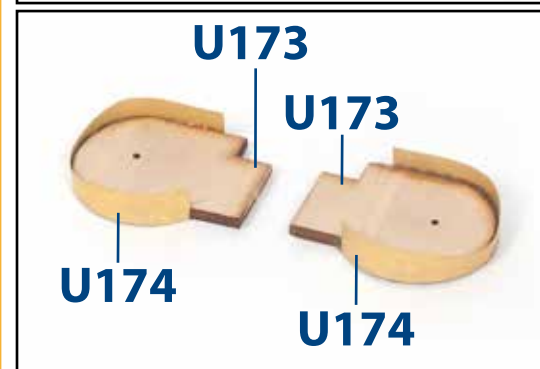
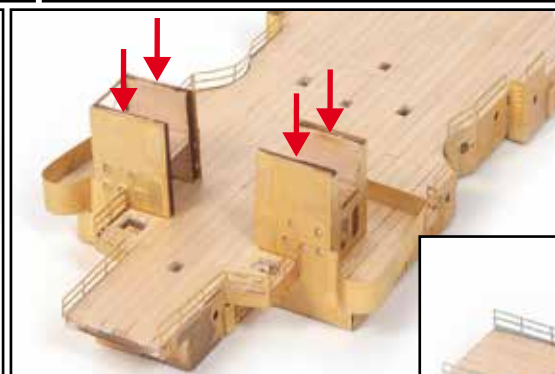
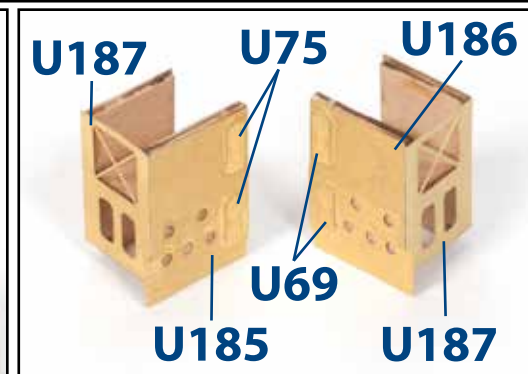
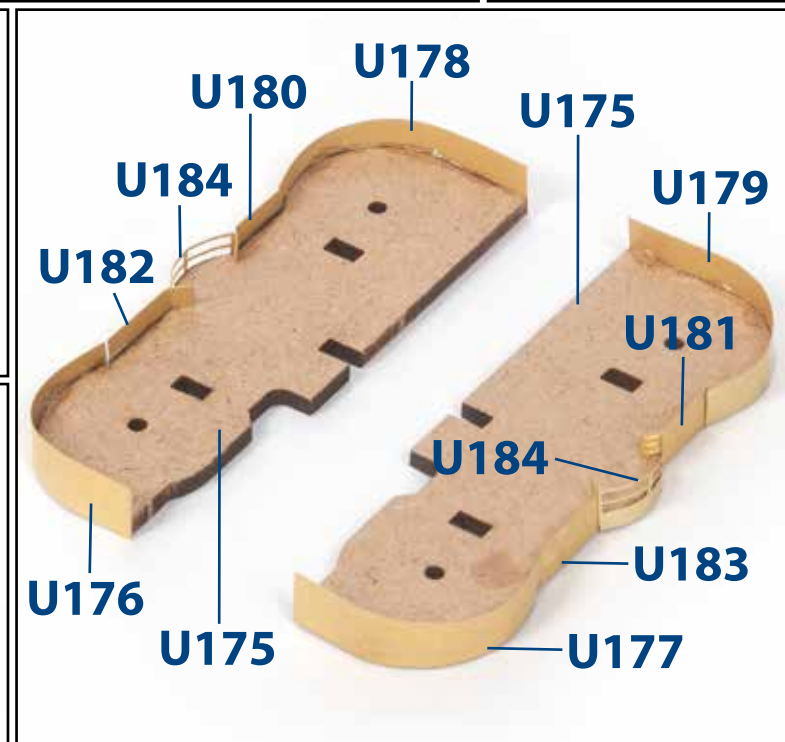
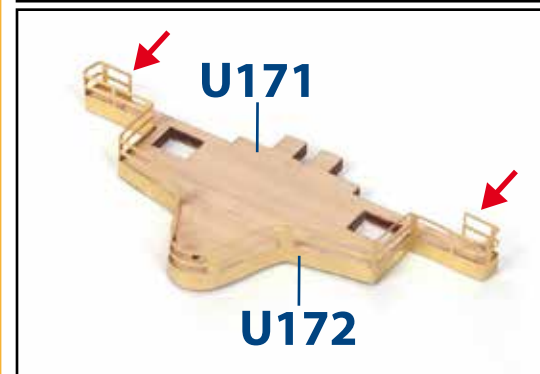
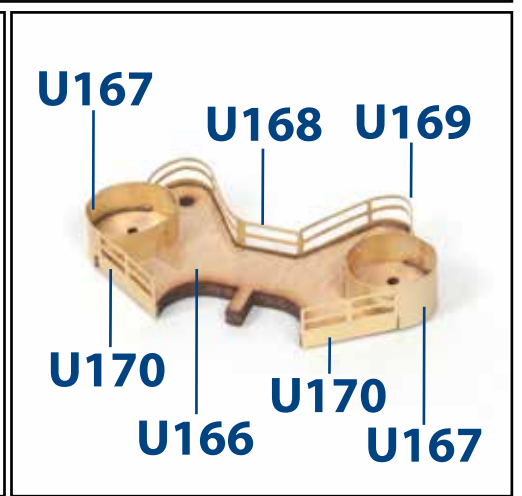
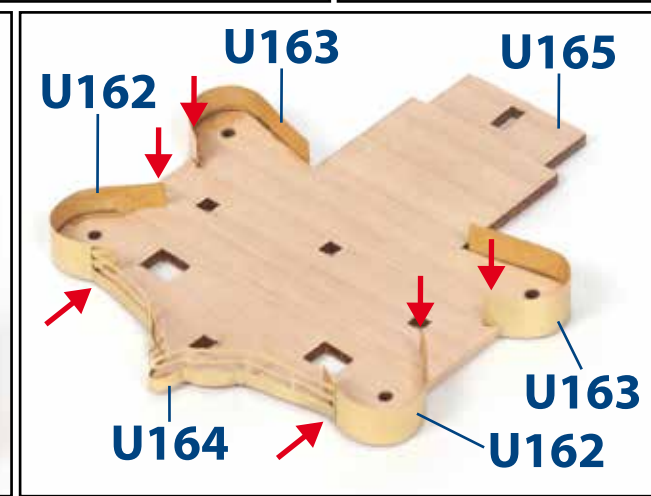
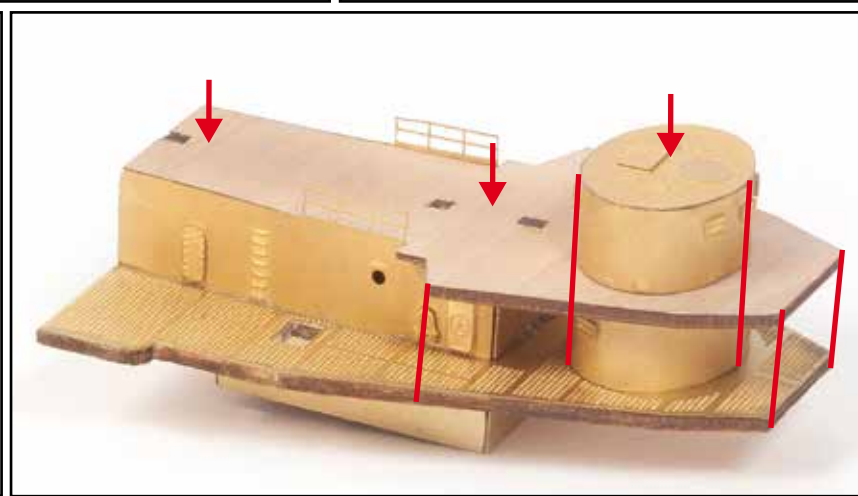
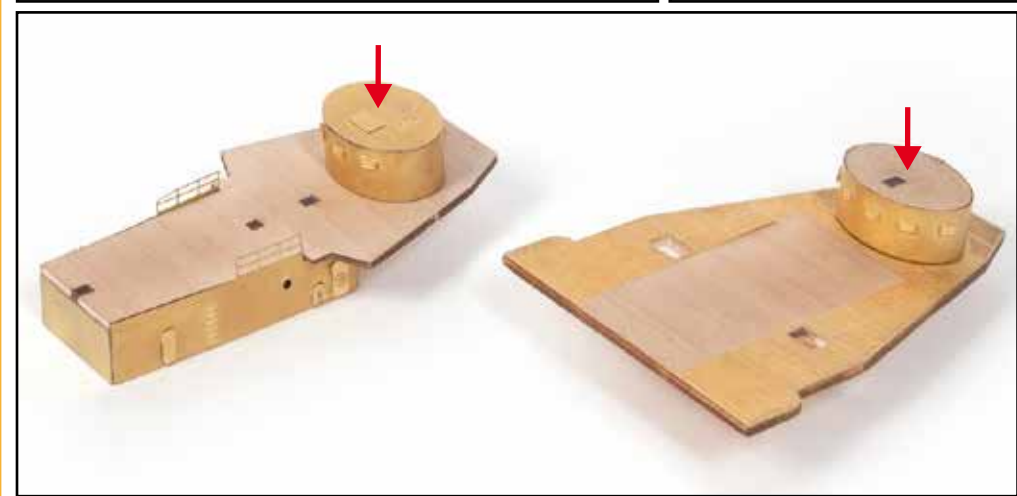
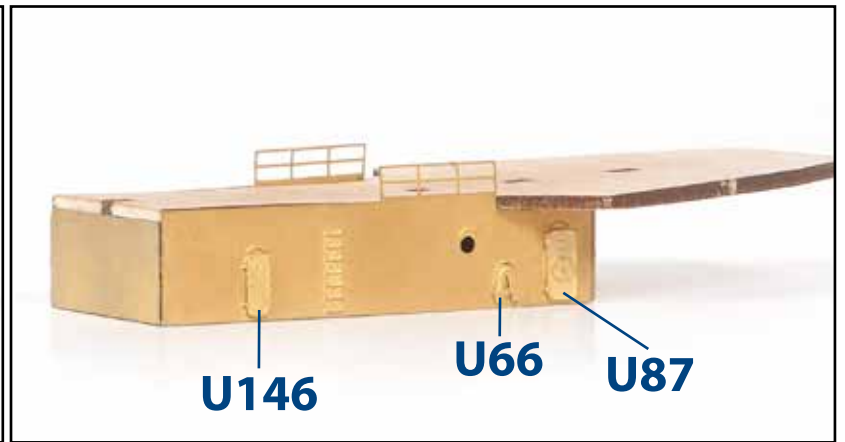
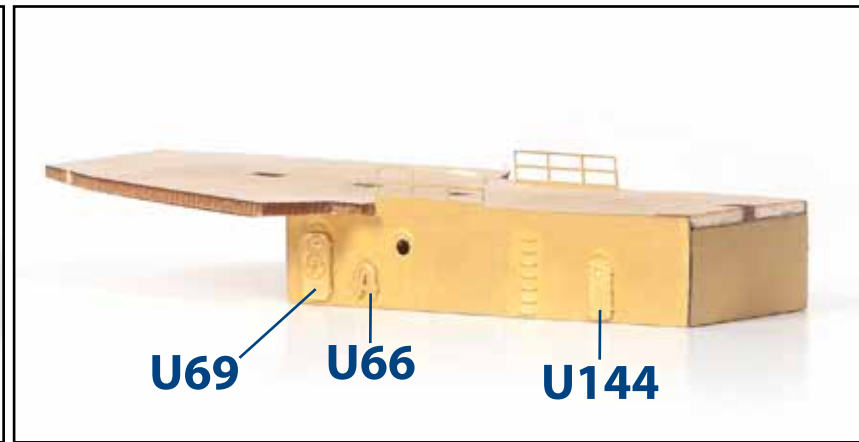
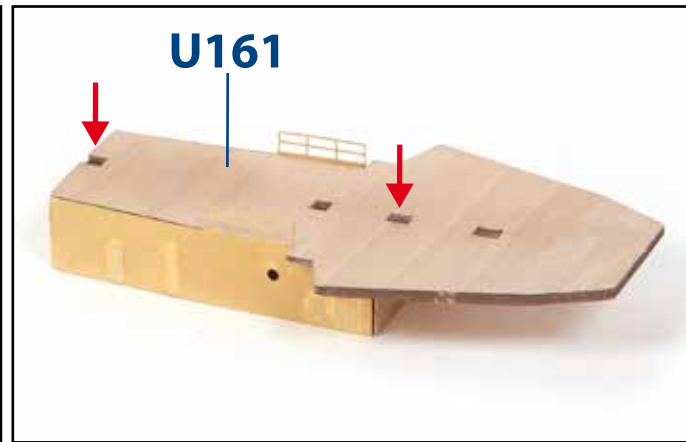
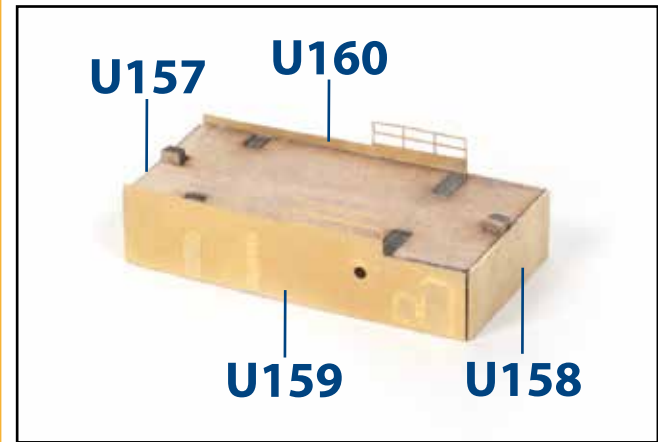
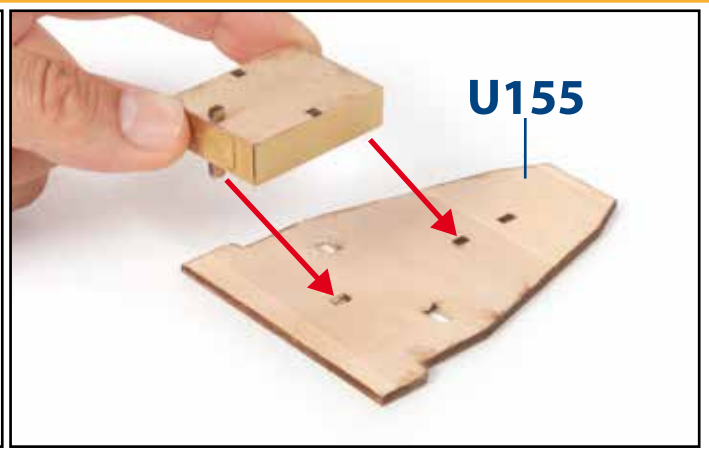
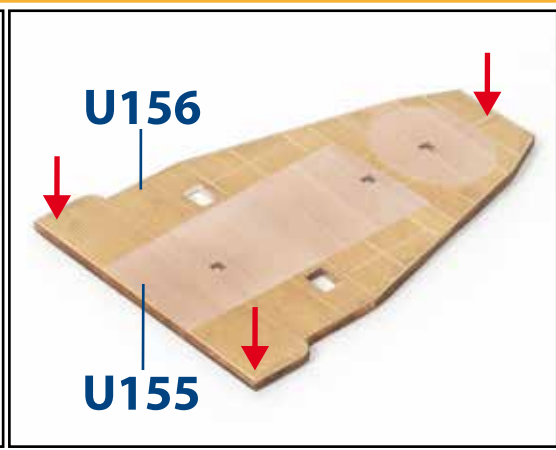
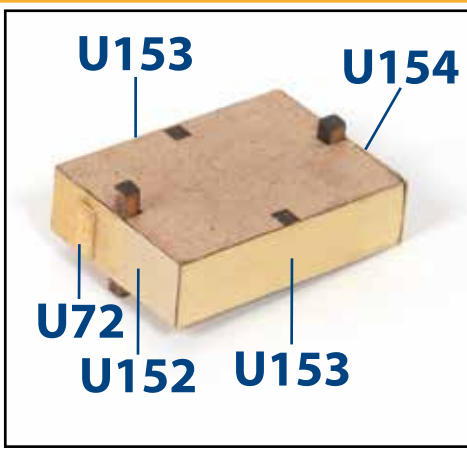
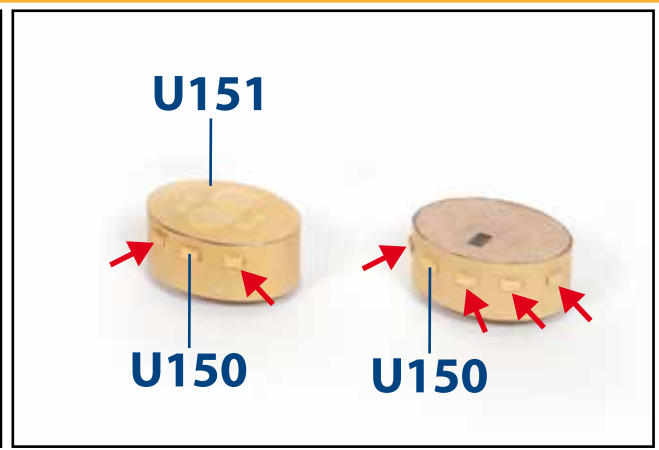
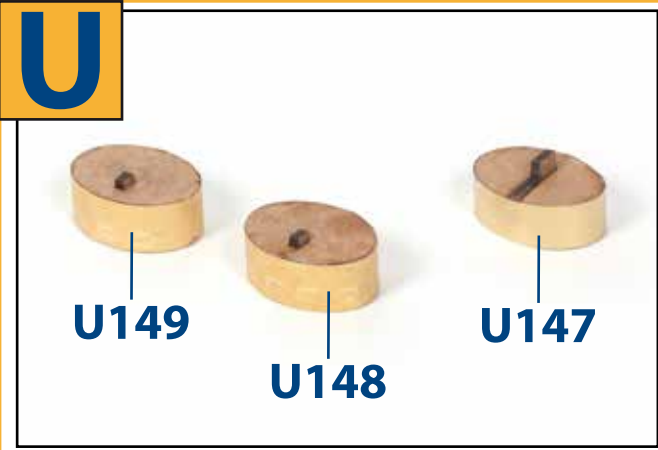

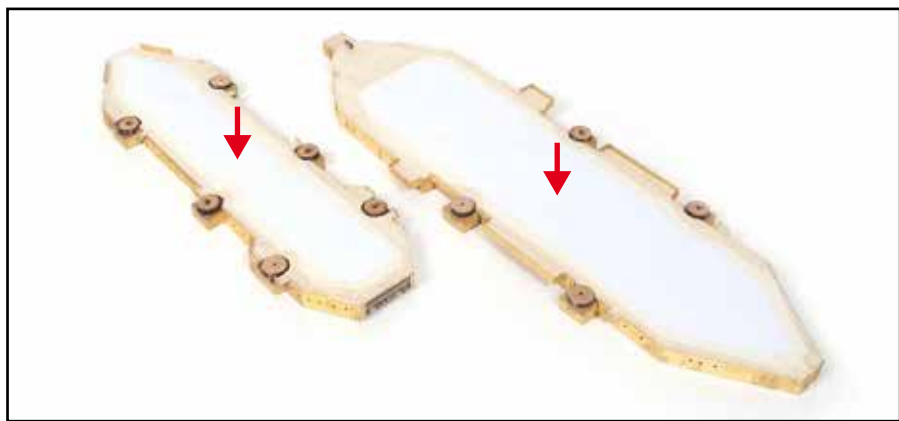
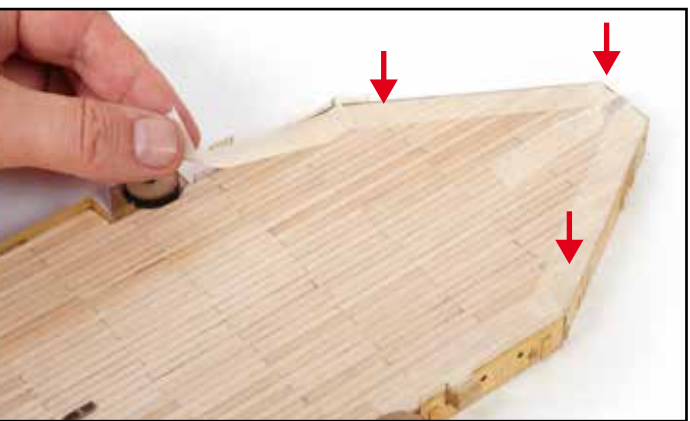
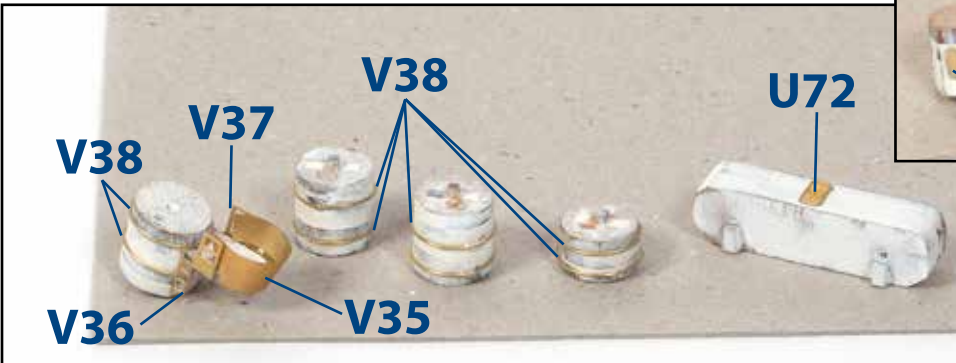
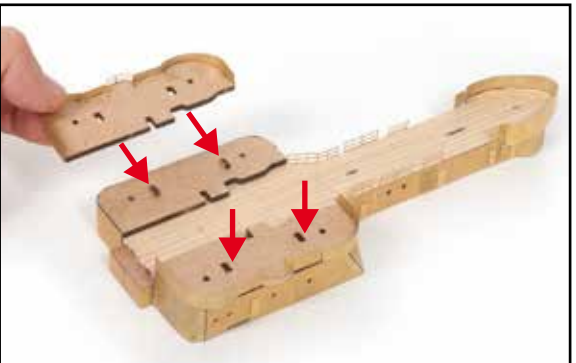
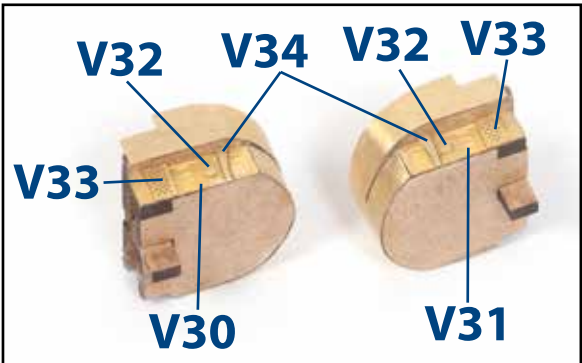
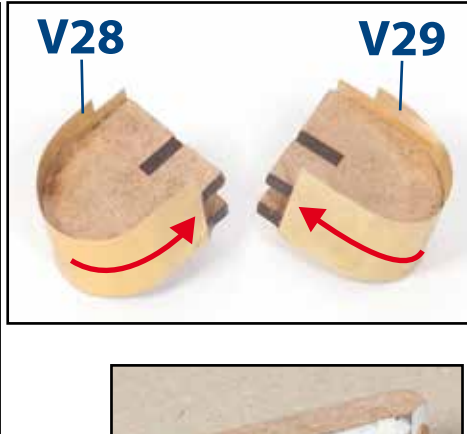
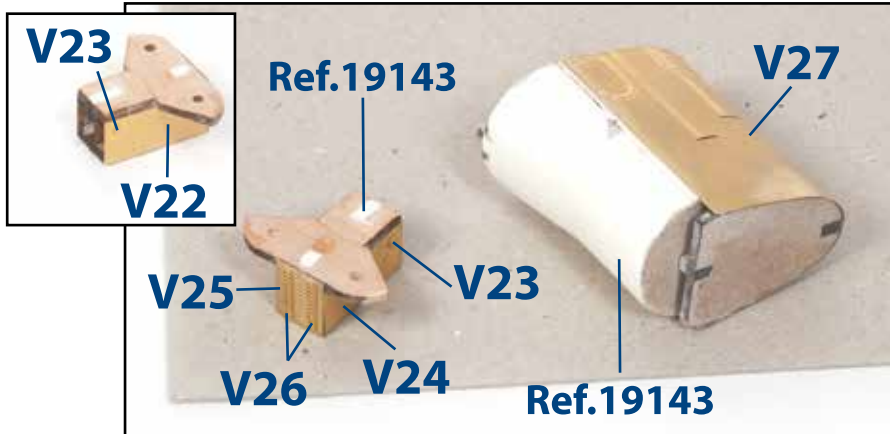
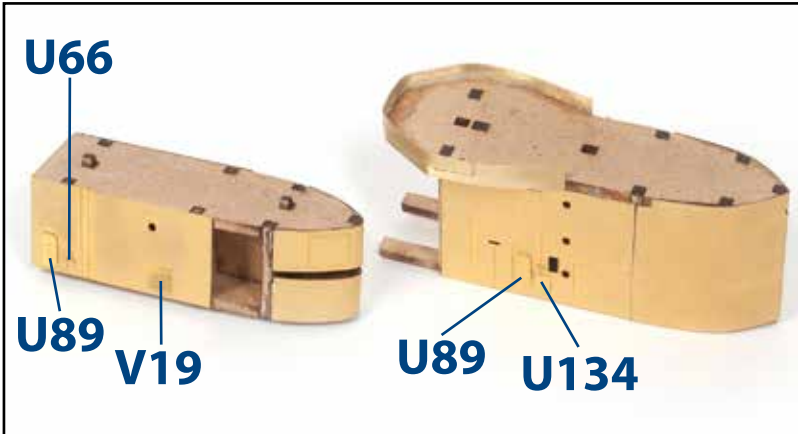
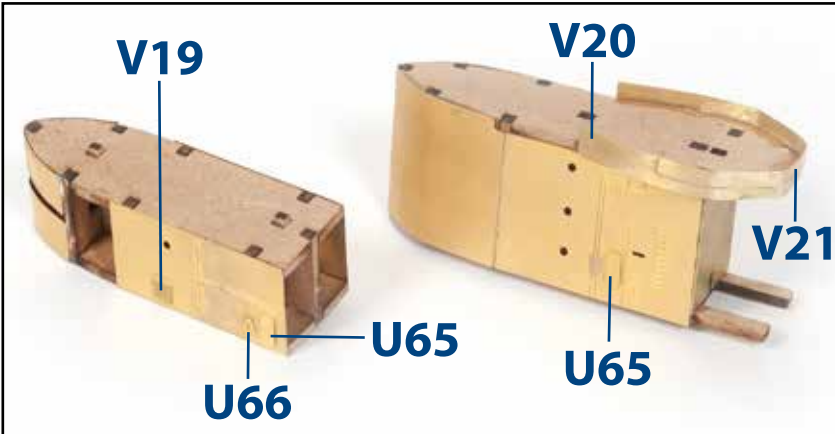
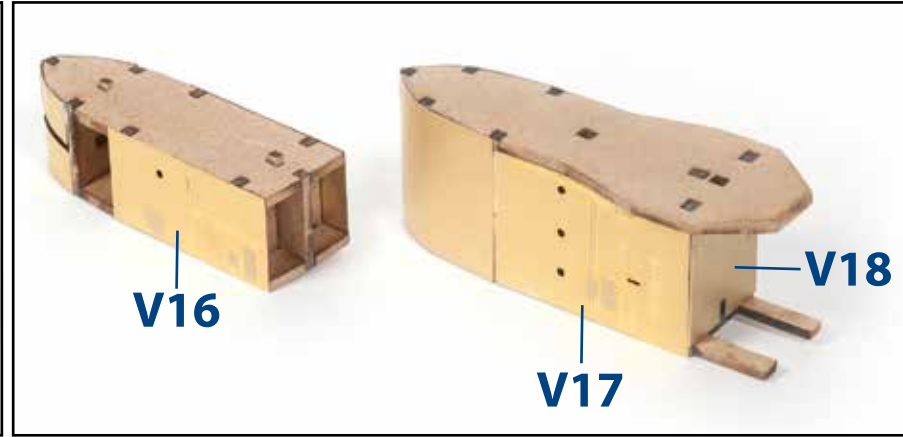
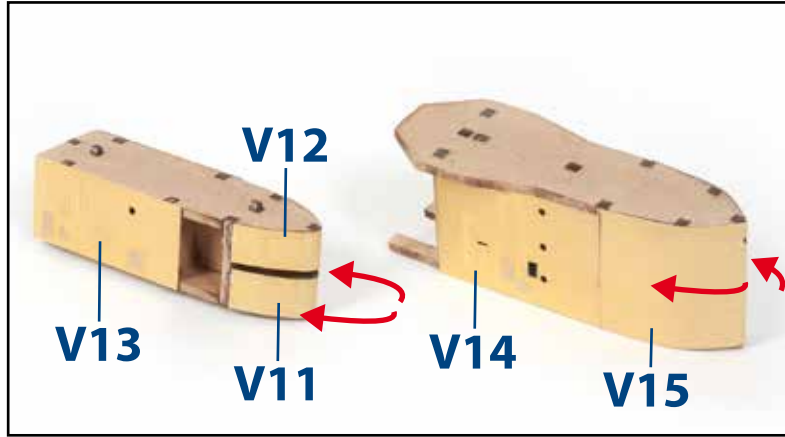
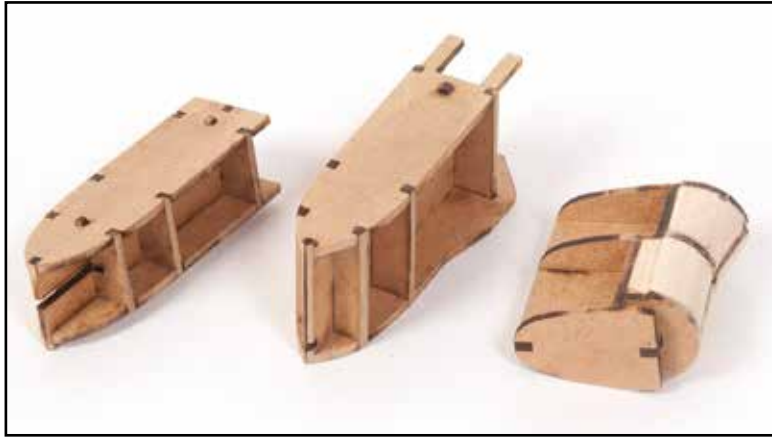
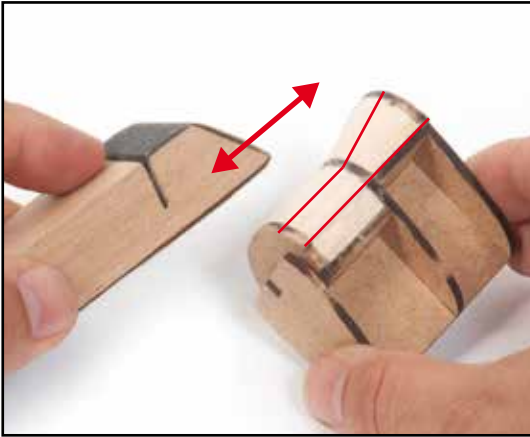
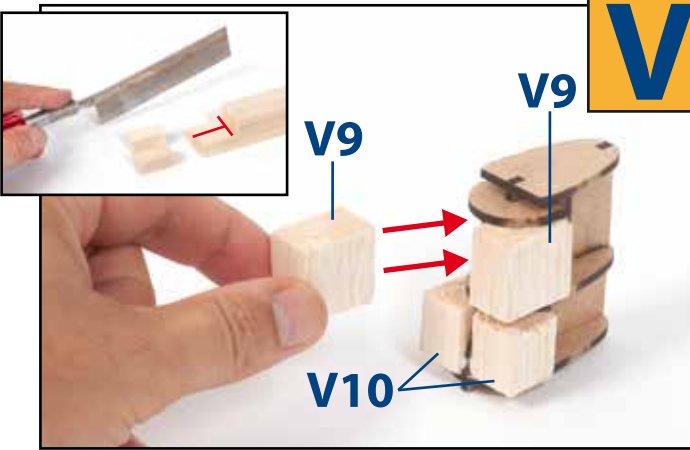
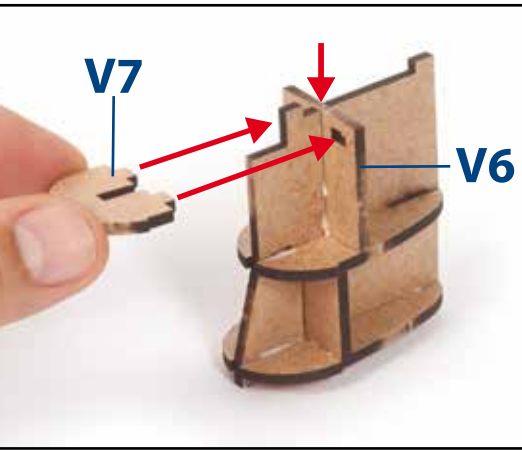
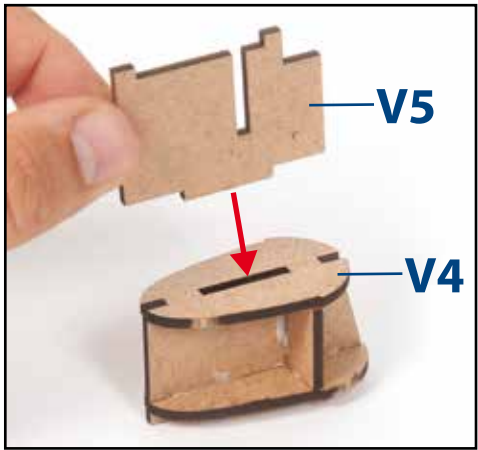
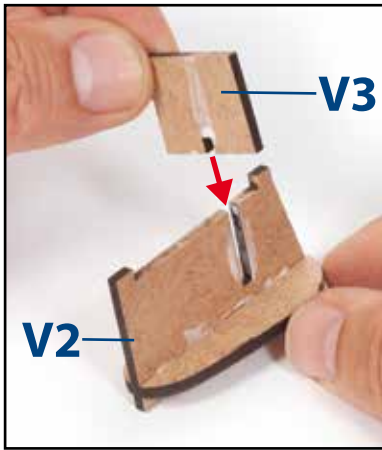
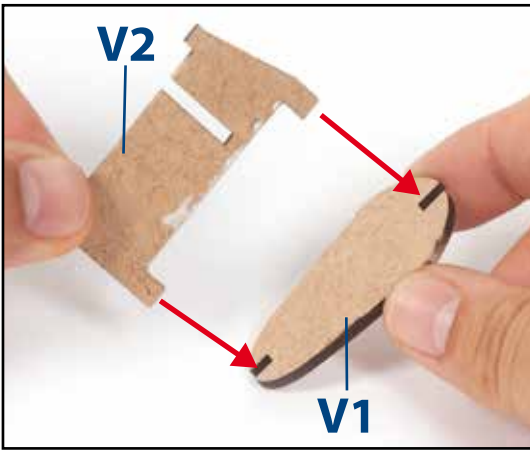

Assembly manual for a wooden structure, showing steps V1 through V26. Each step includes a photograph of the assembly process with red arrows indicating the placement of parts. Parts are labeled with alphanumeric codes (V1-V38, U65-U73). Reference numbers (Ref.19143, Ref.19384, Ref.19142) are provided for specific components. A yellow box with a blue 'V' is in the top right corner.

V

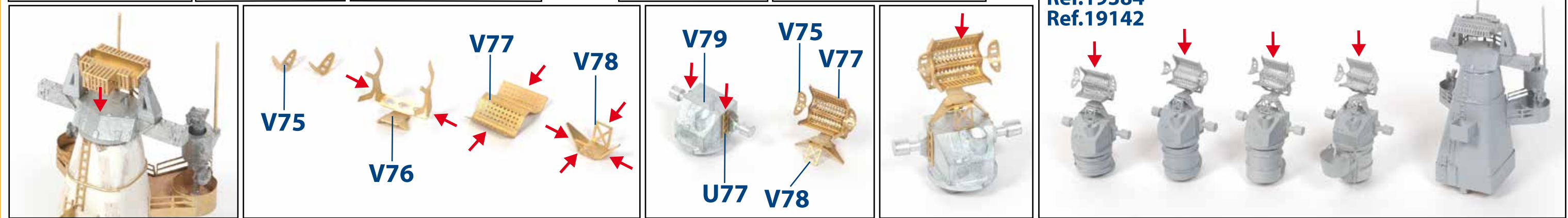
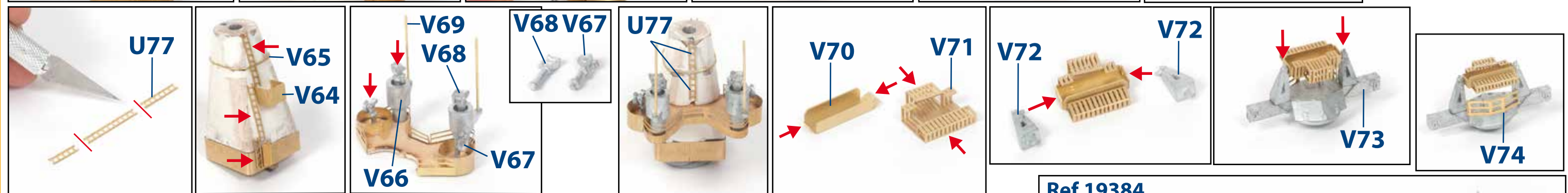
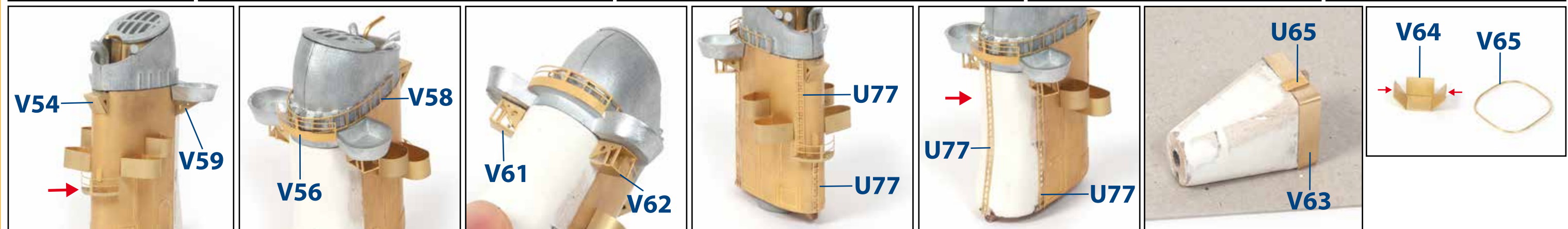
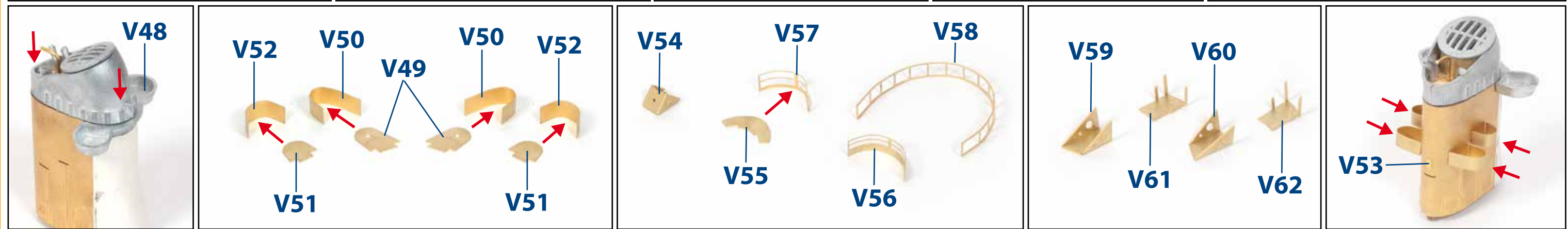
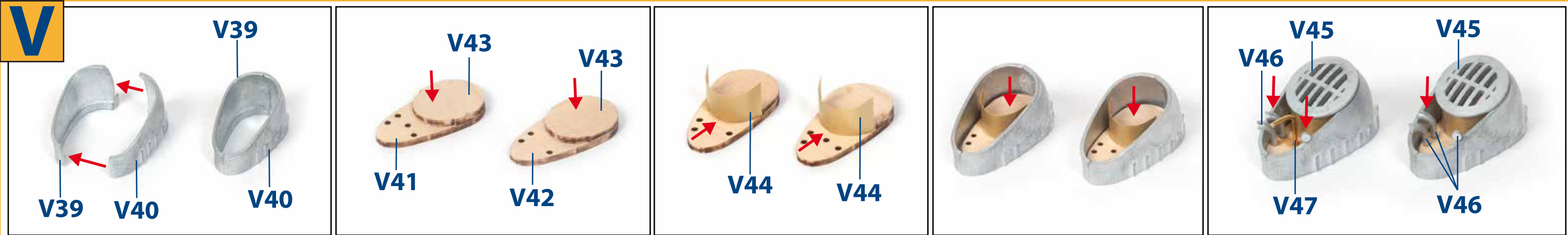

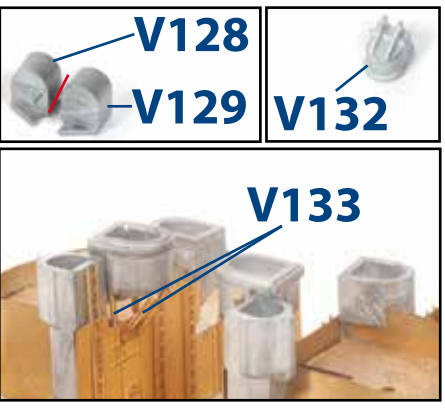
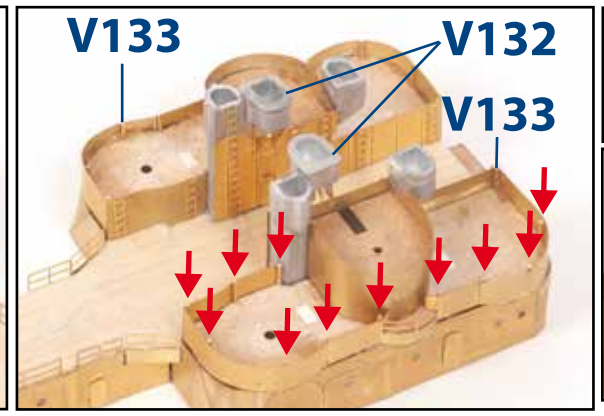
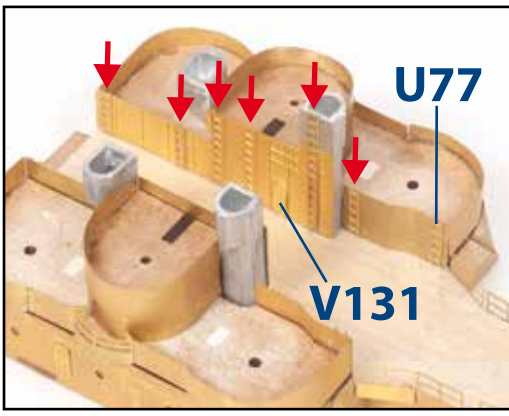
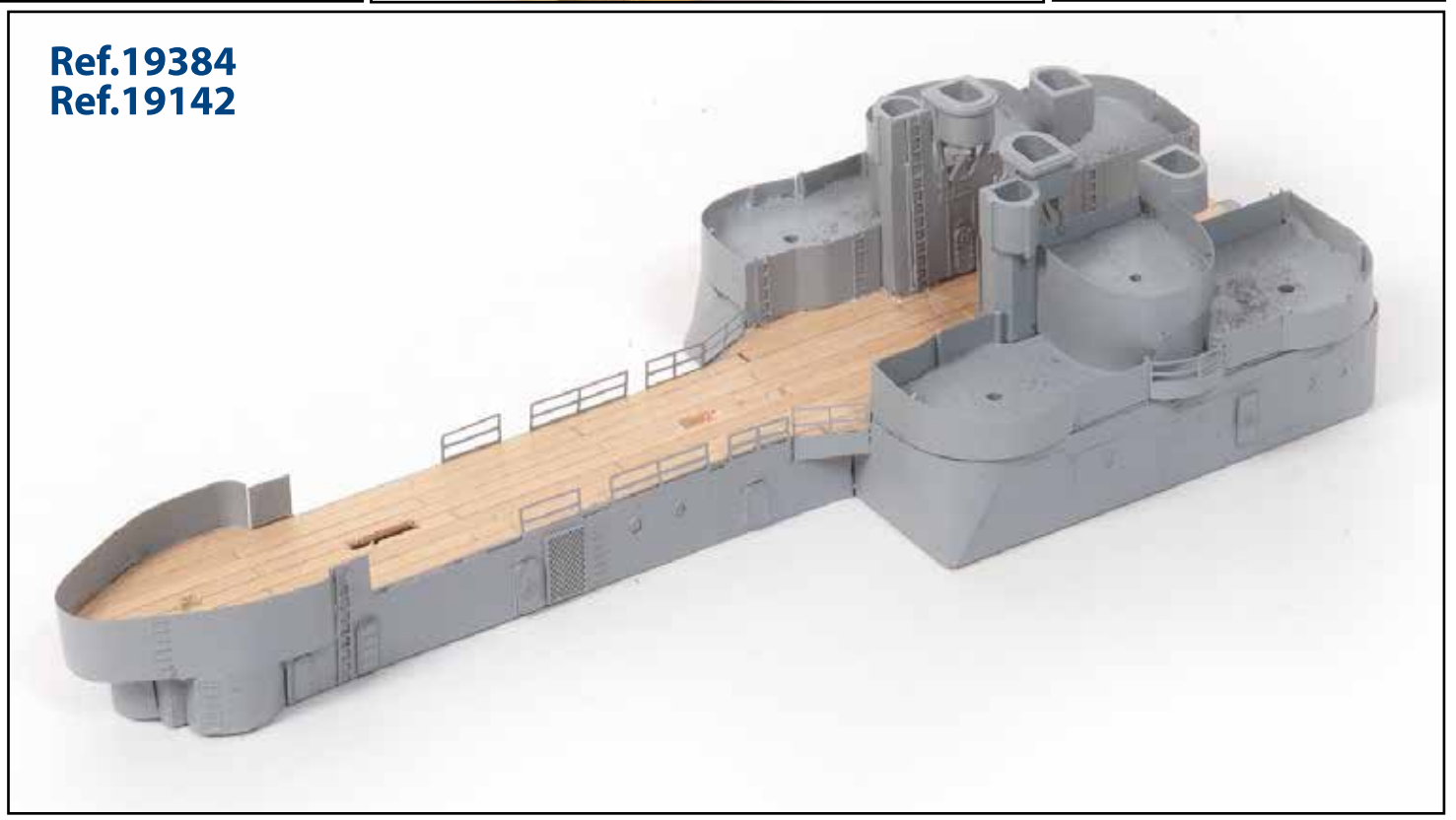
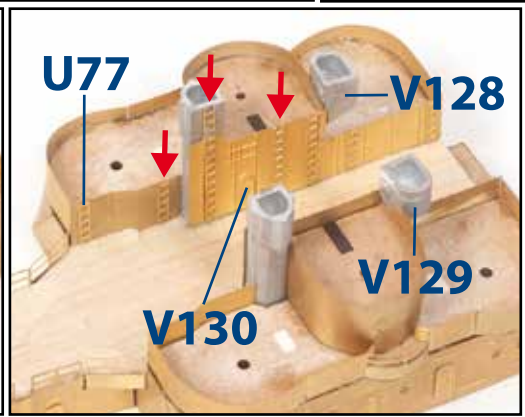
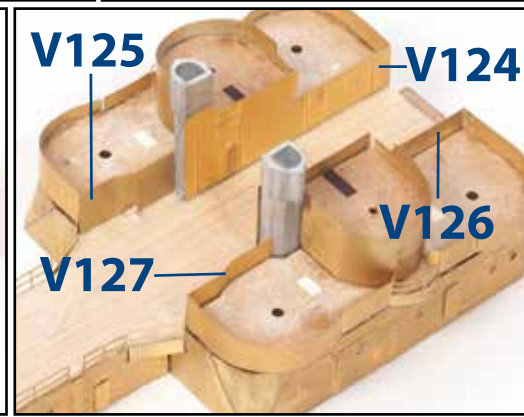
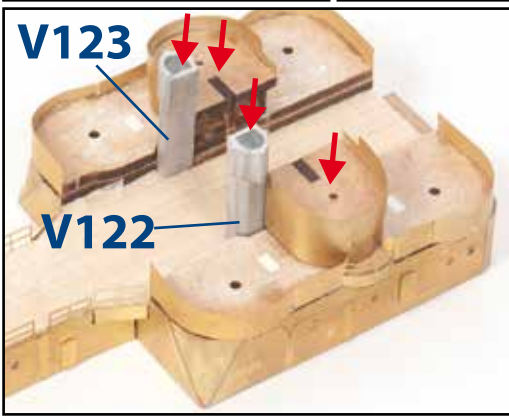
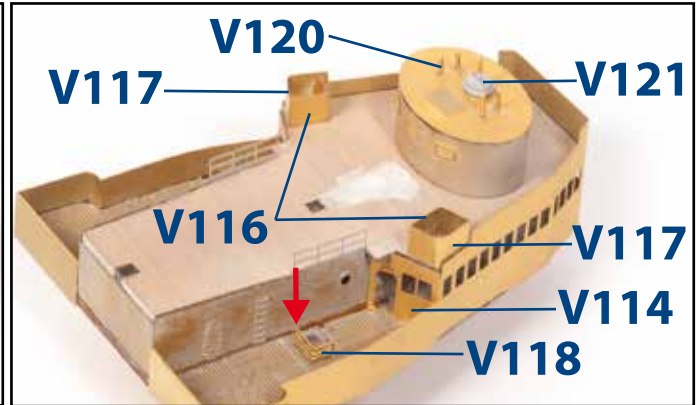
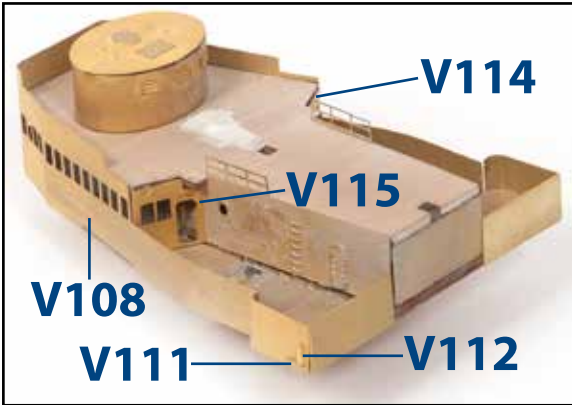
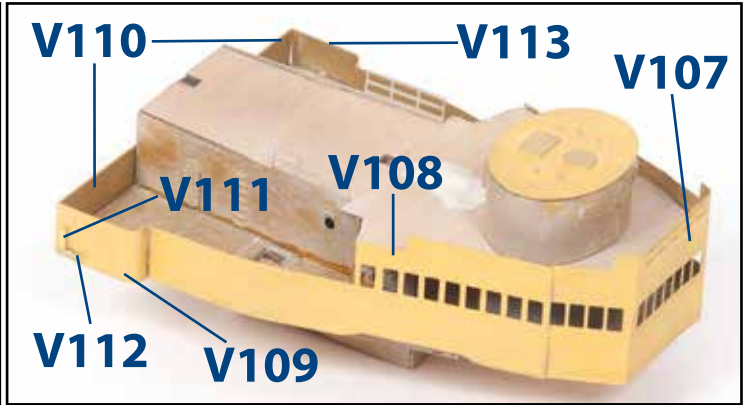
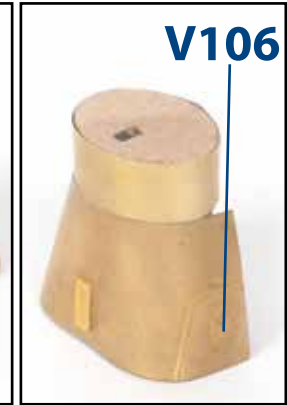
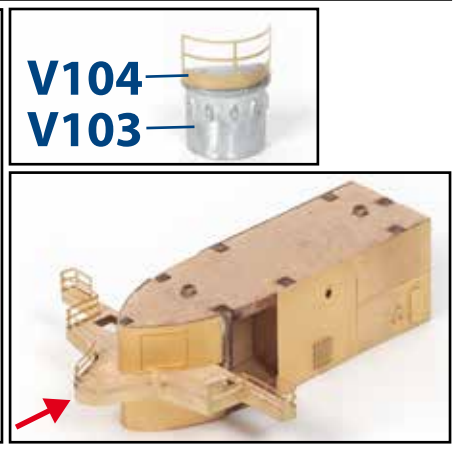
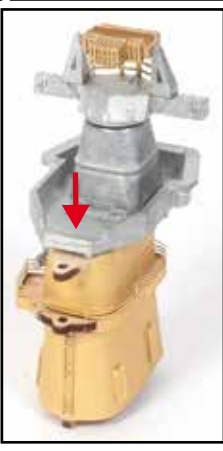
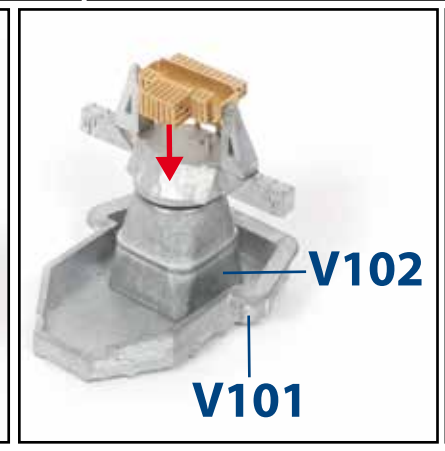
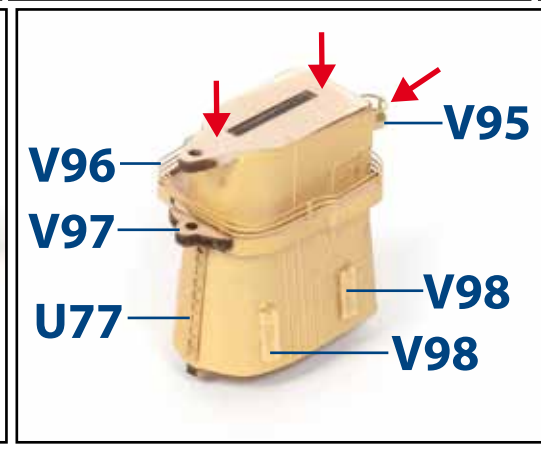
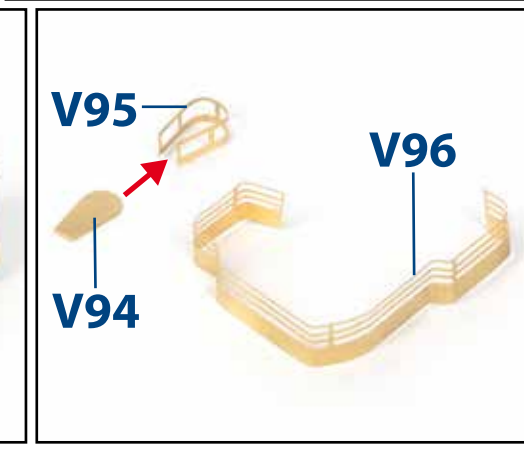
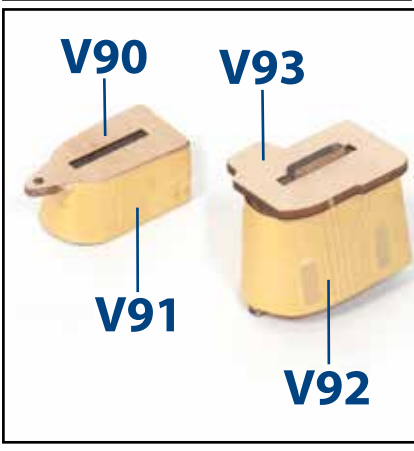
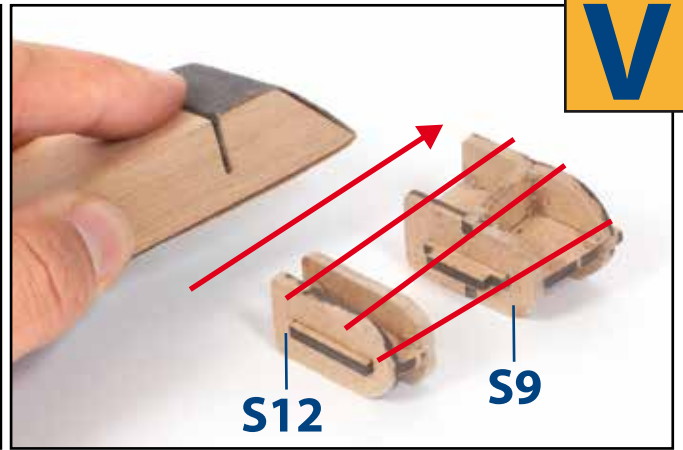
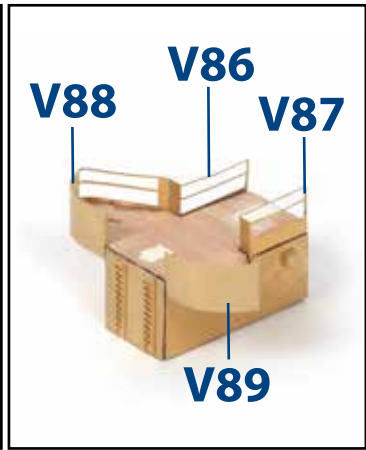
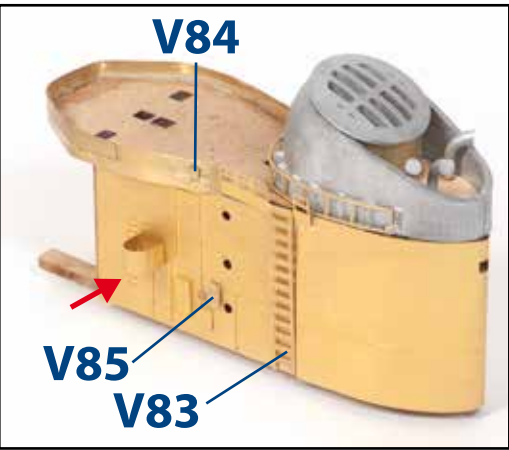
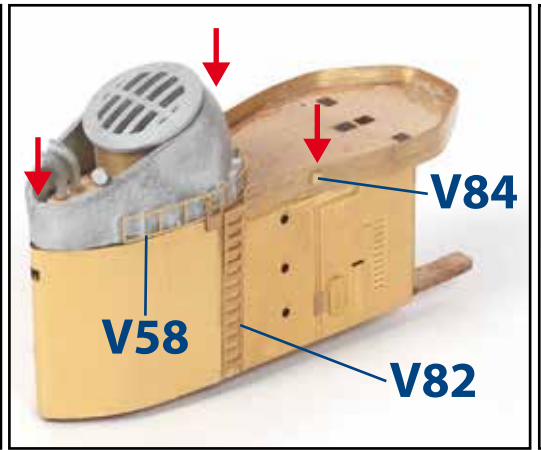
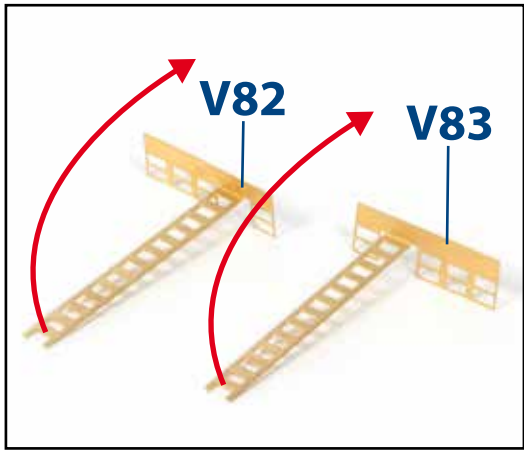
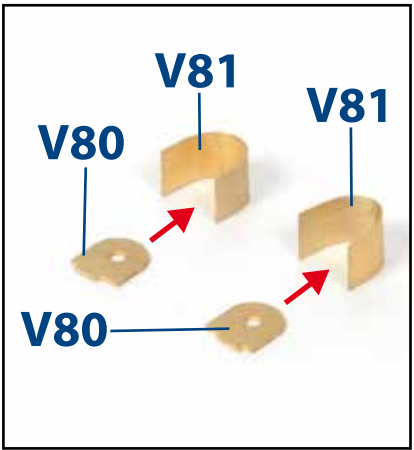

W

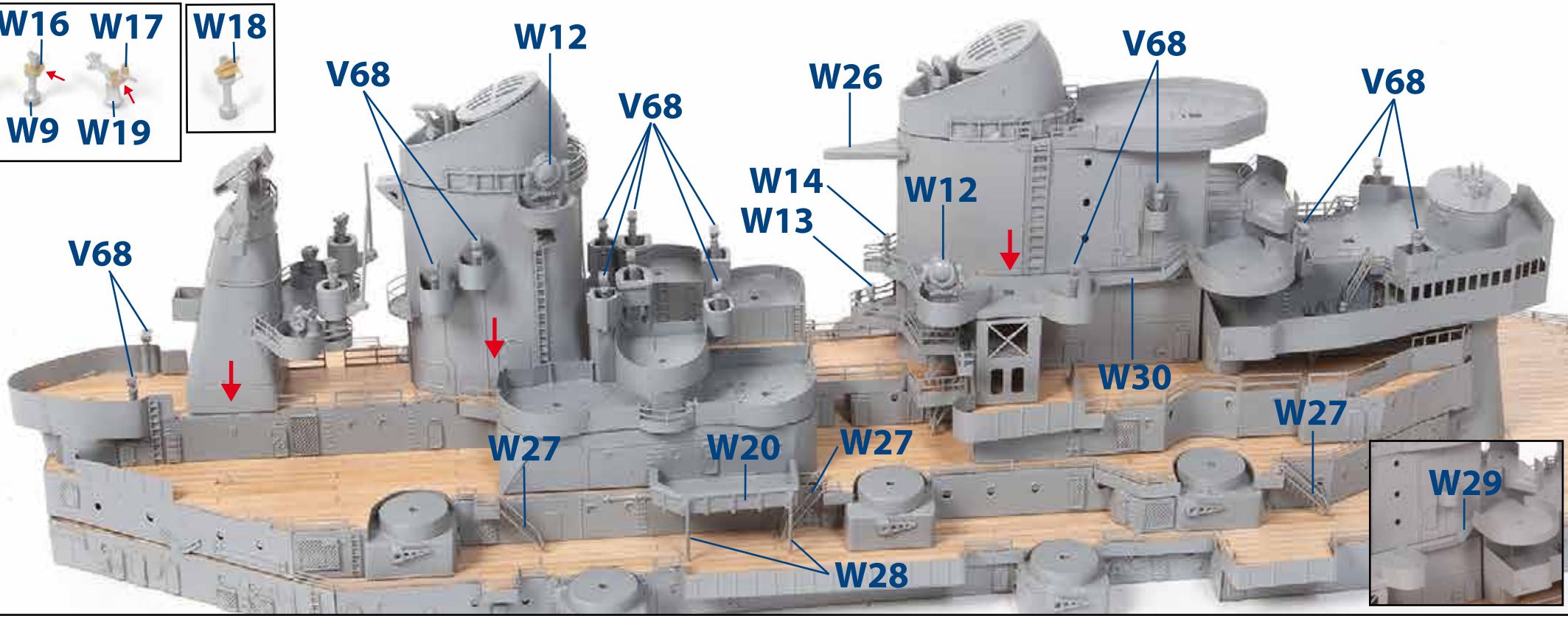
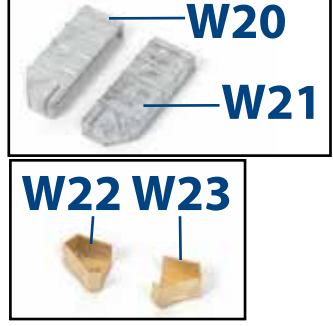
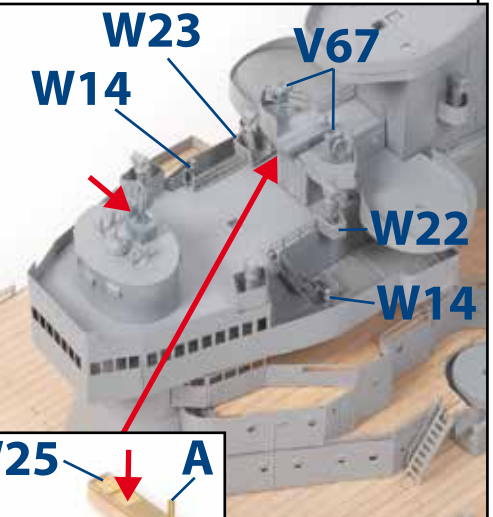
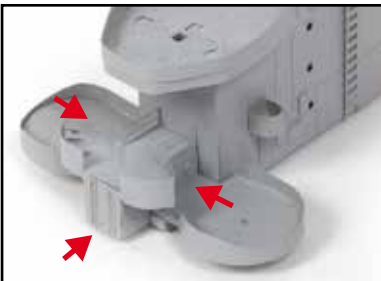
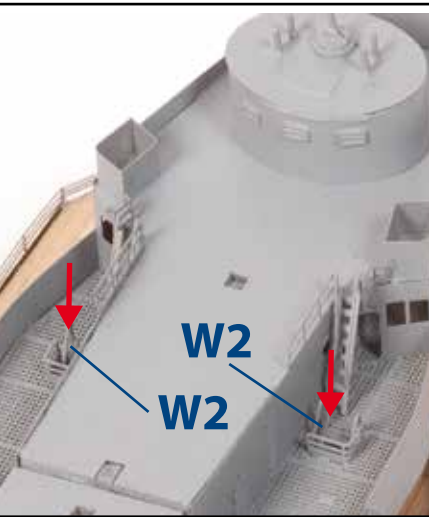
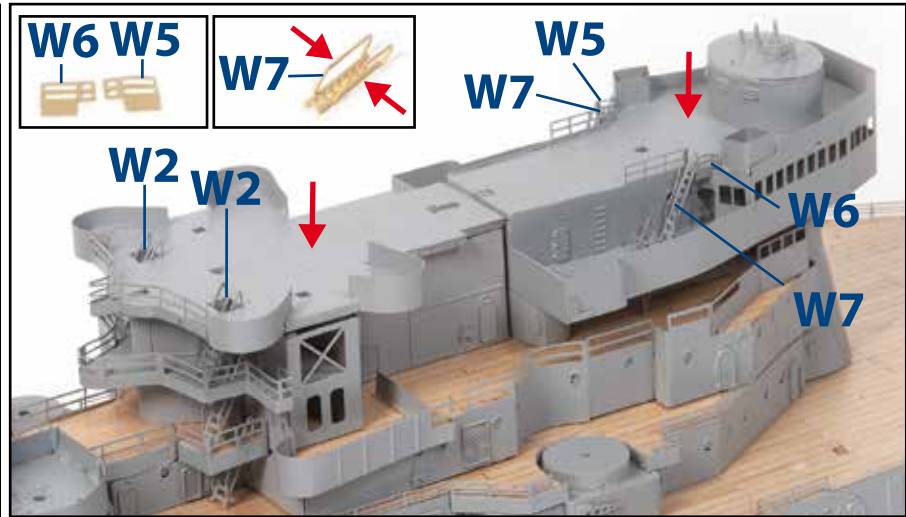
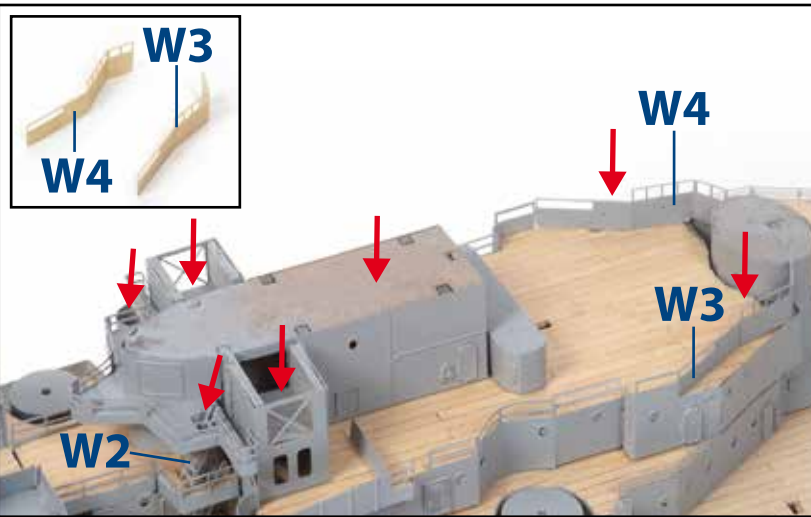
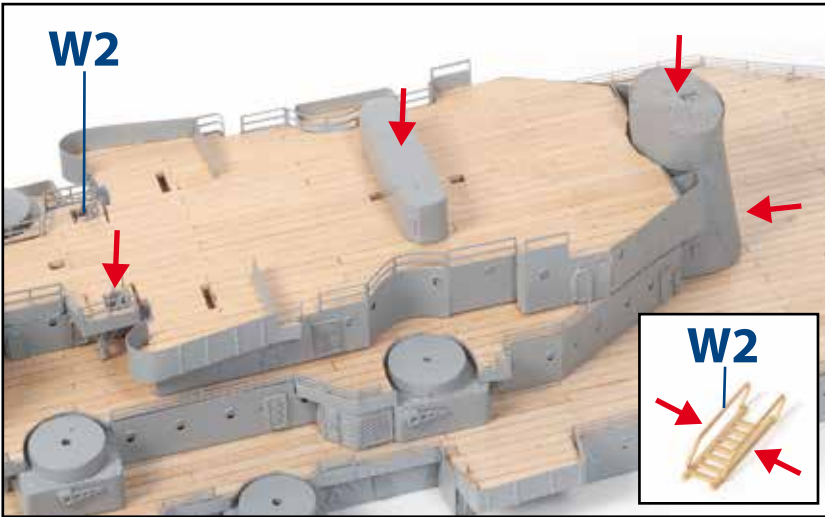
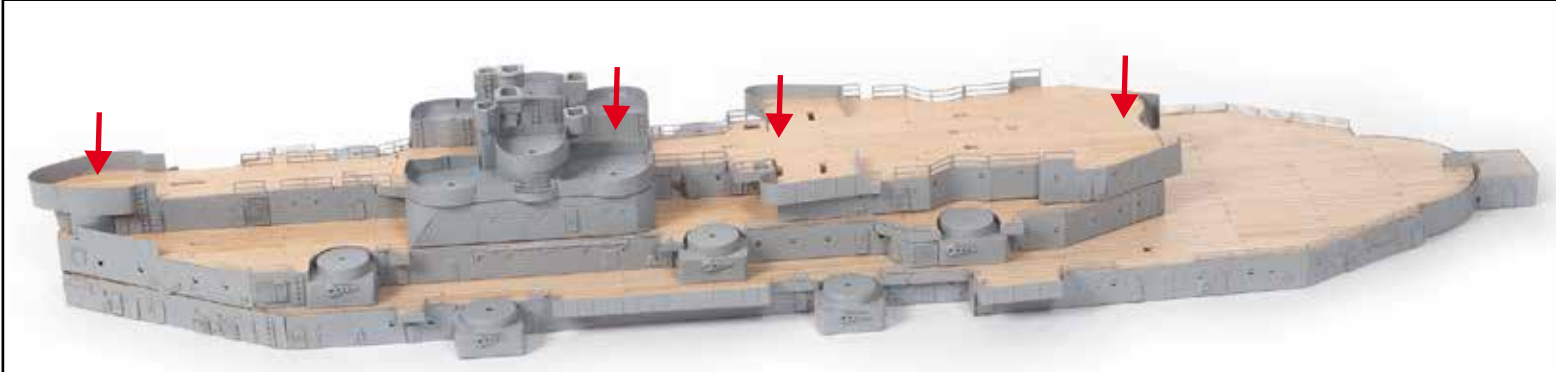

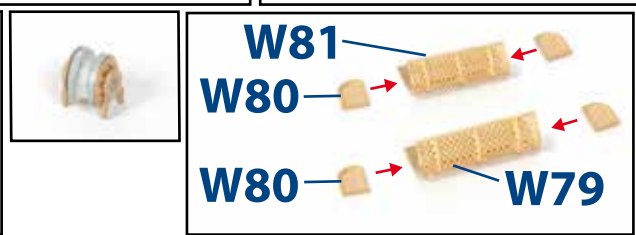
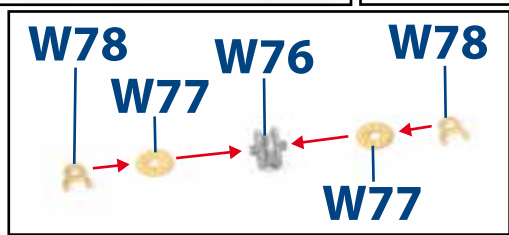
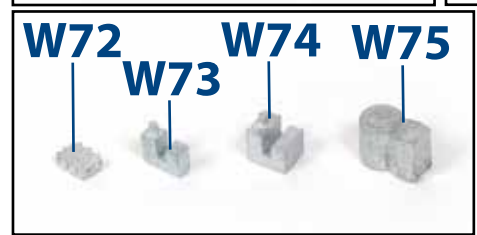
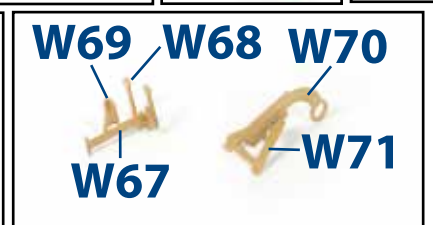
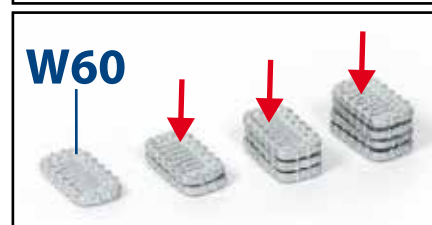
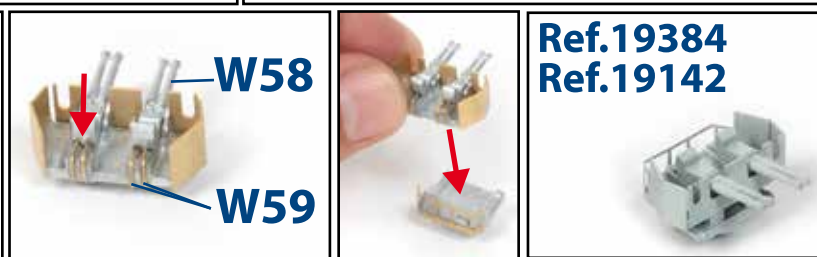
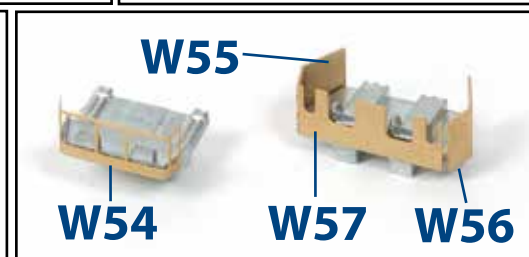
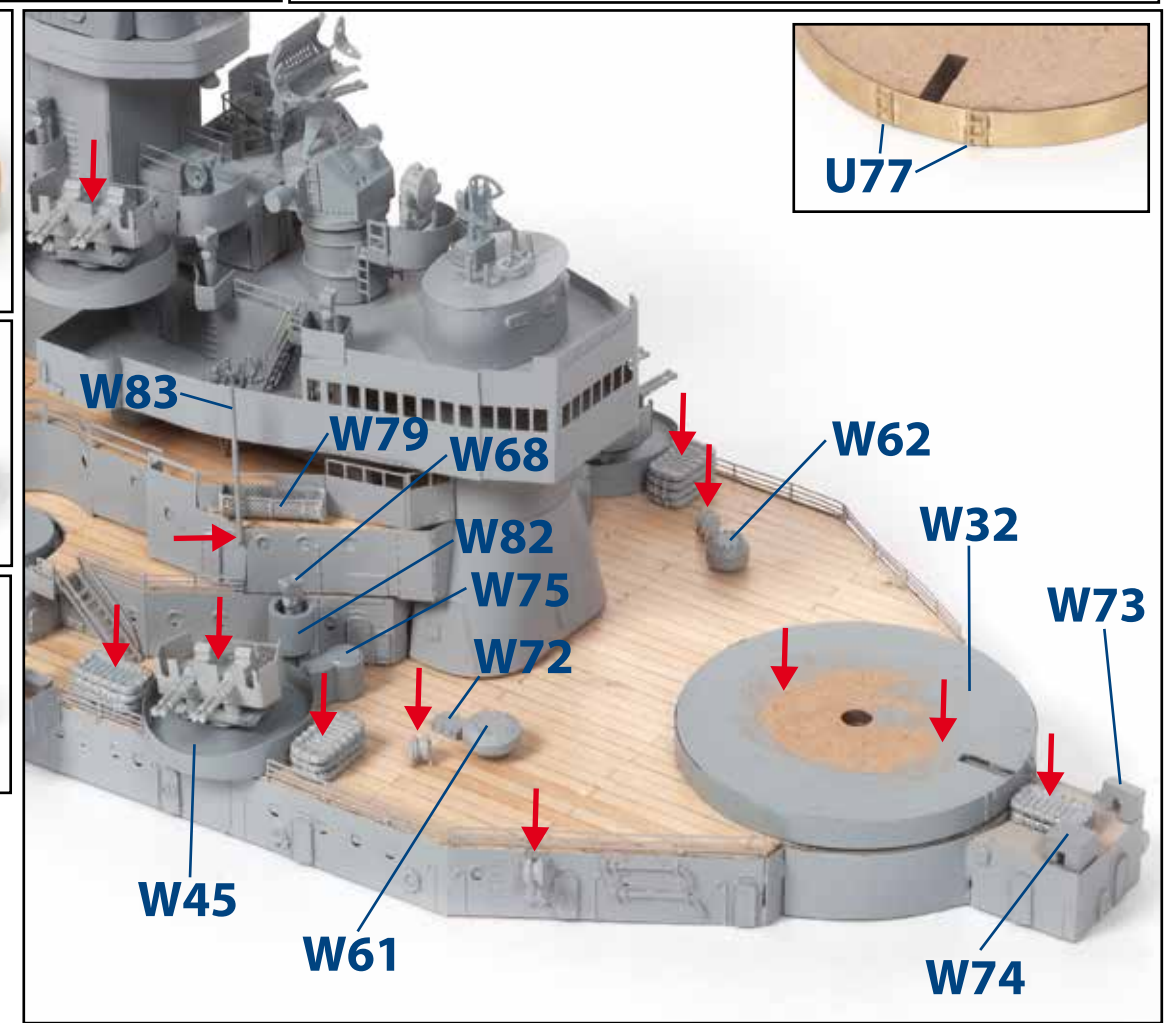
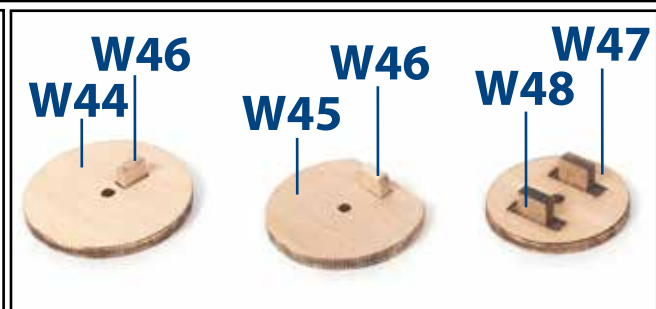
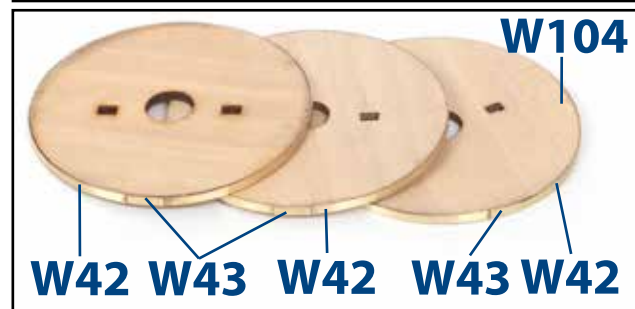
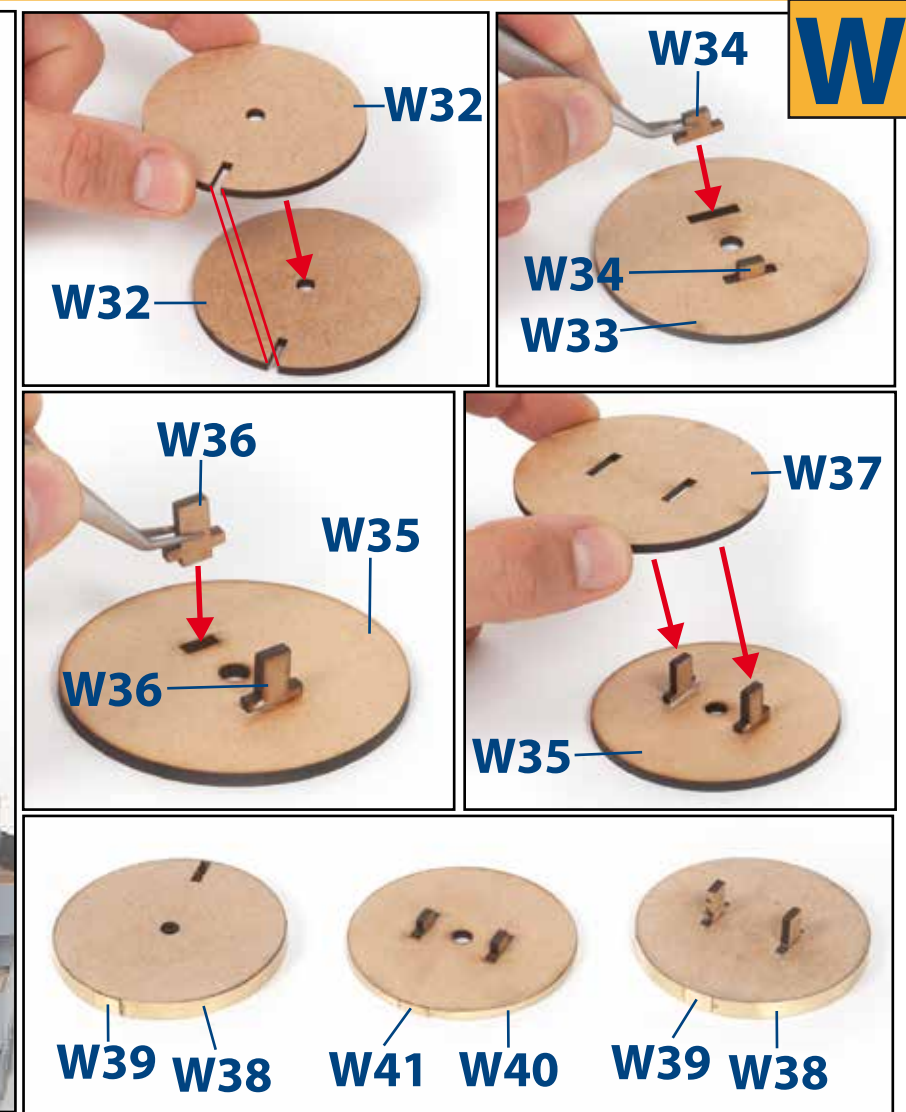
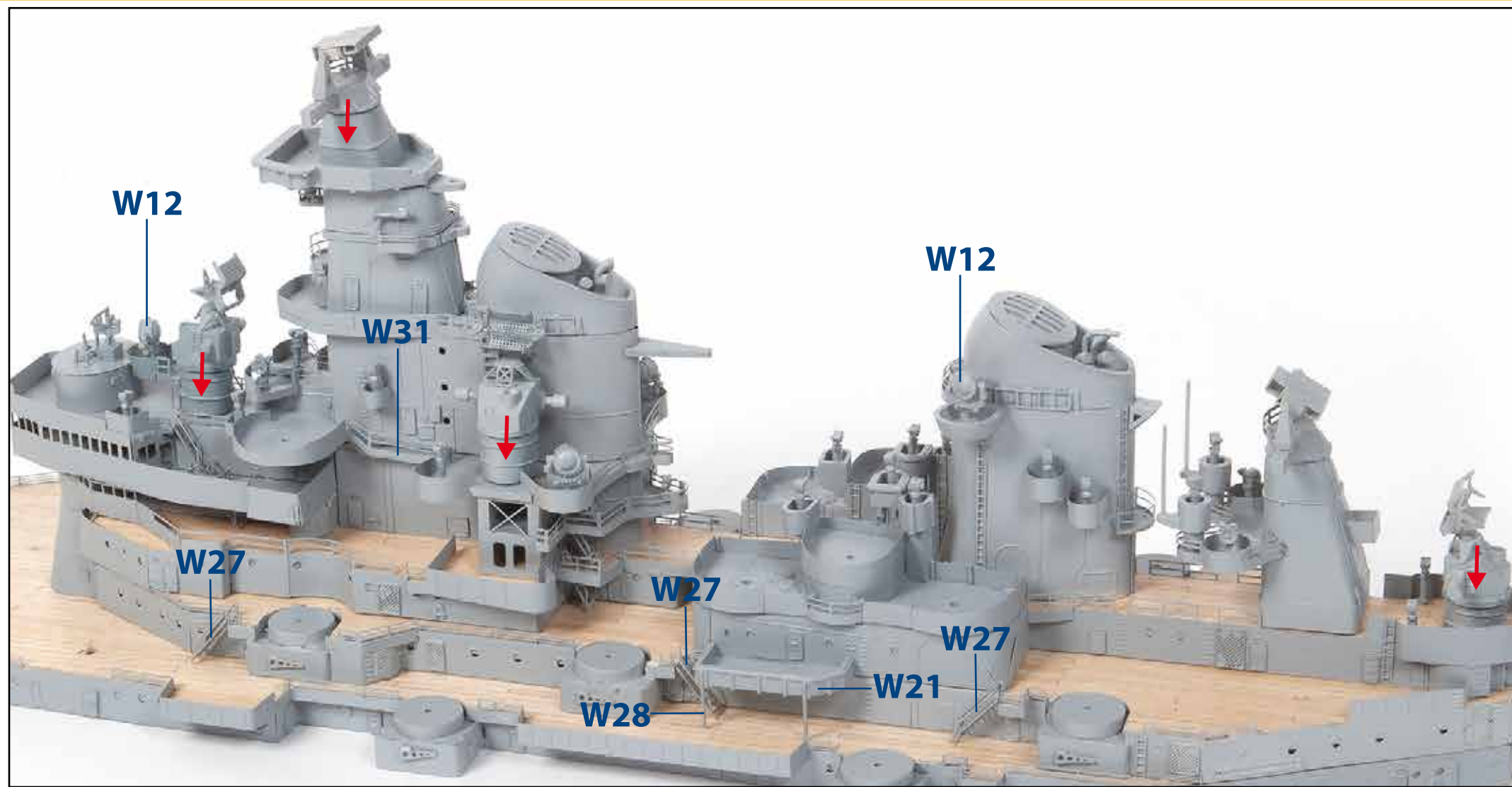

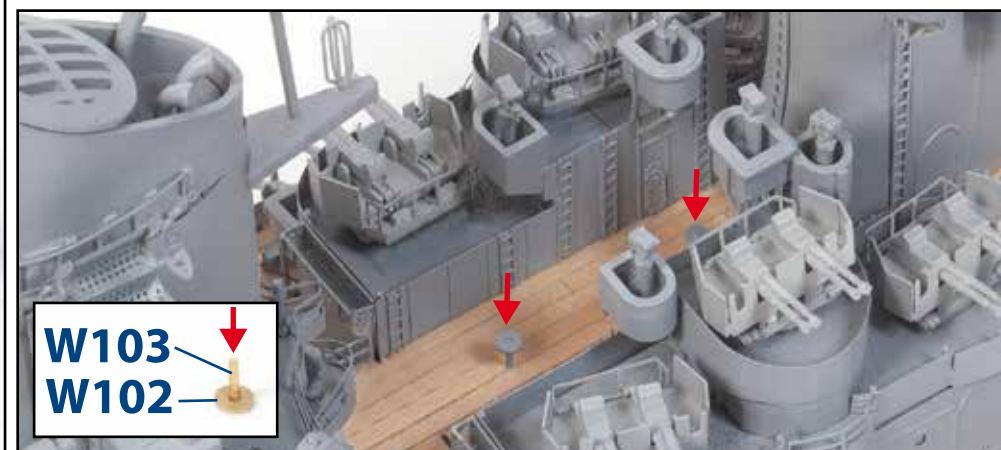
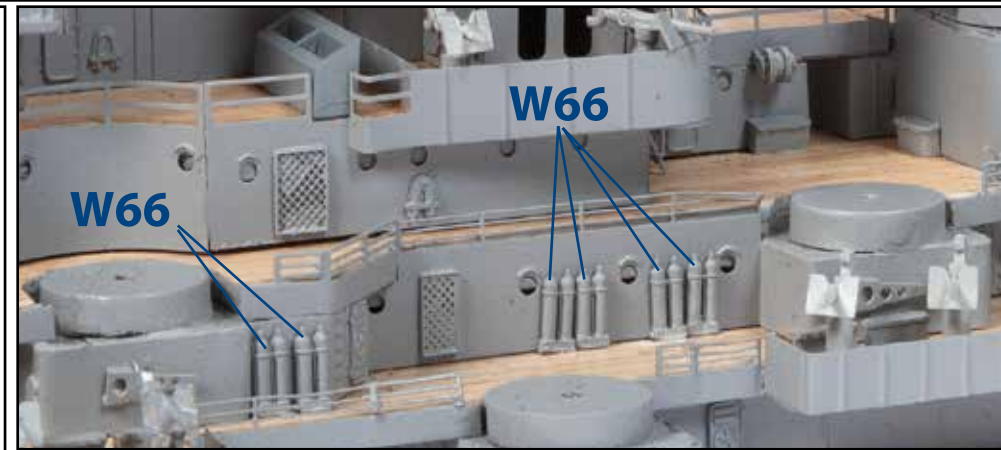
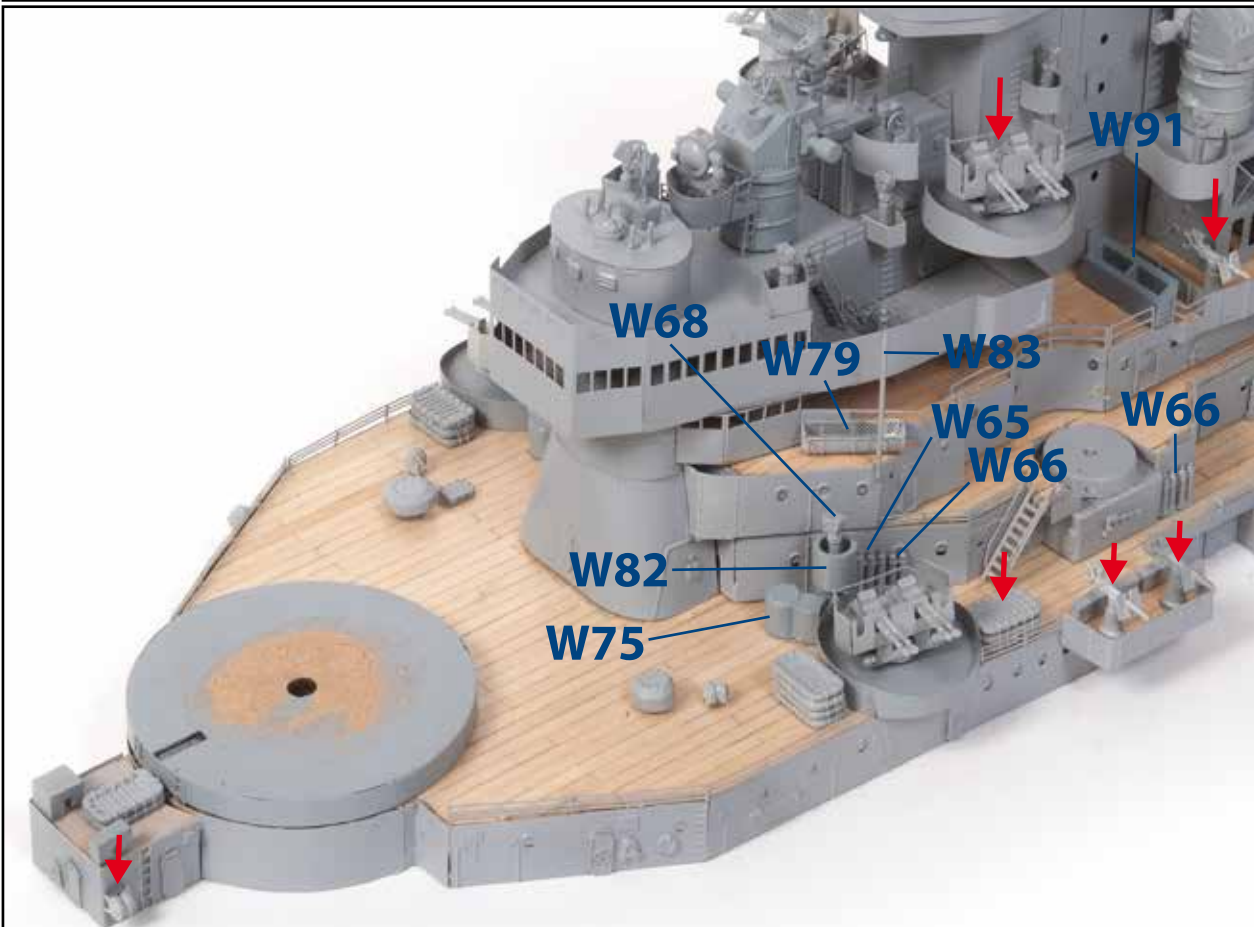
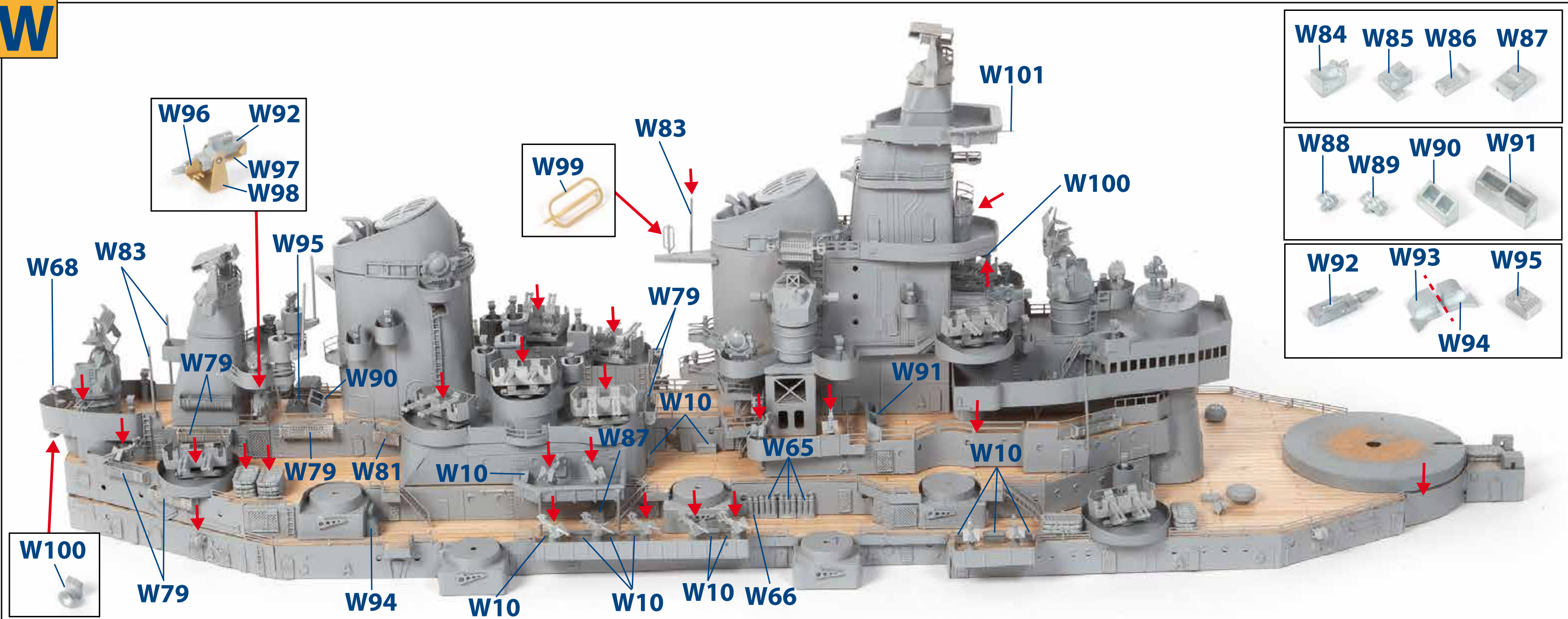

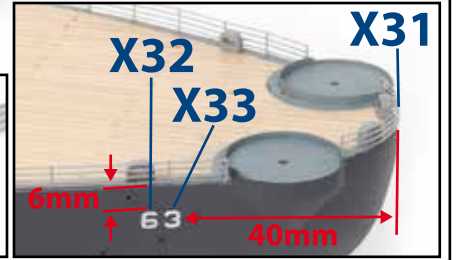
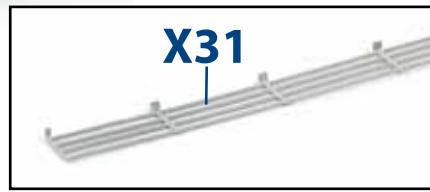
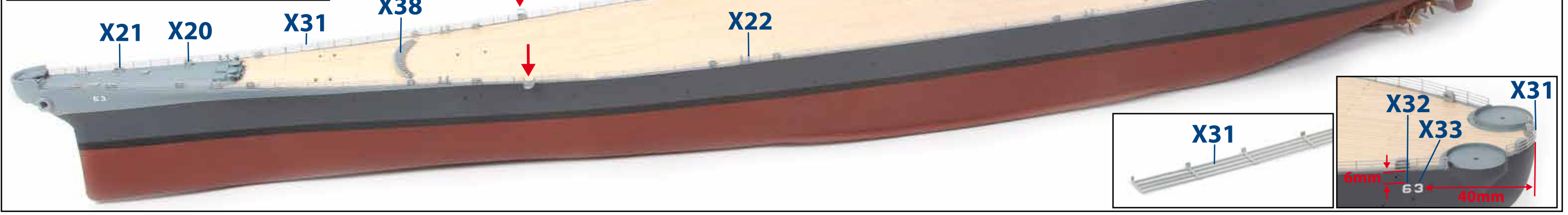
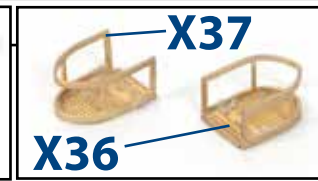
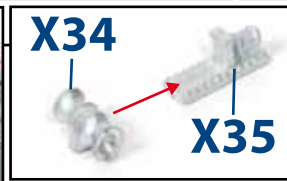
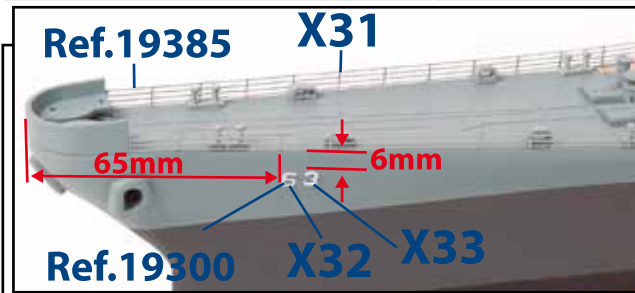
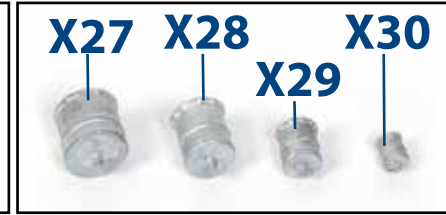
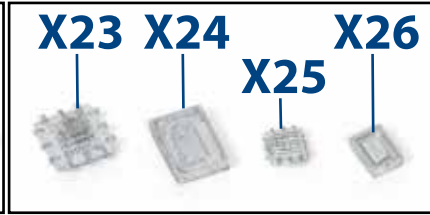
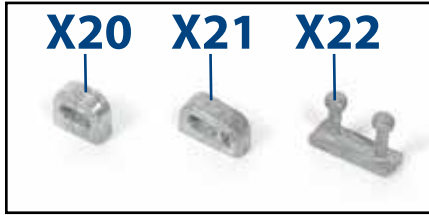
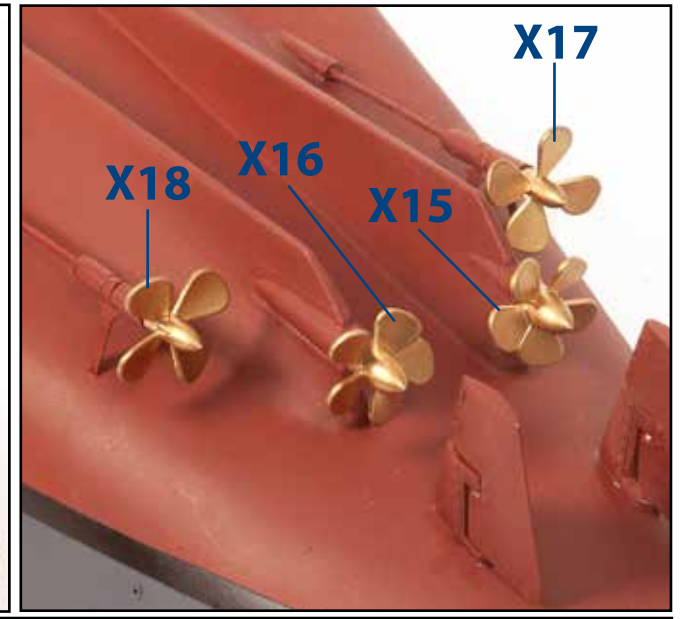
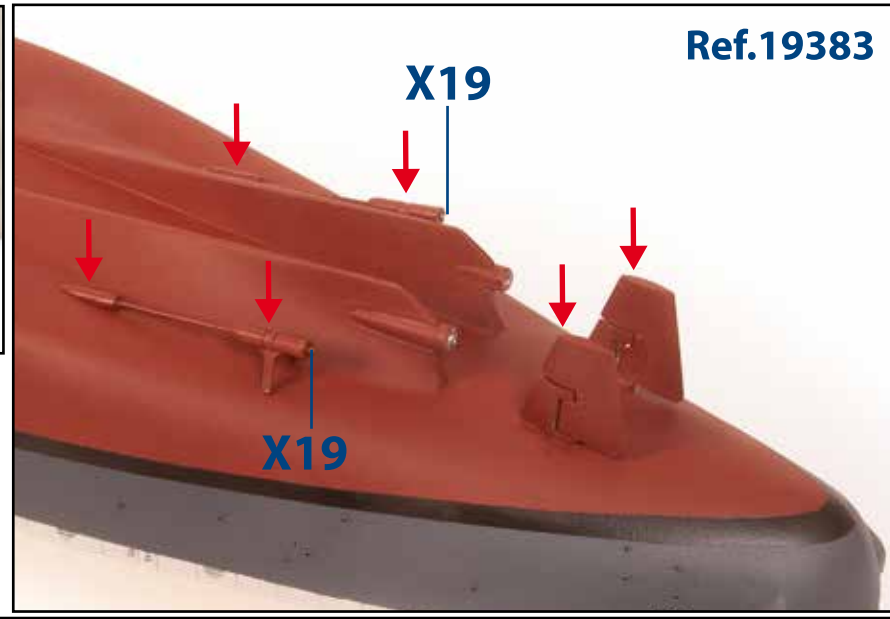
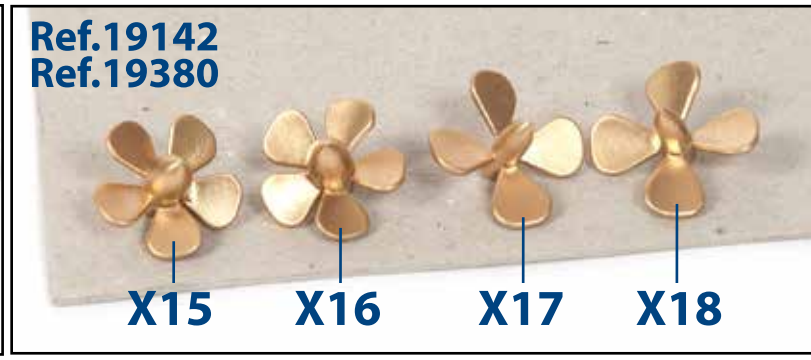
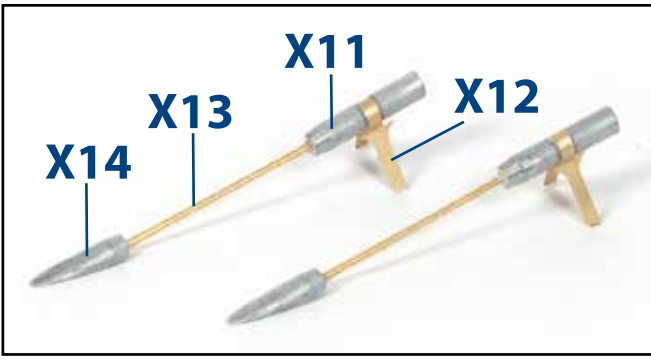
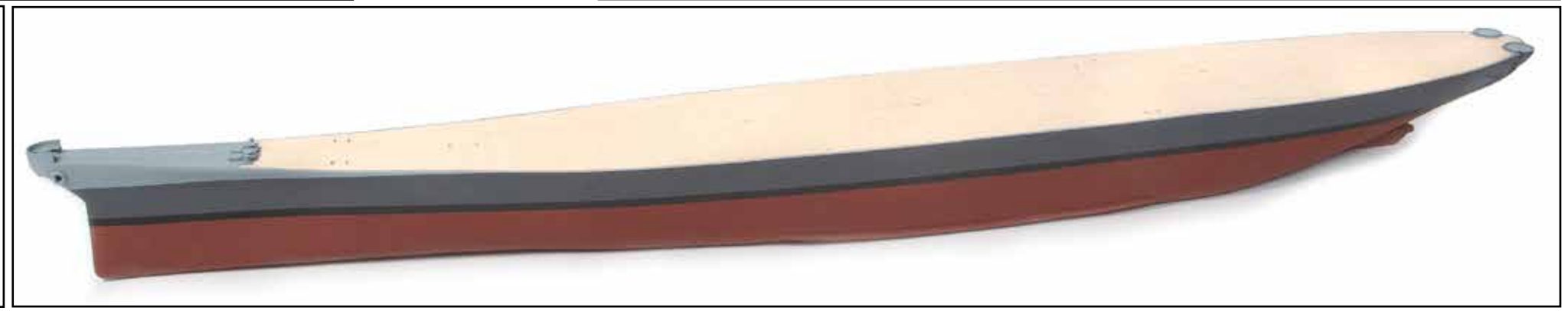
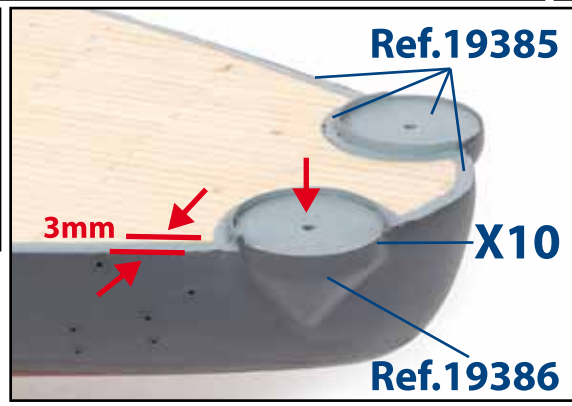
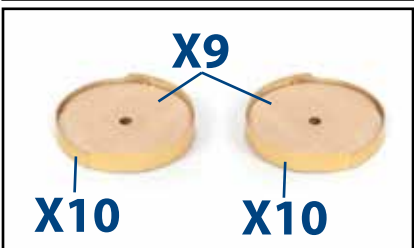
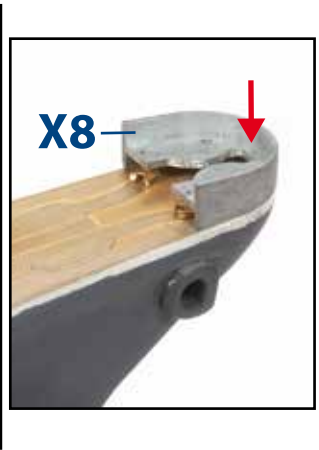
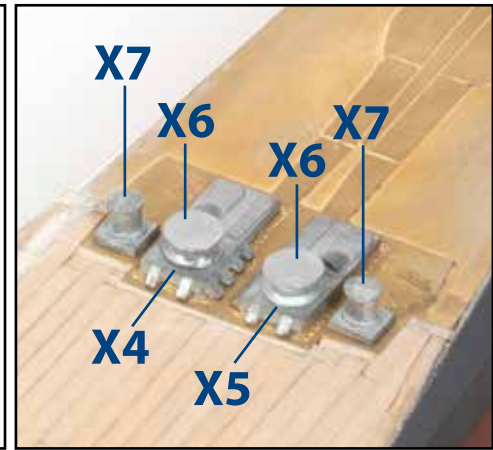
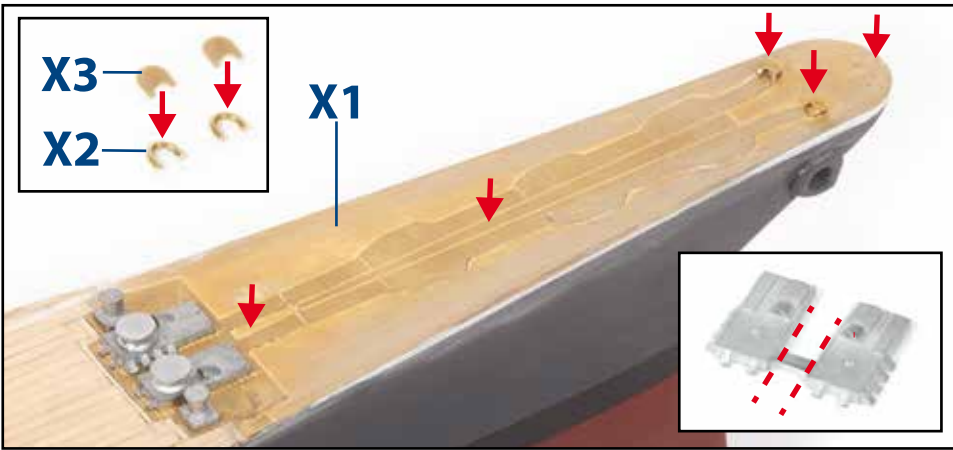

X

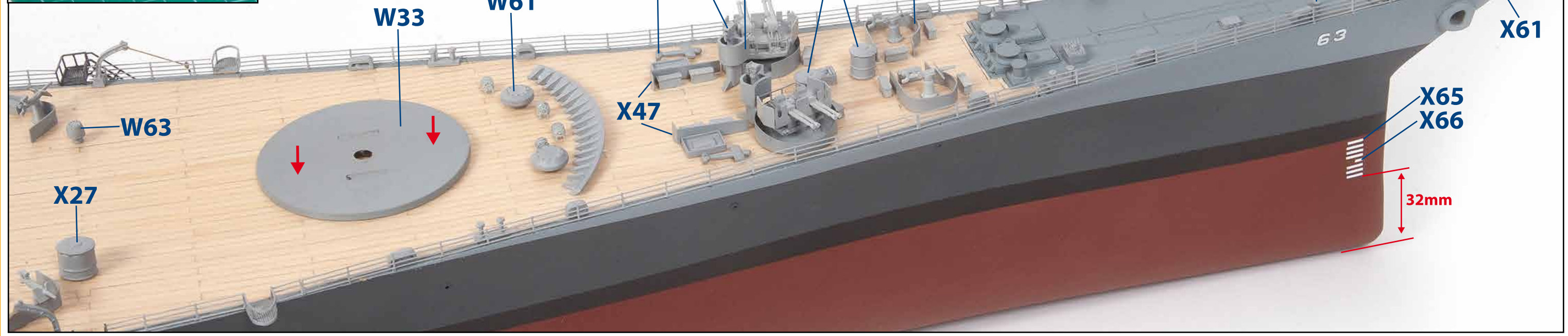
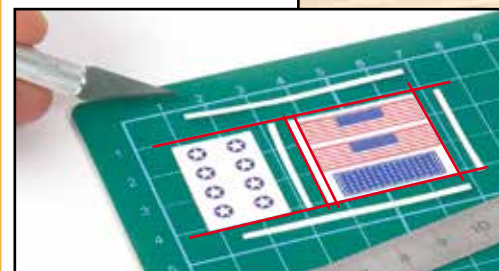
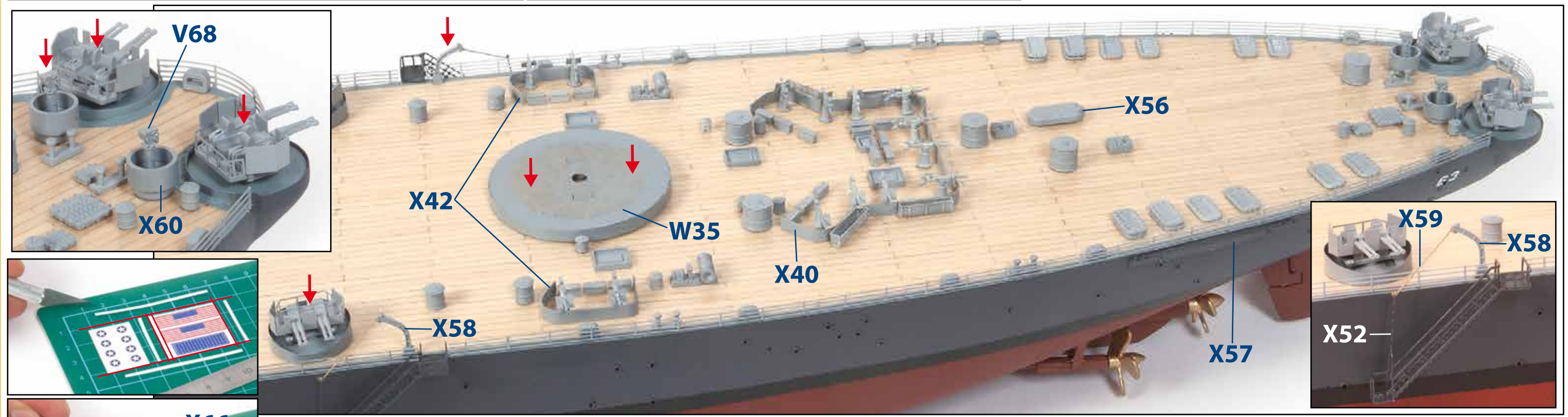
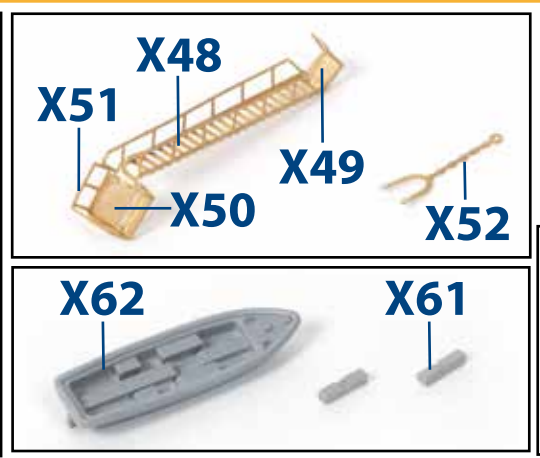
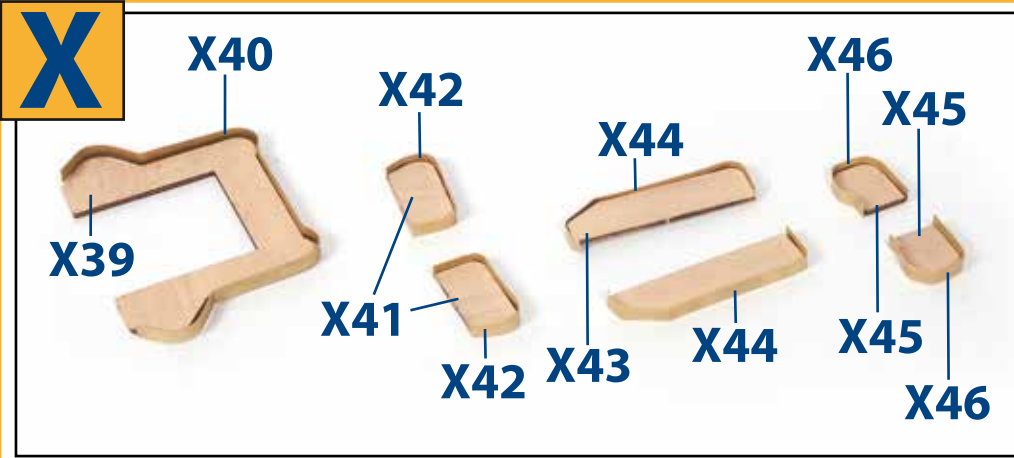

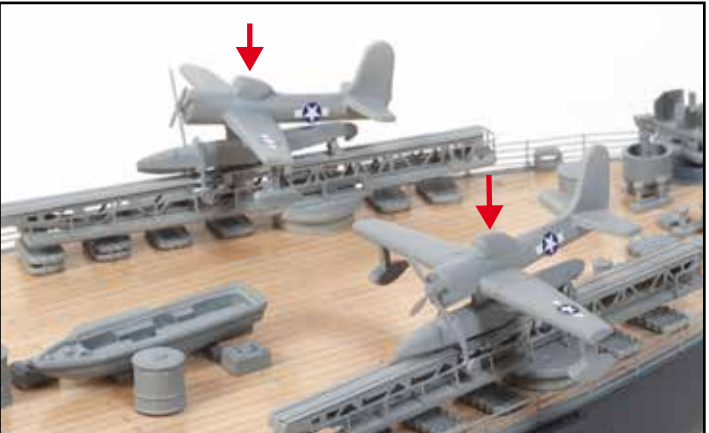
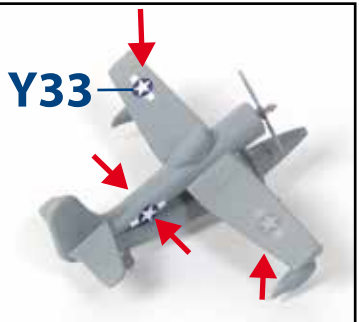
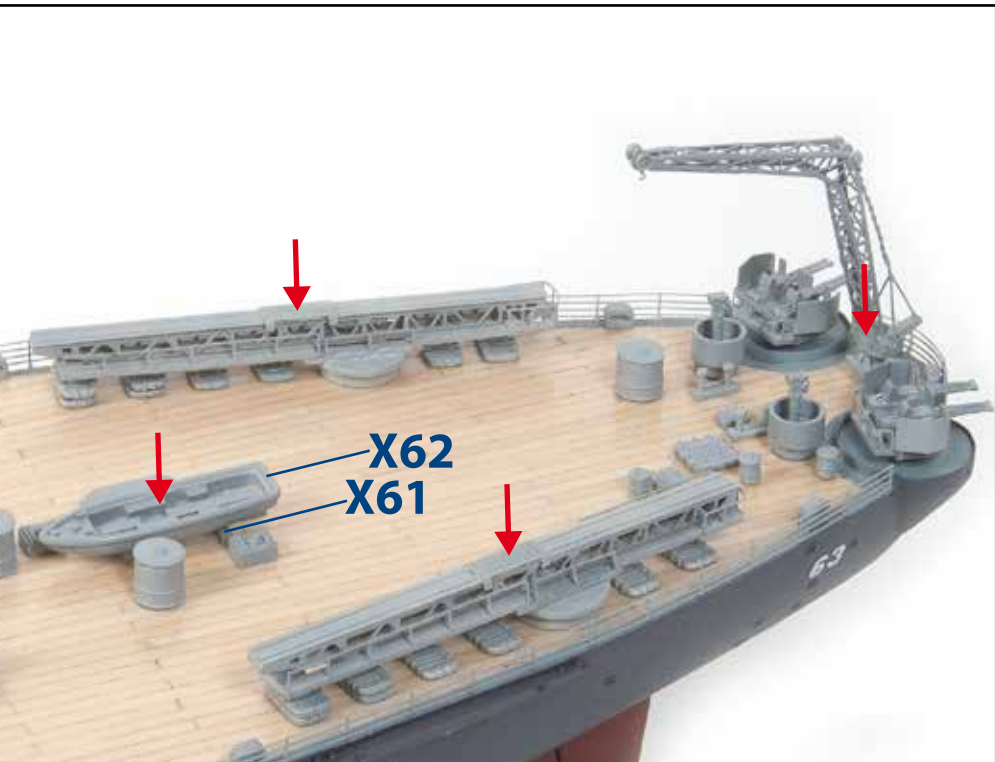
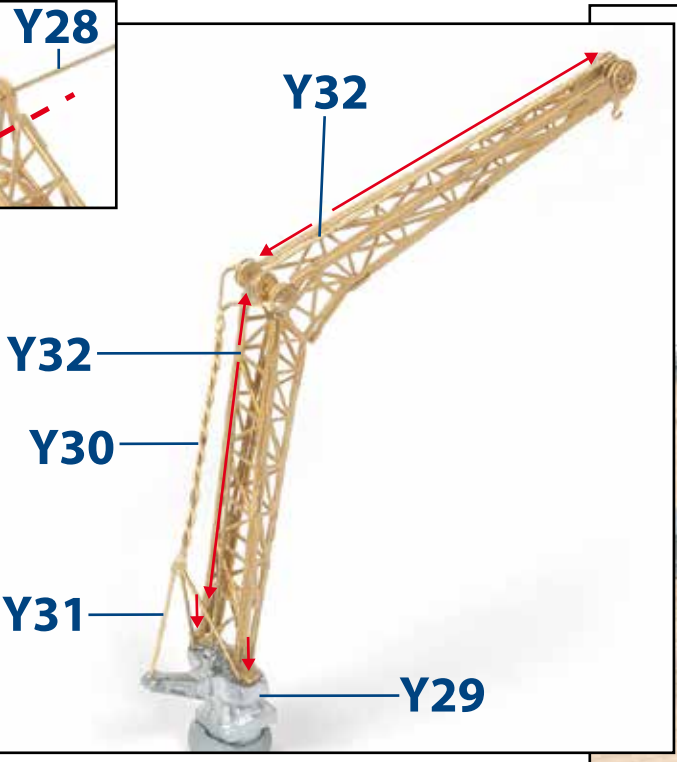
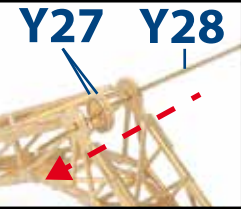
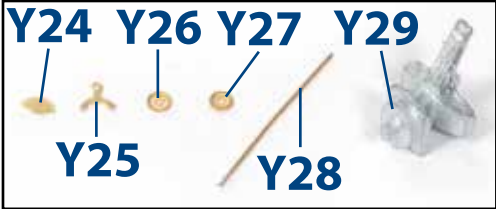
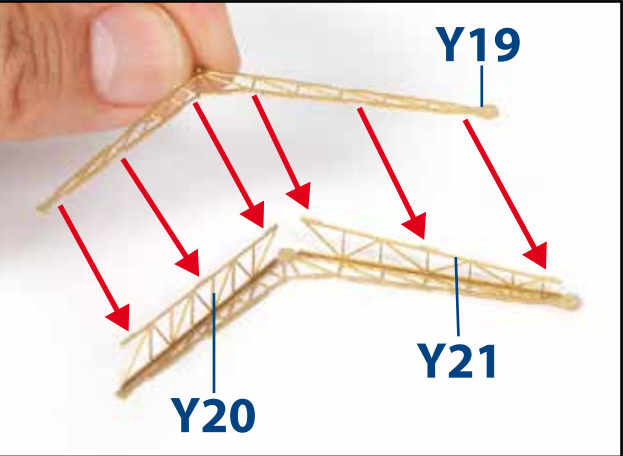
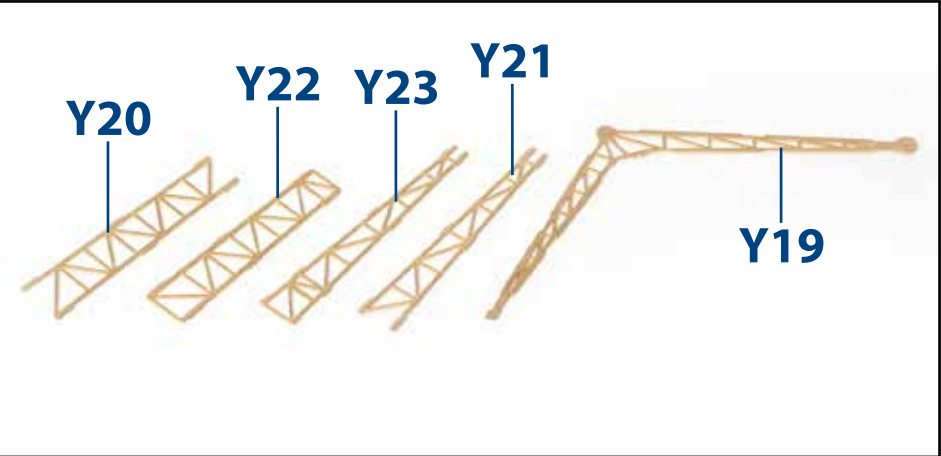
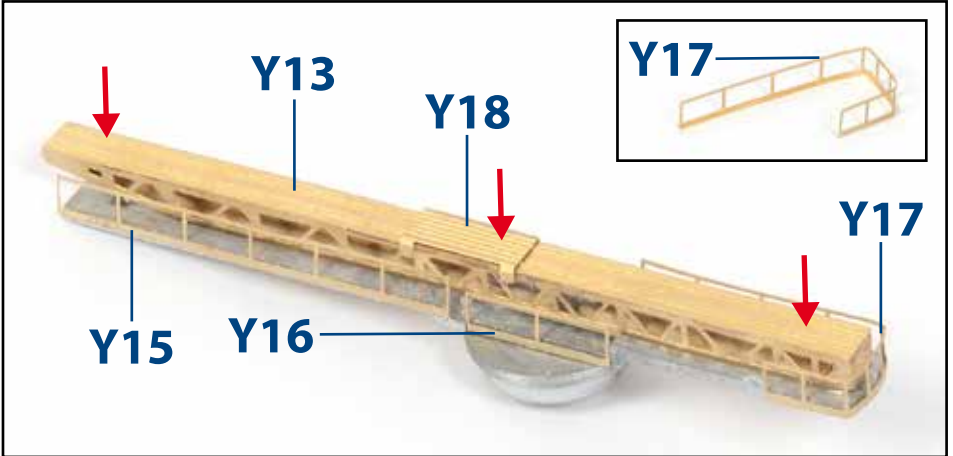
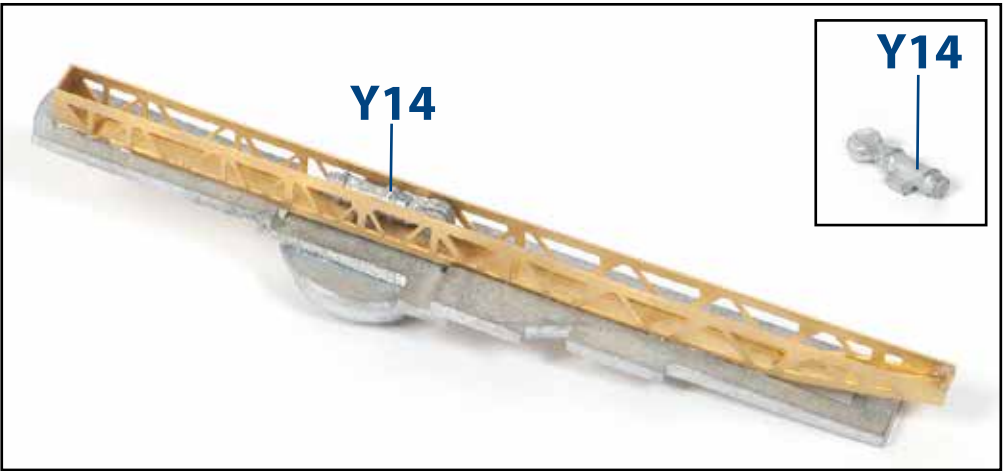
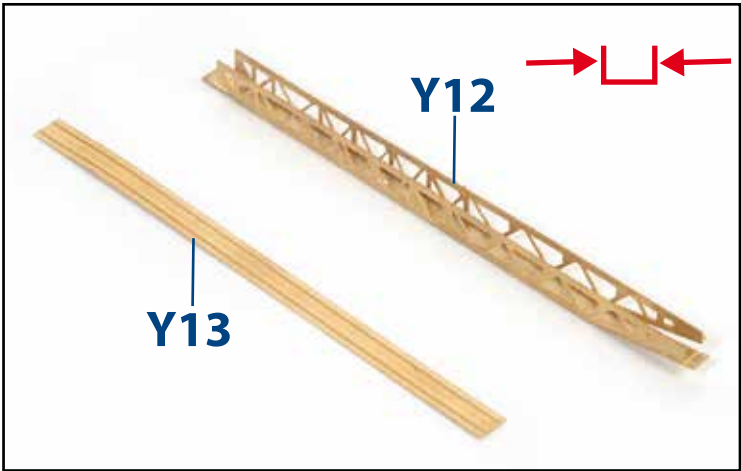
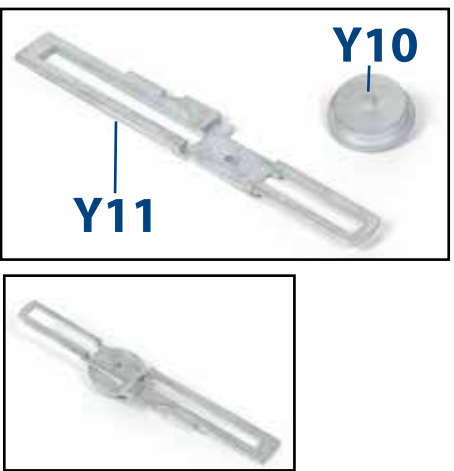
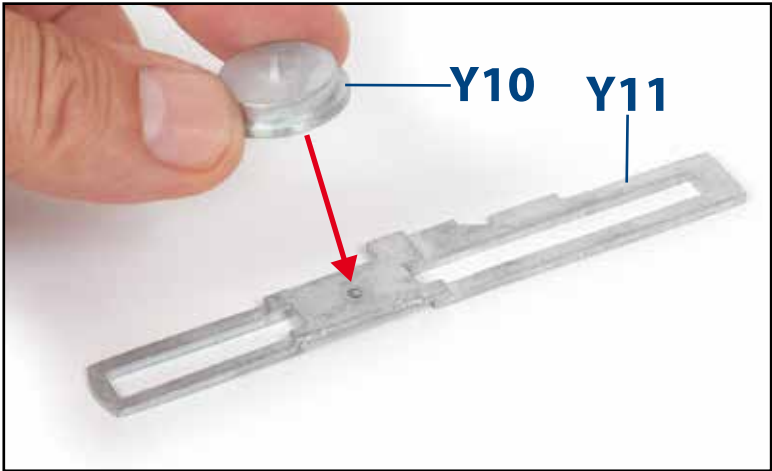
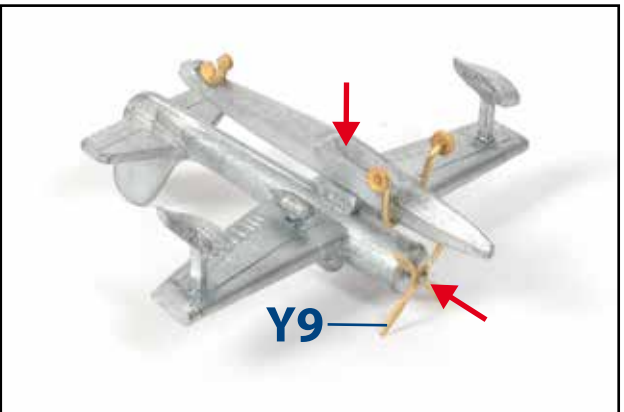
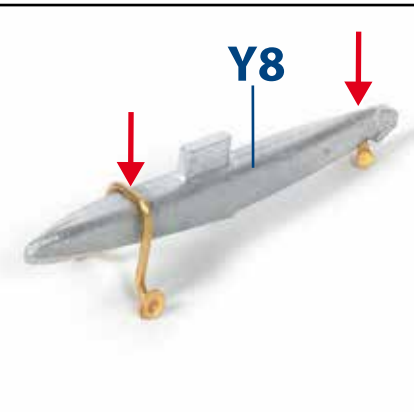
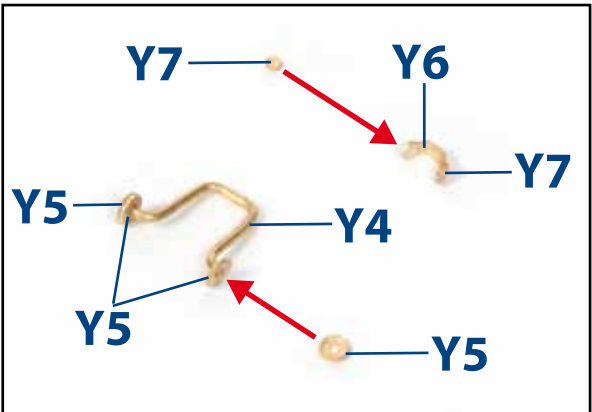
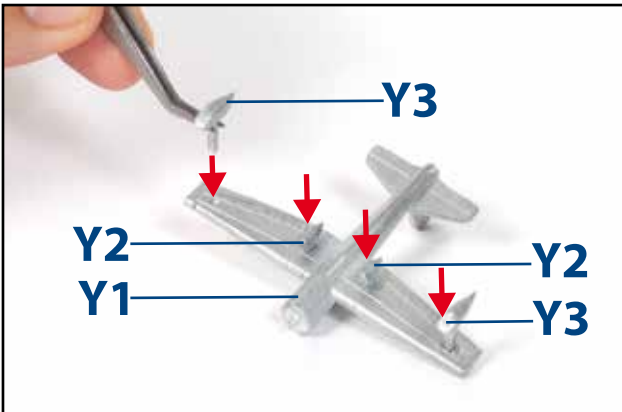

Y

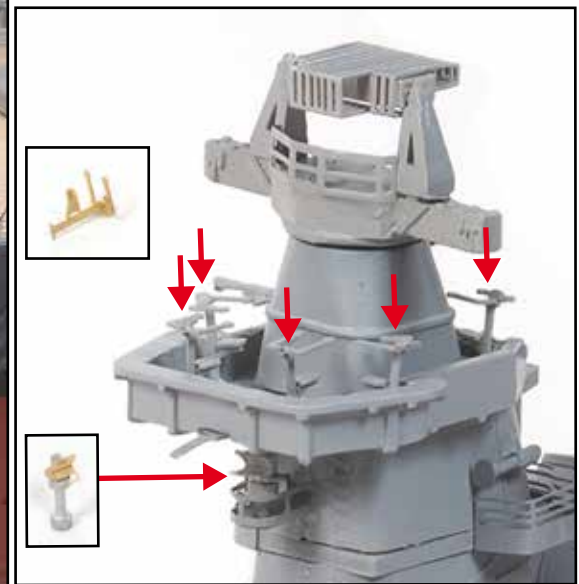
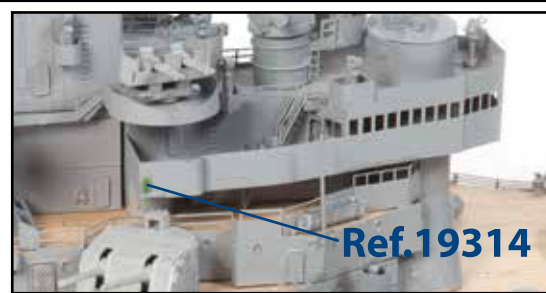
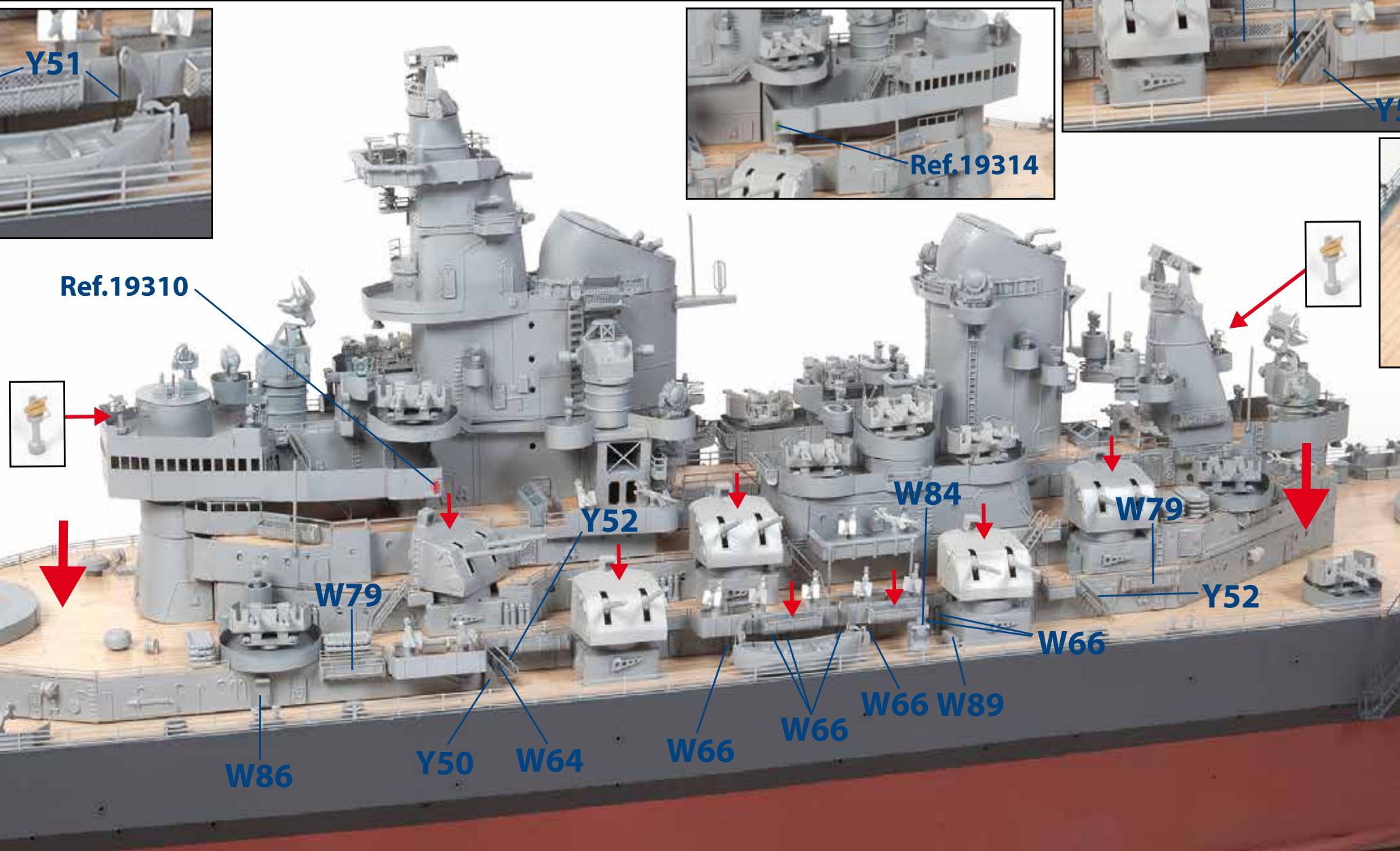
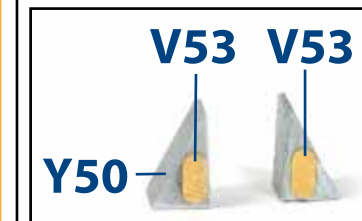
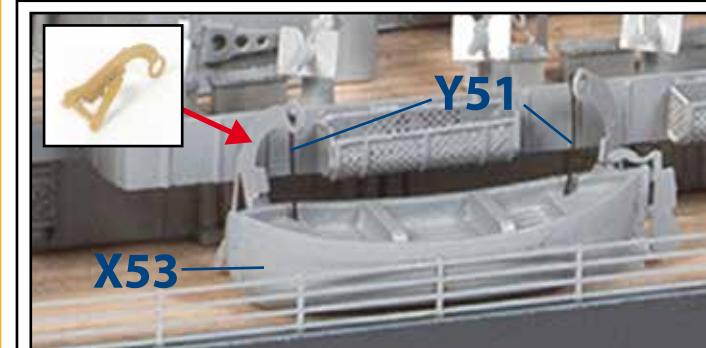
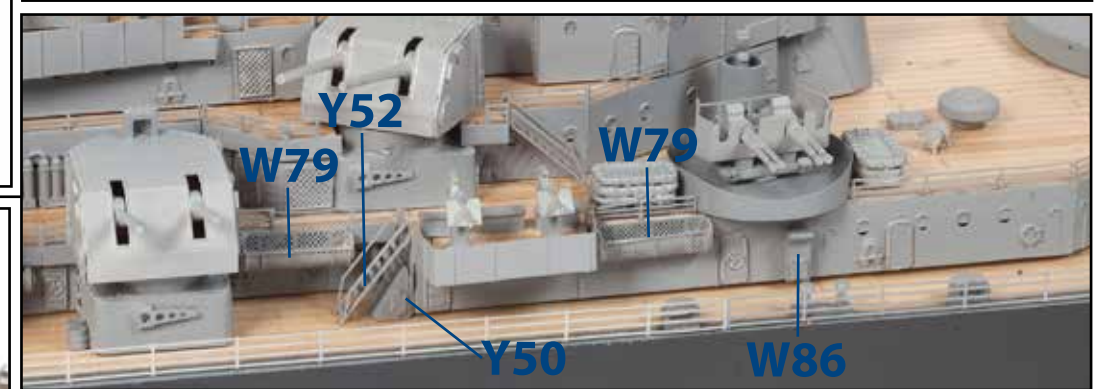
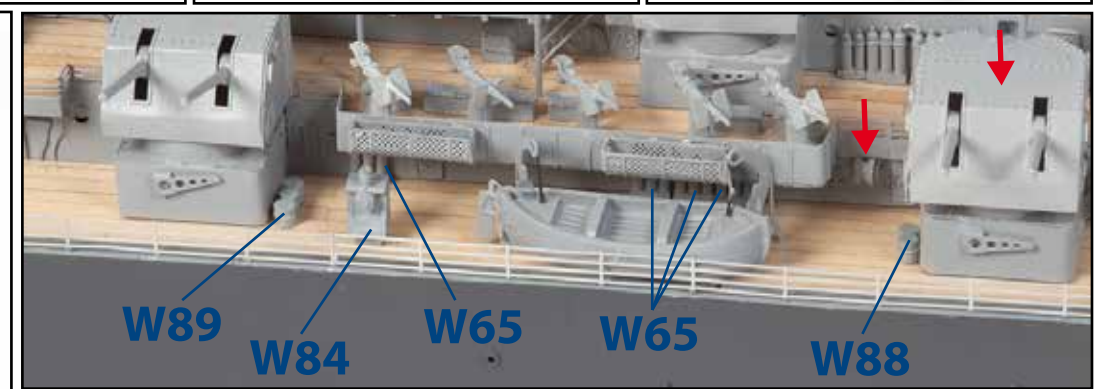
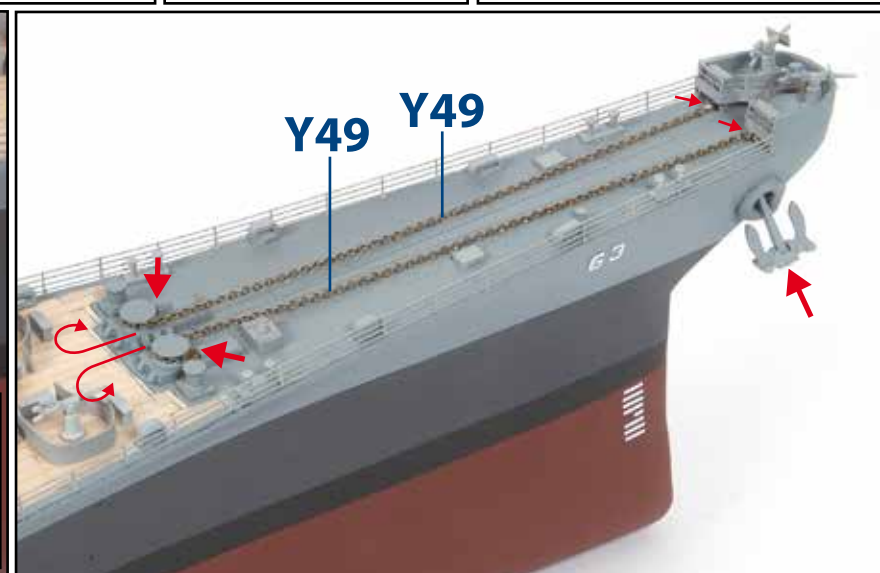
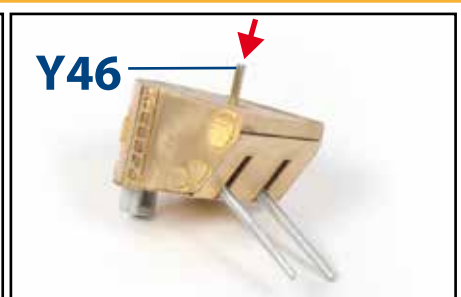
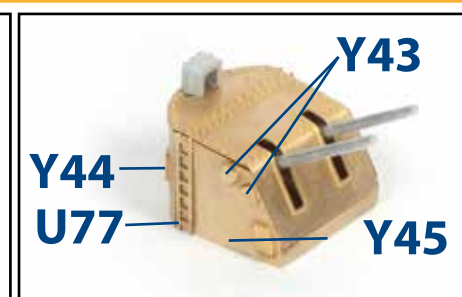
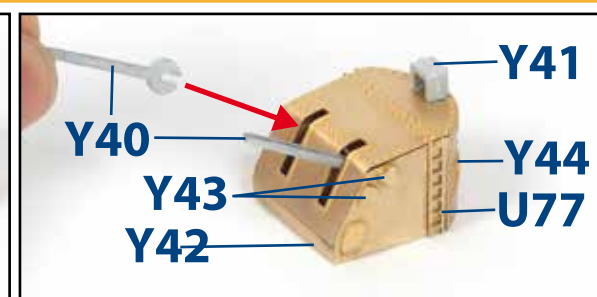
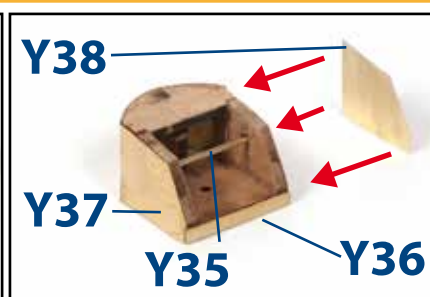
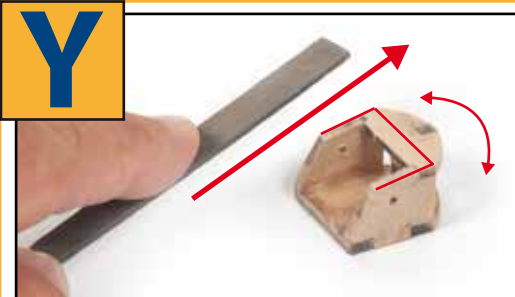

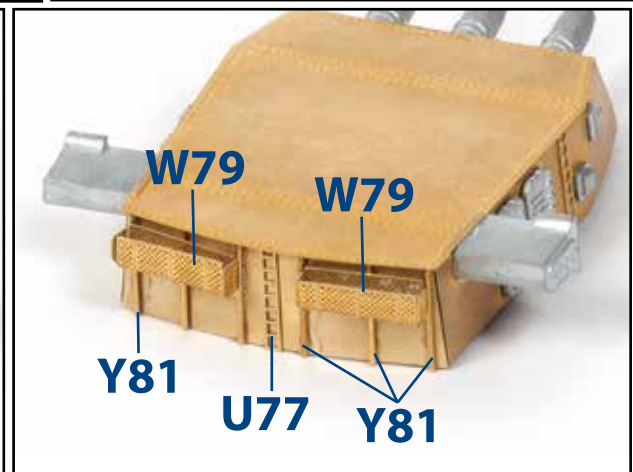
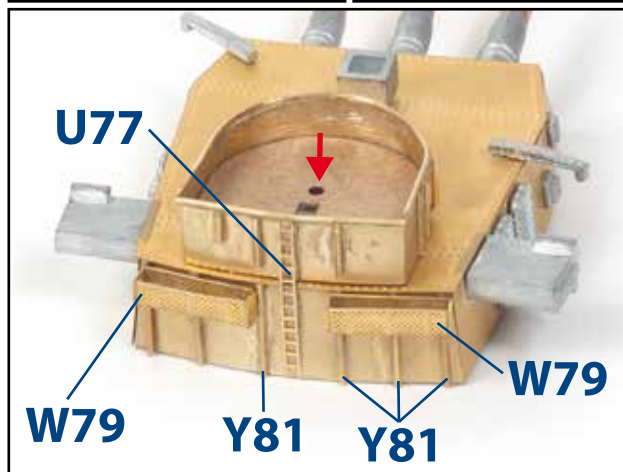
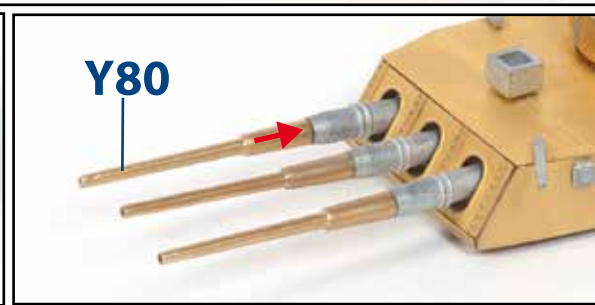
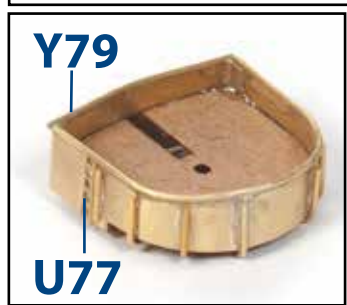
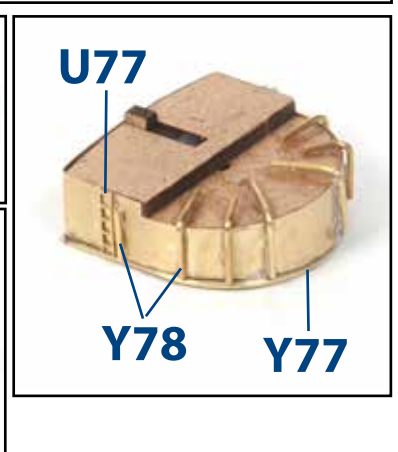
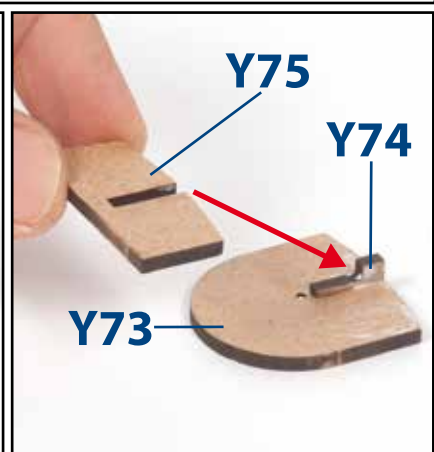
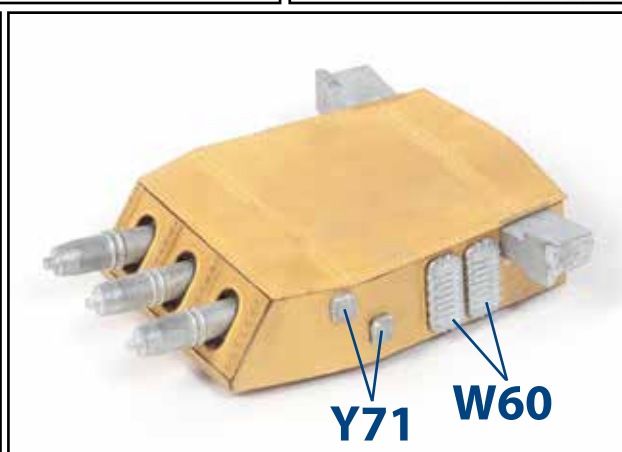
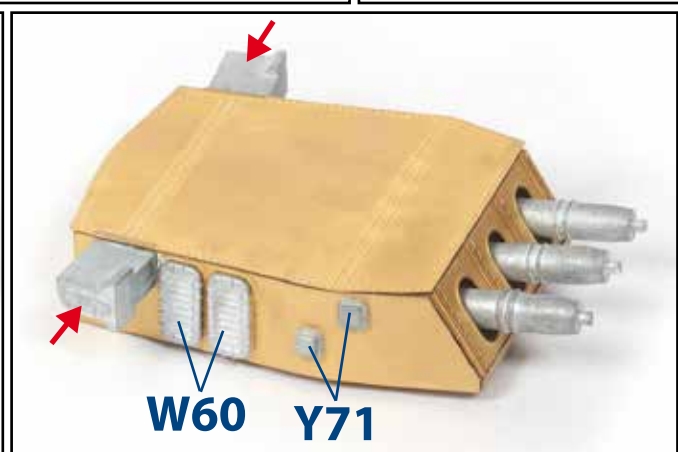
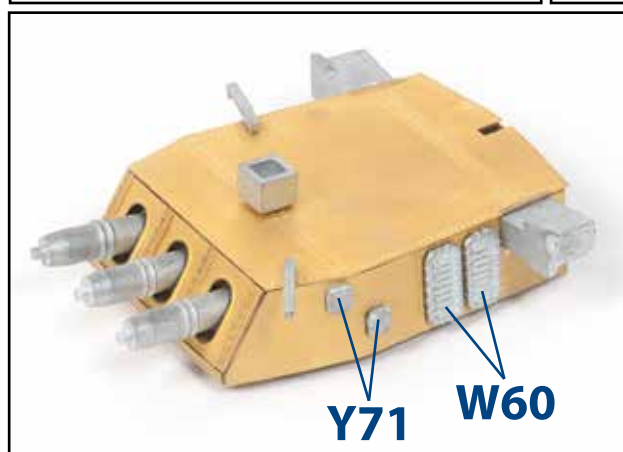
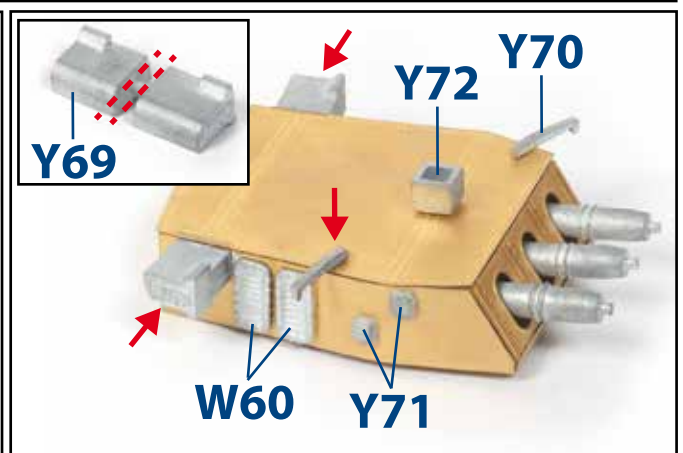
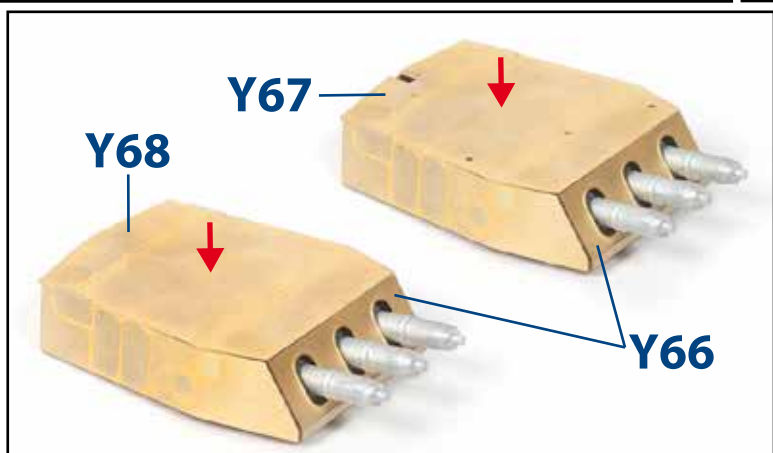
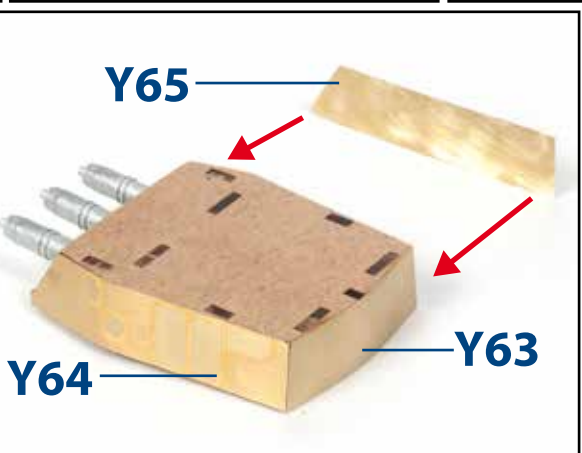
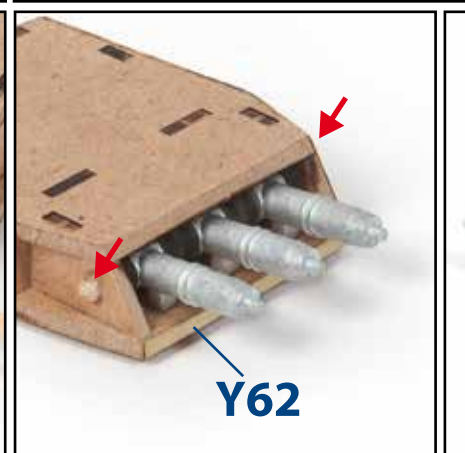
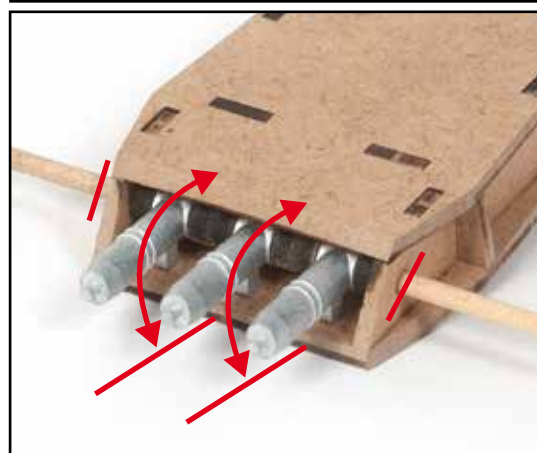
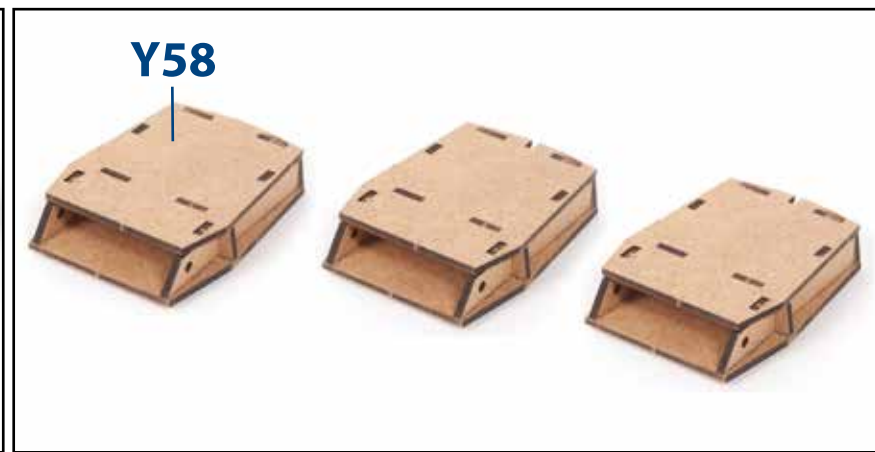
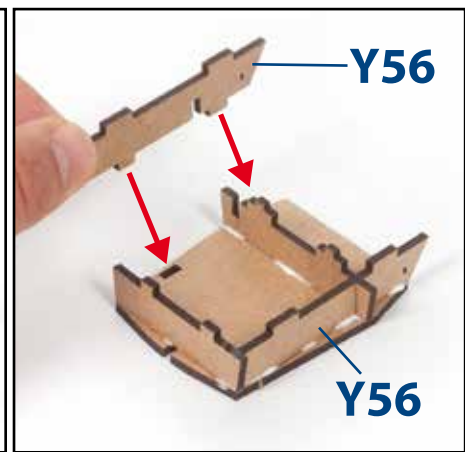
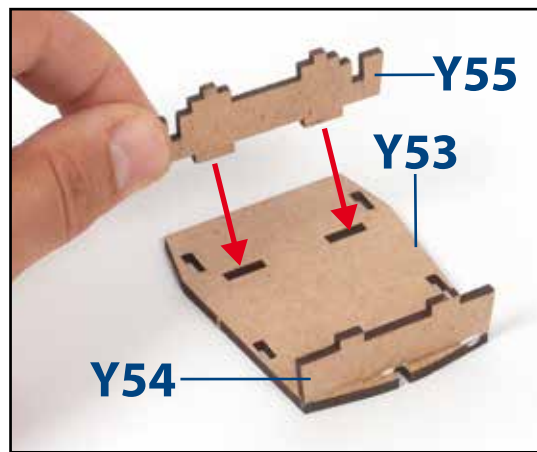

Ref.19384
Ref.19142

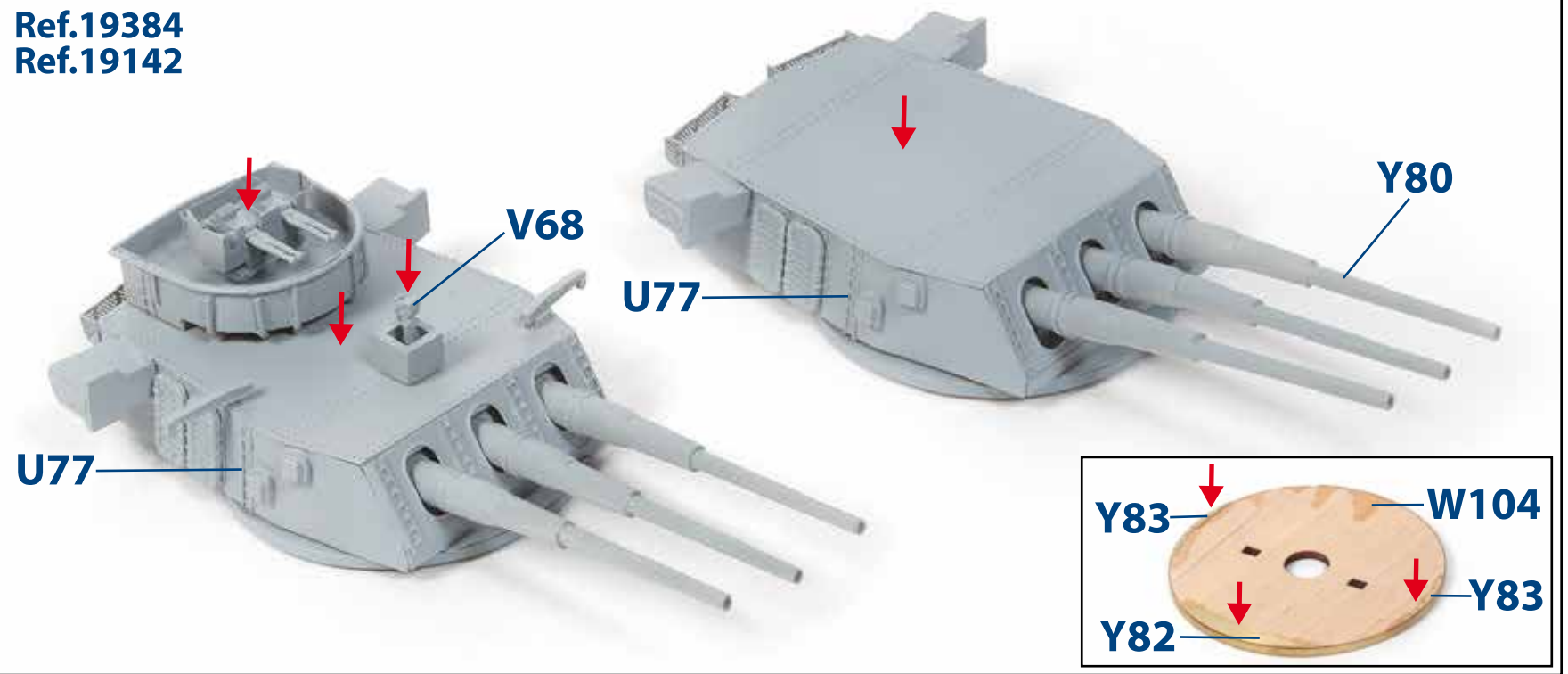

Z

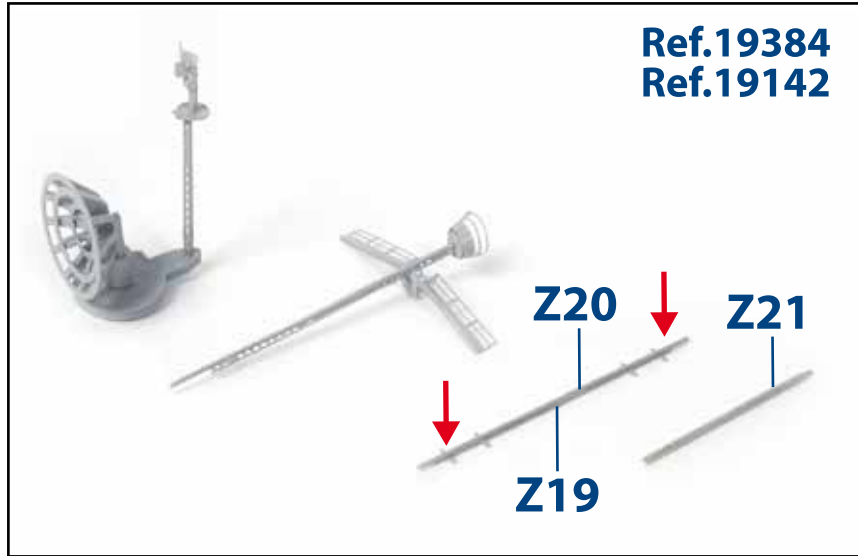
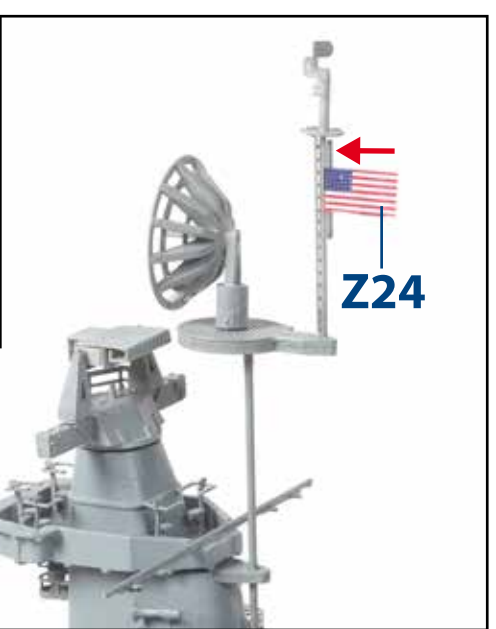
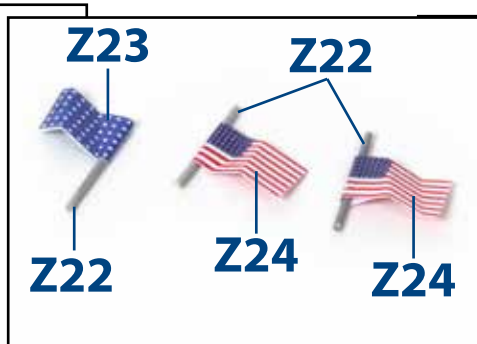
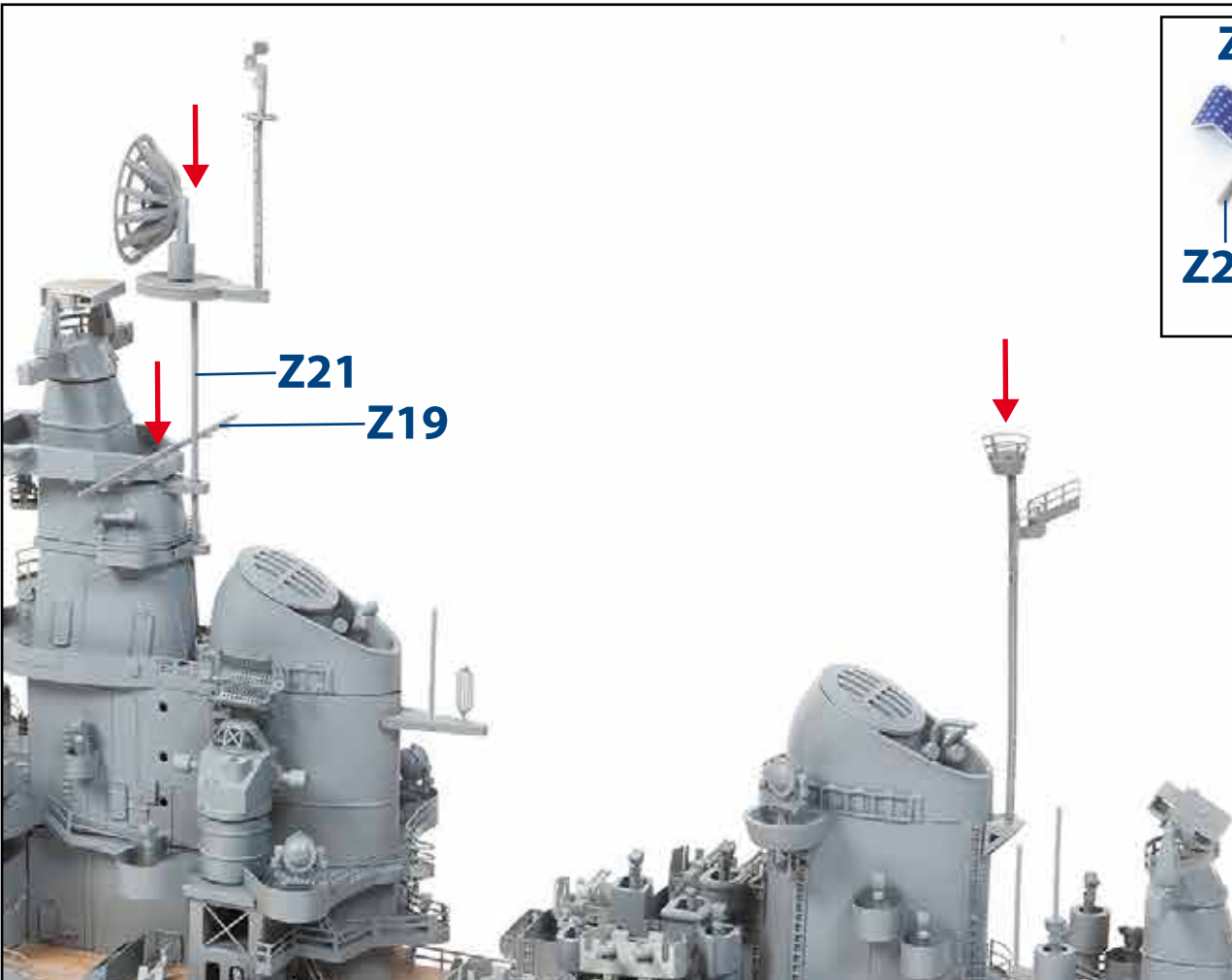
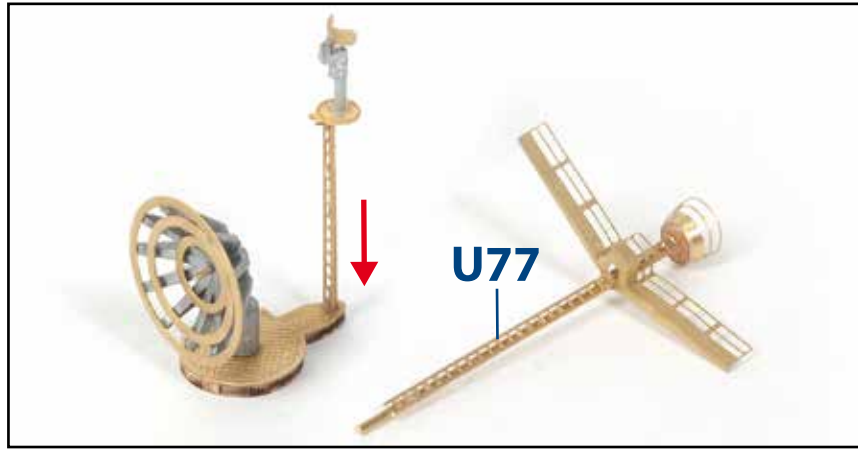
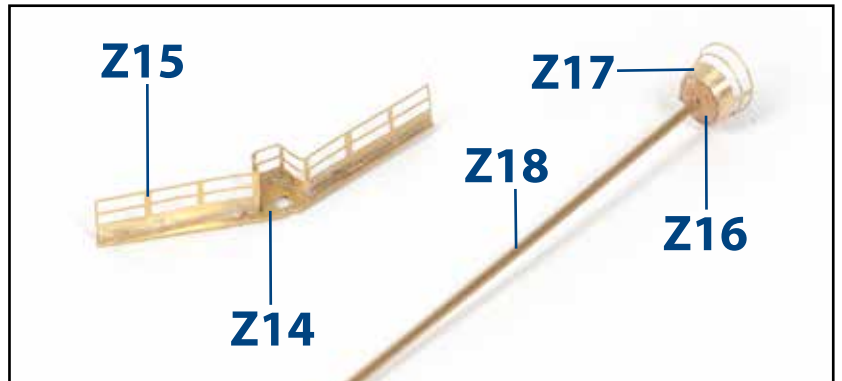
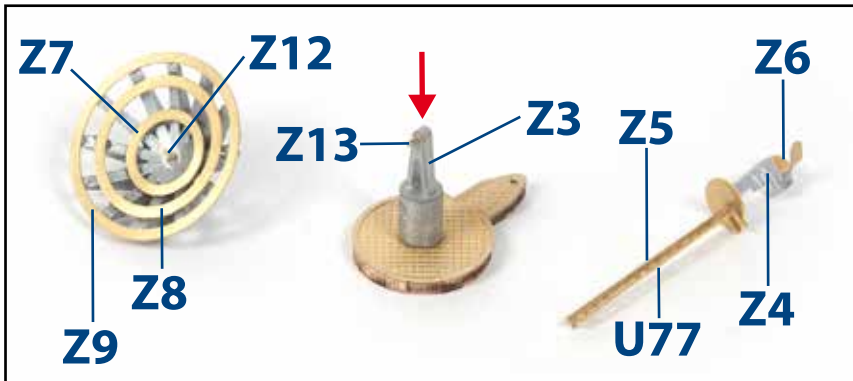
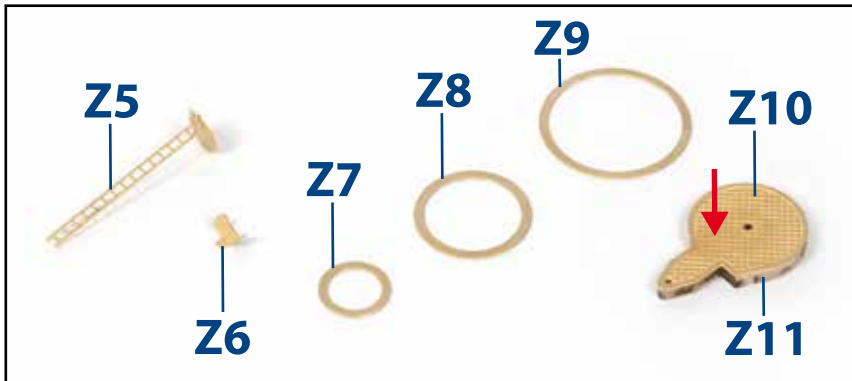
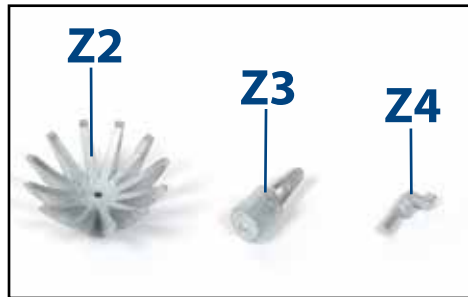
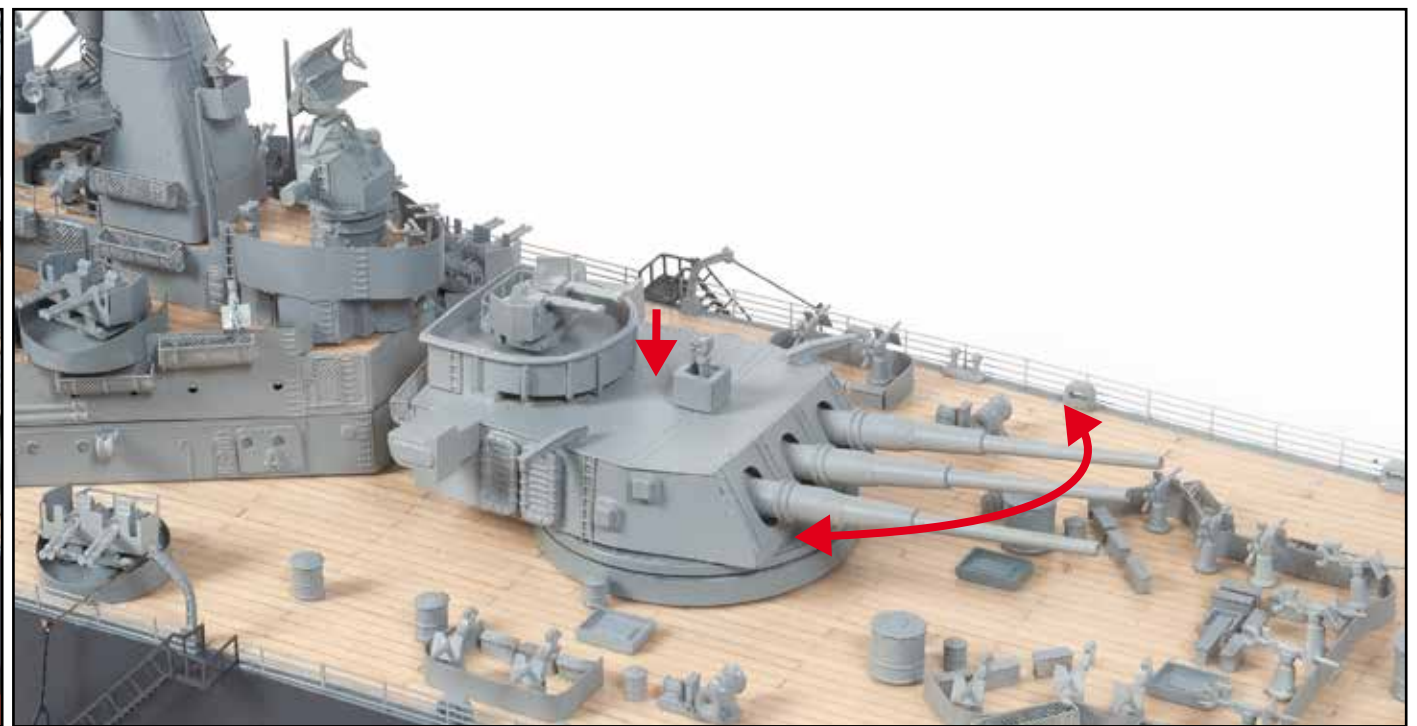
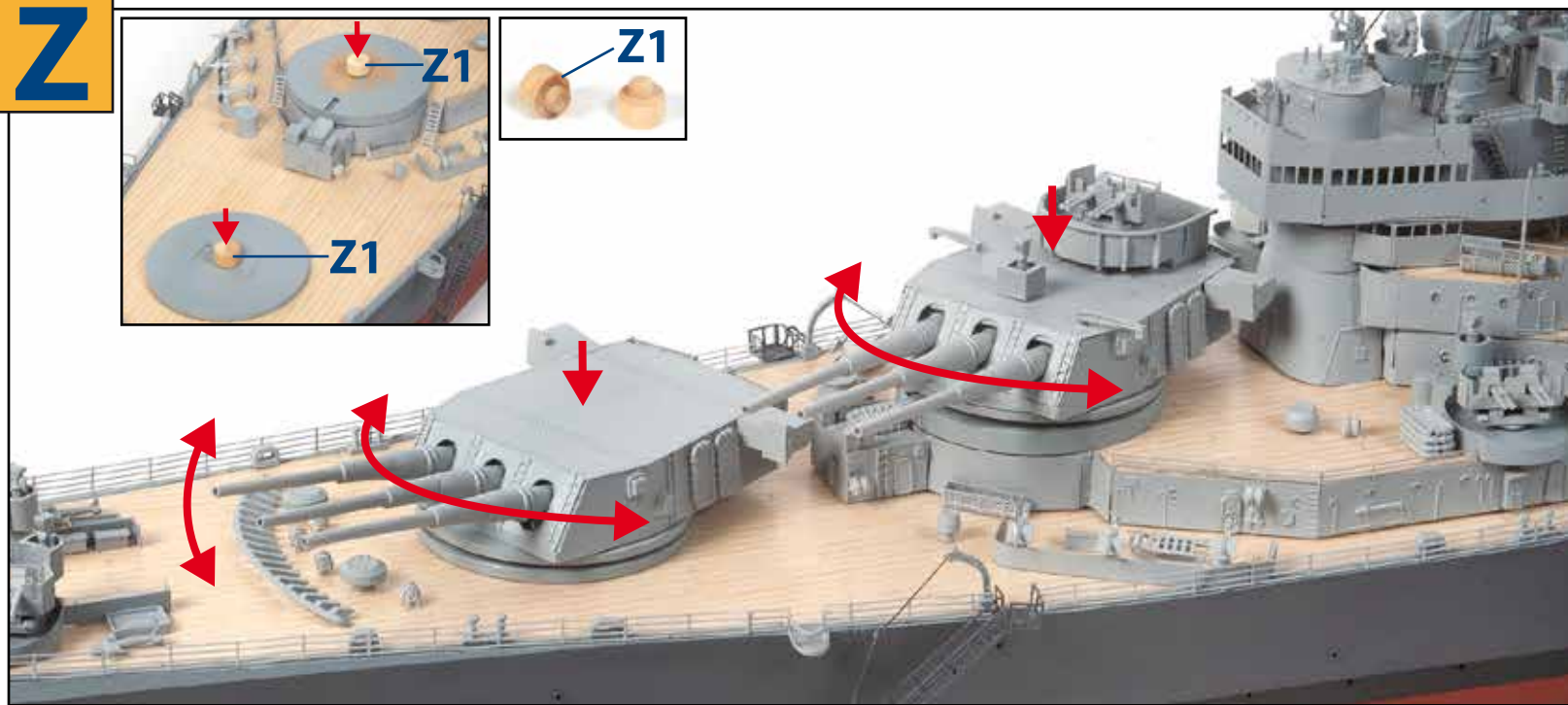
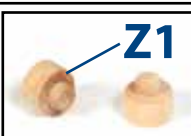
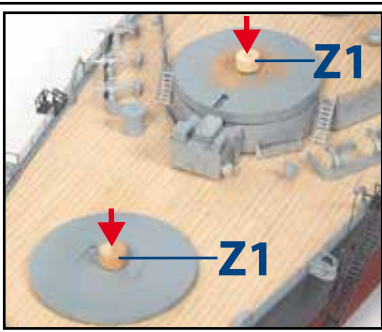

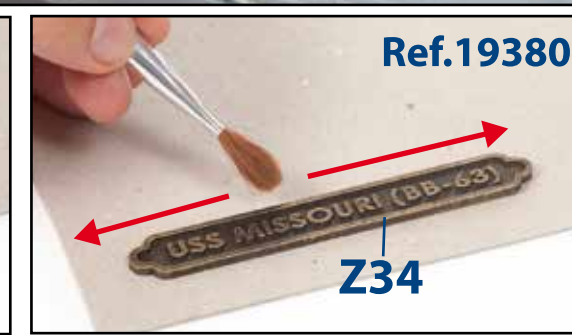
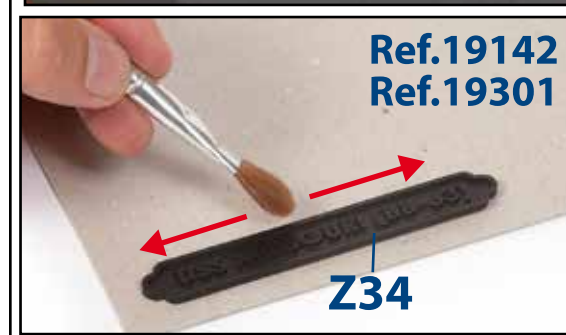
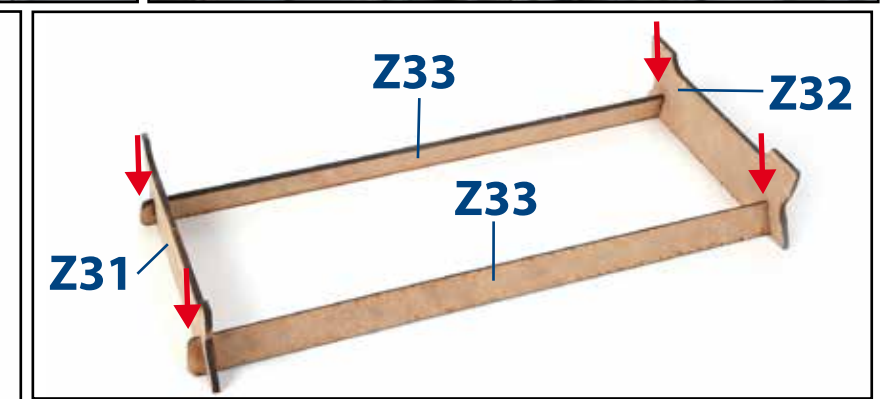
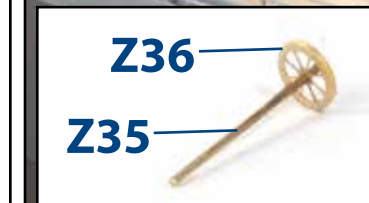
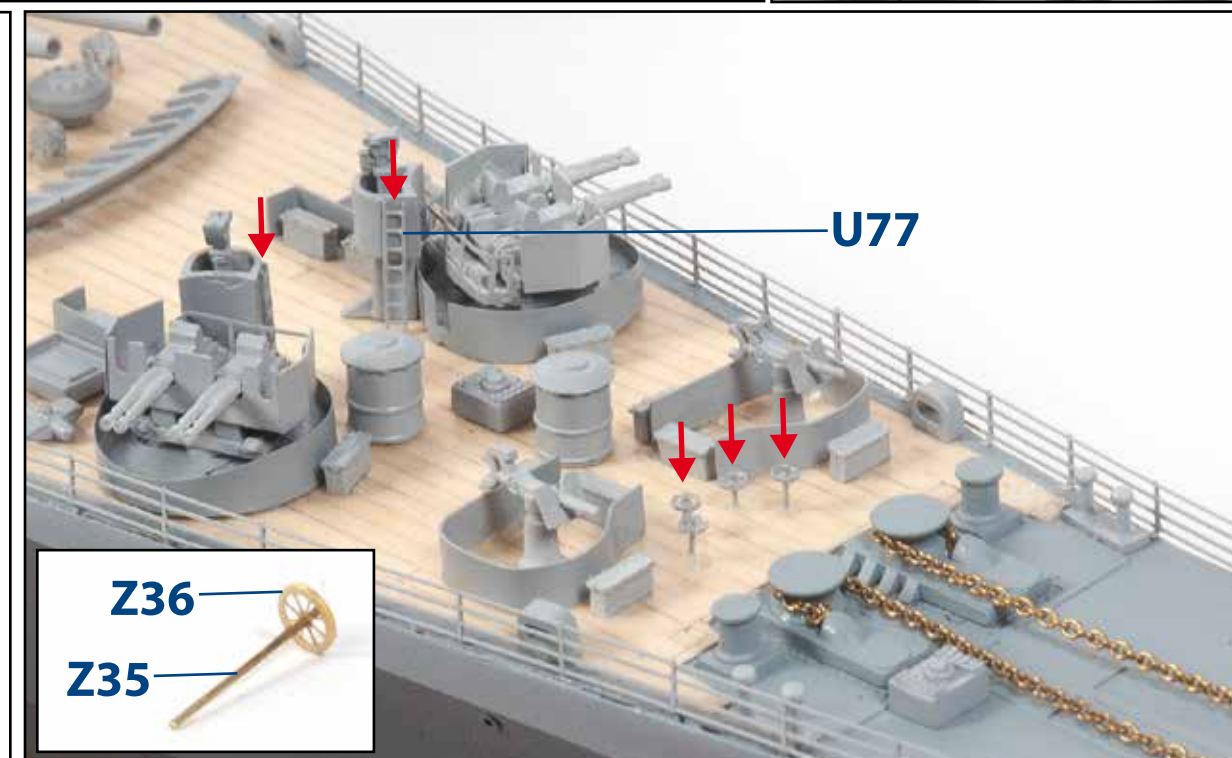
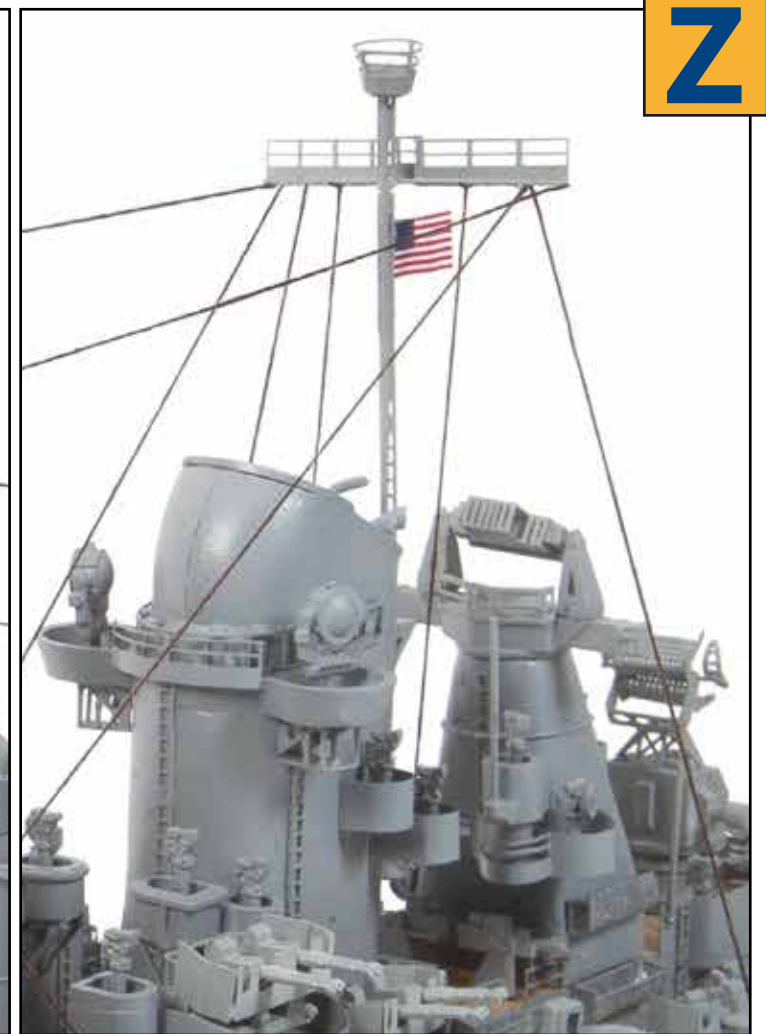
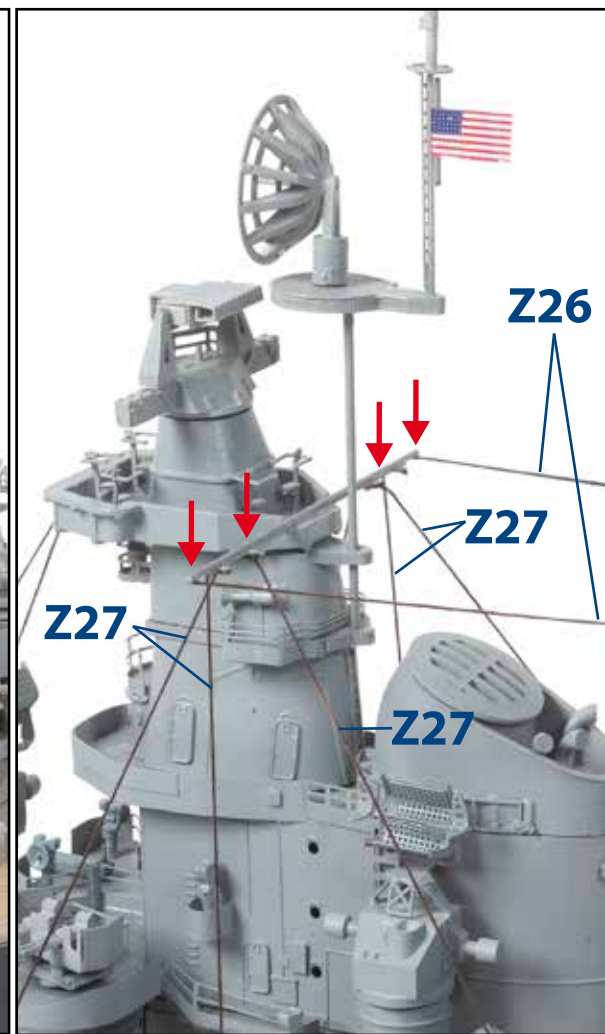
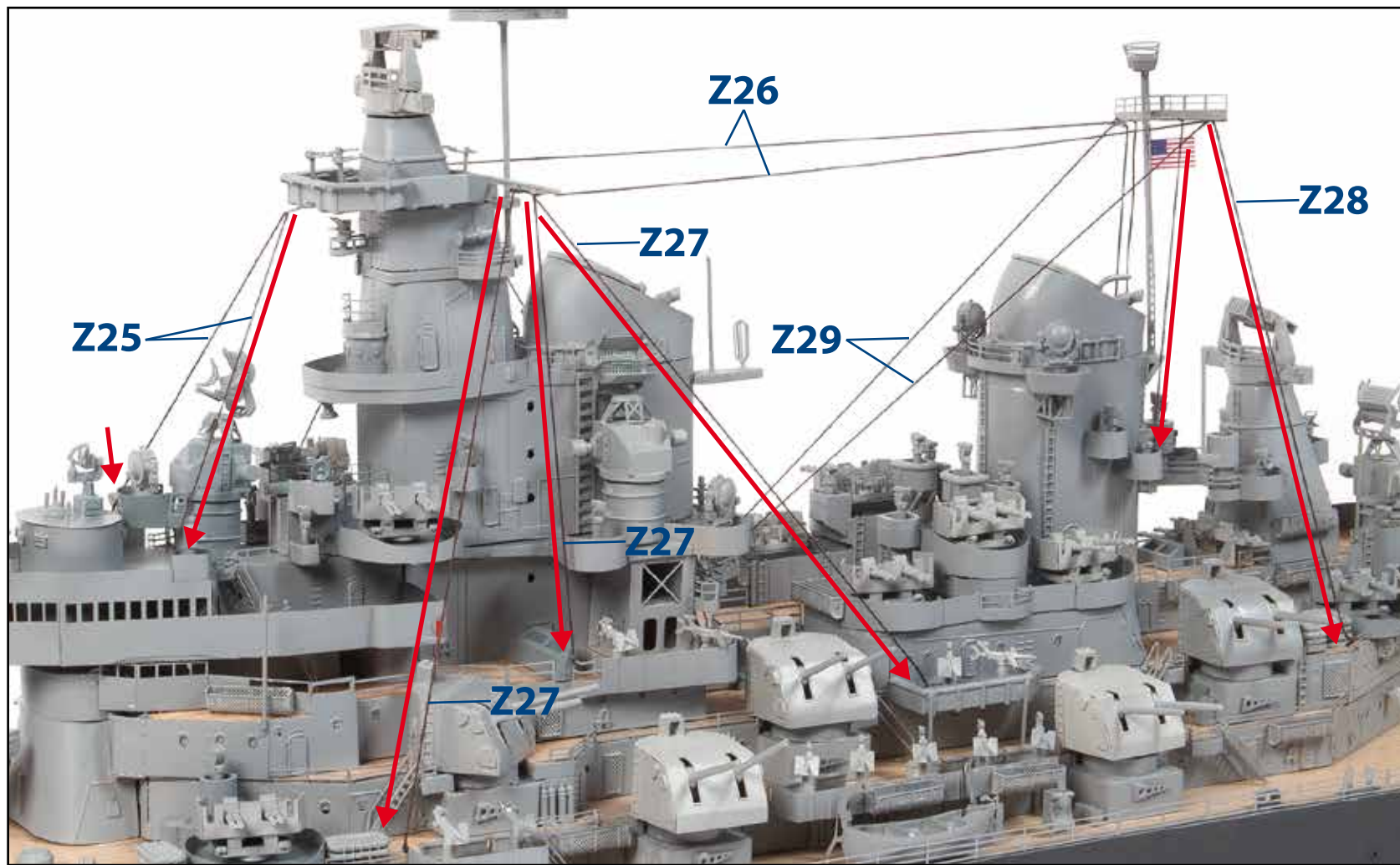

Z

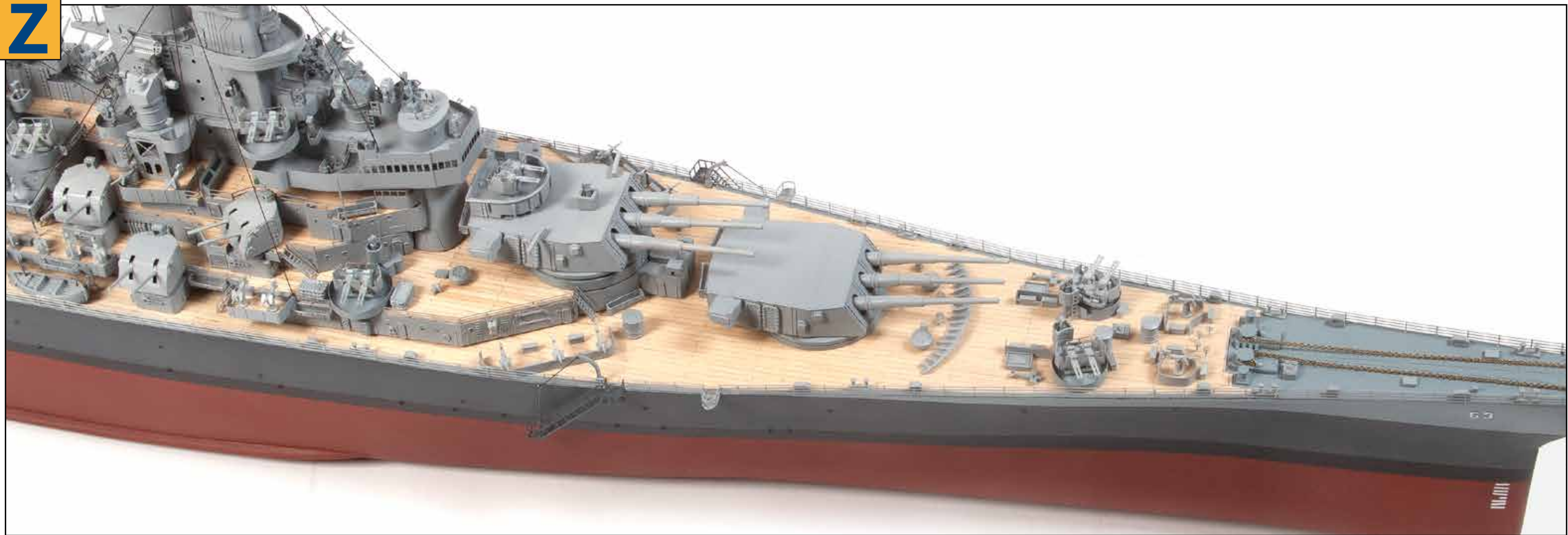



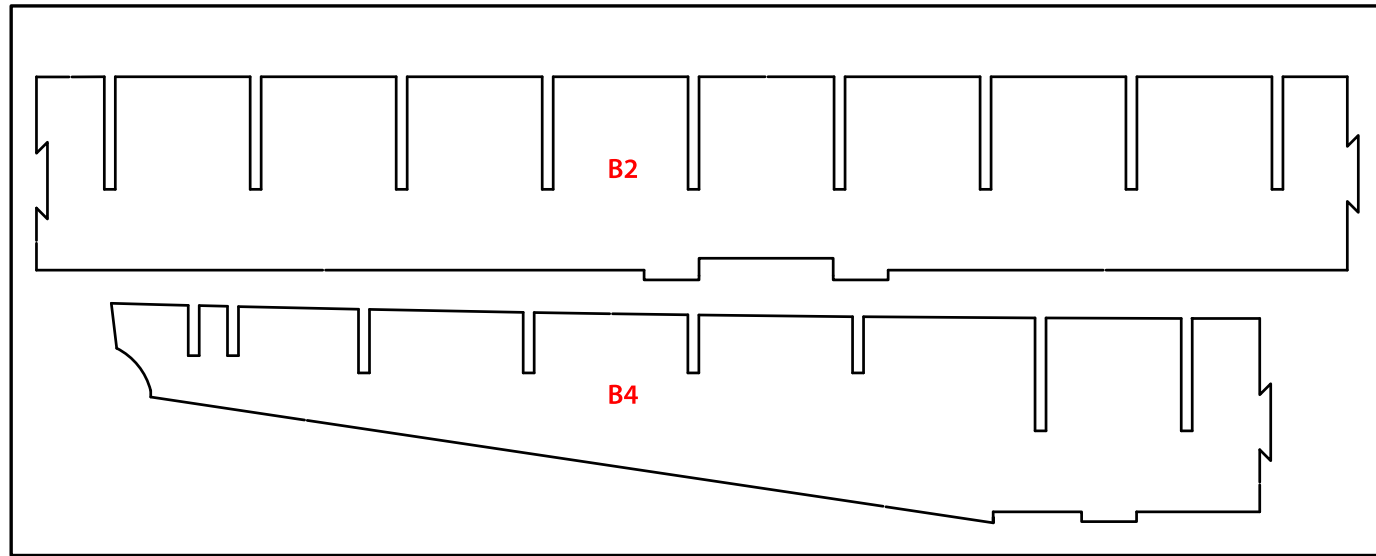

16002-1

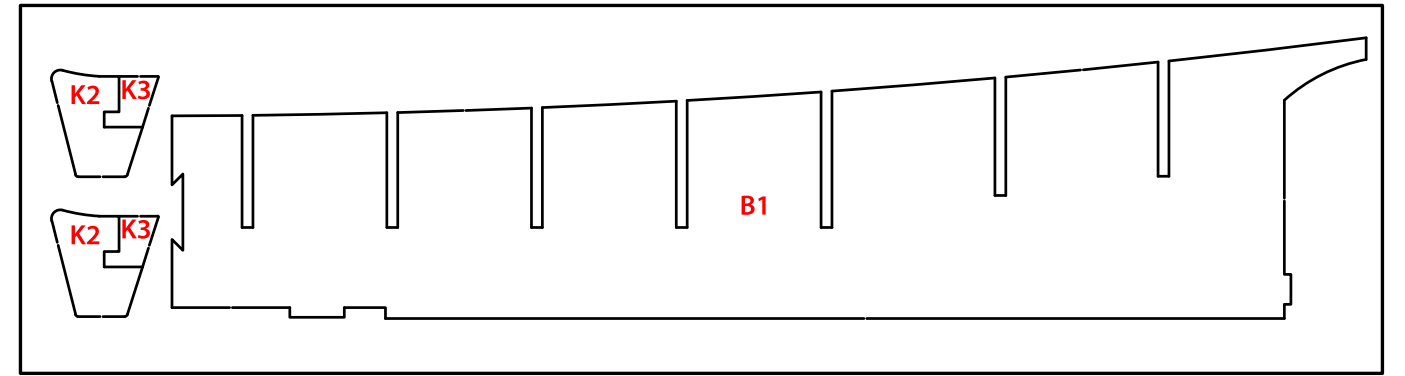

16002-2

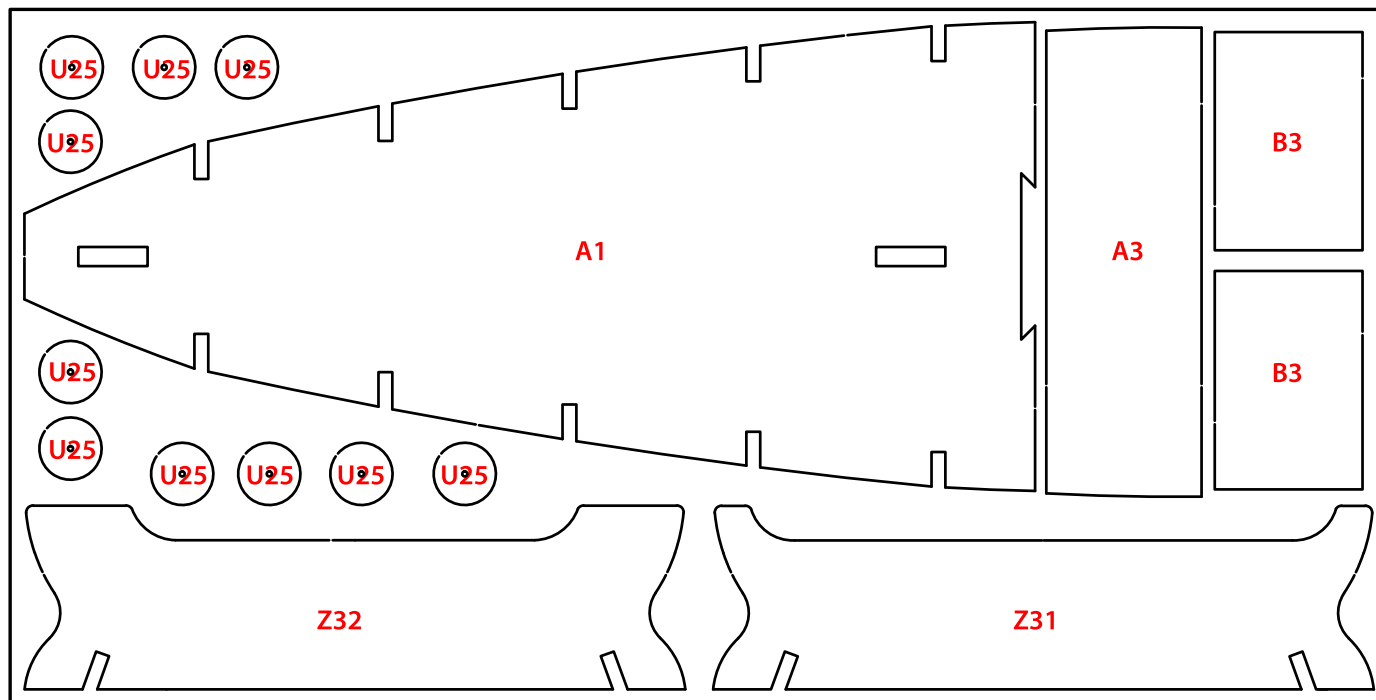

16002-3

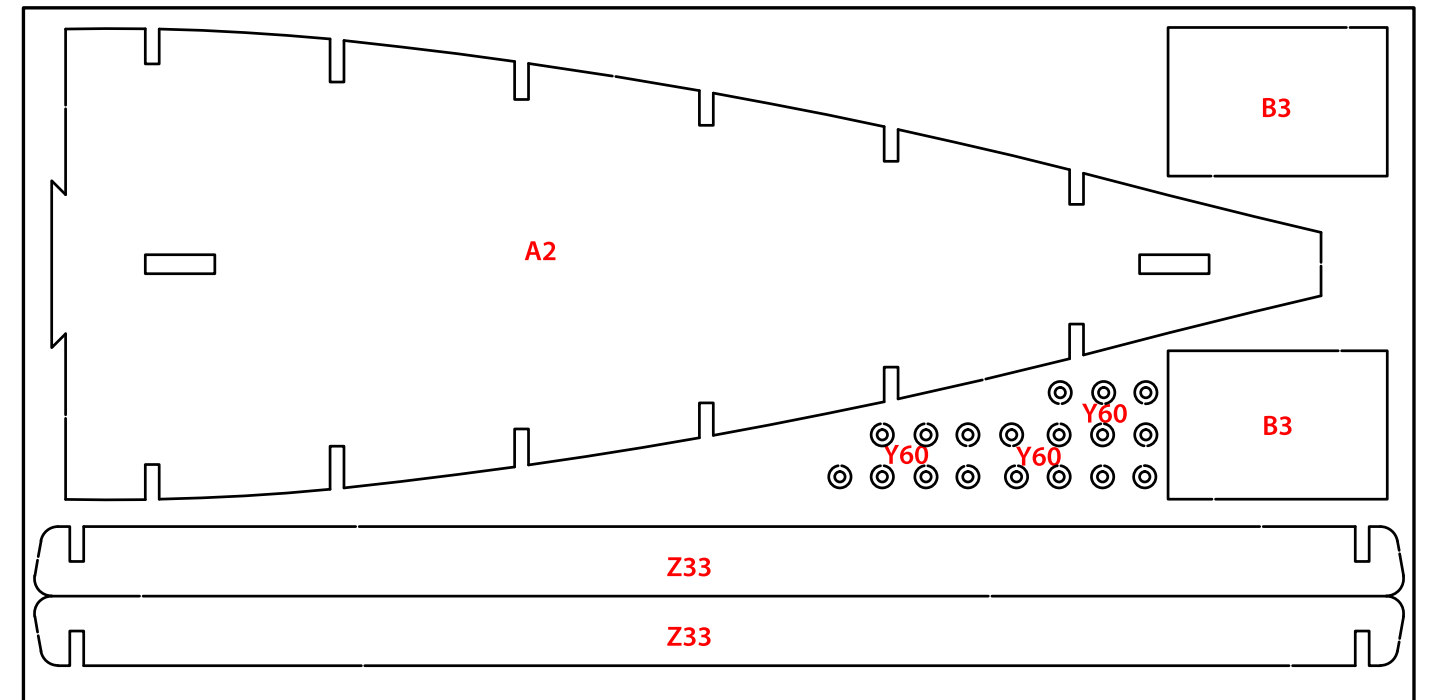

16002-4



IP

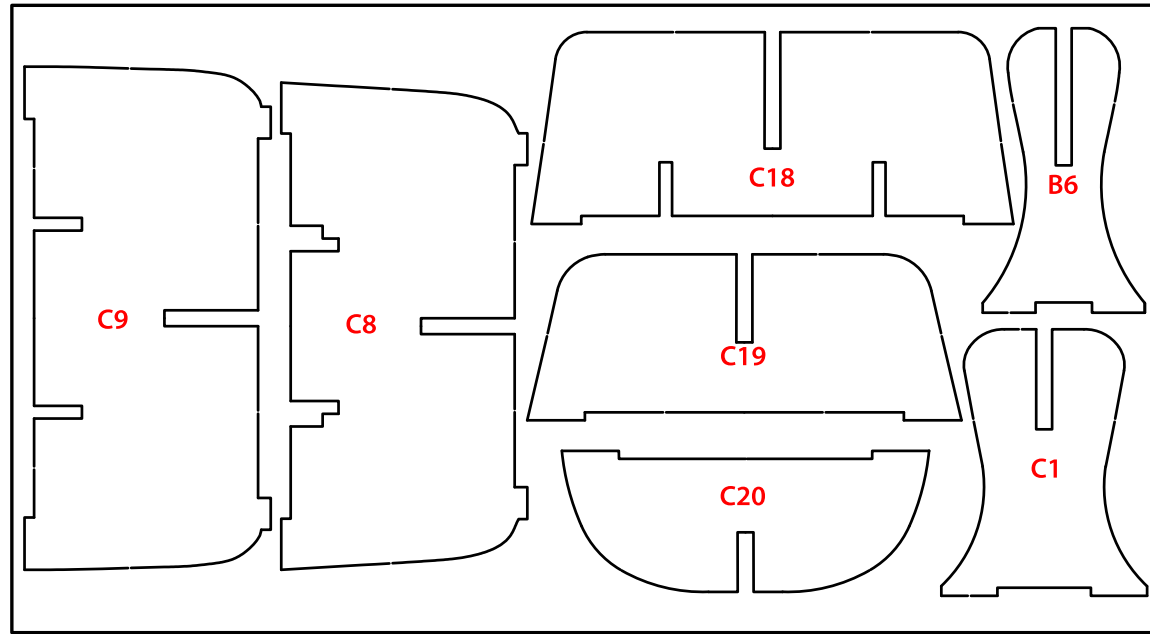

16002-6

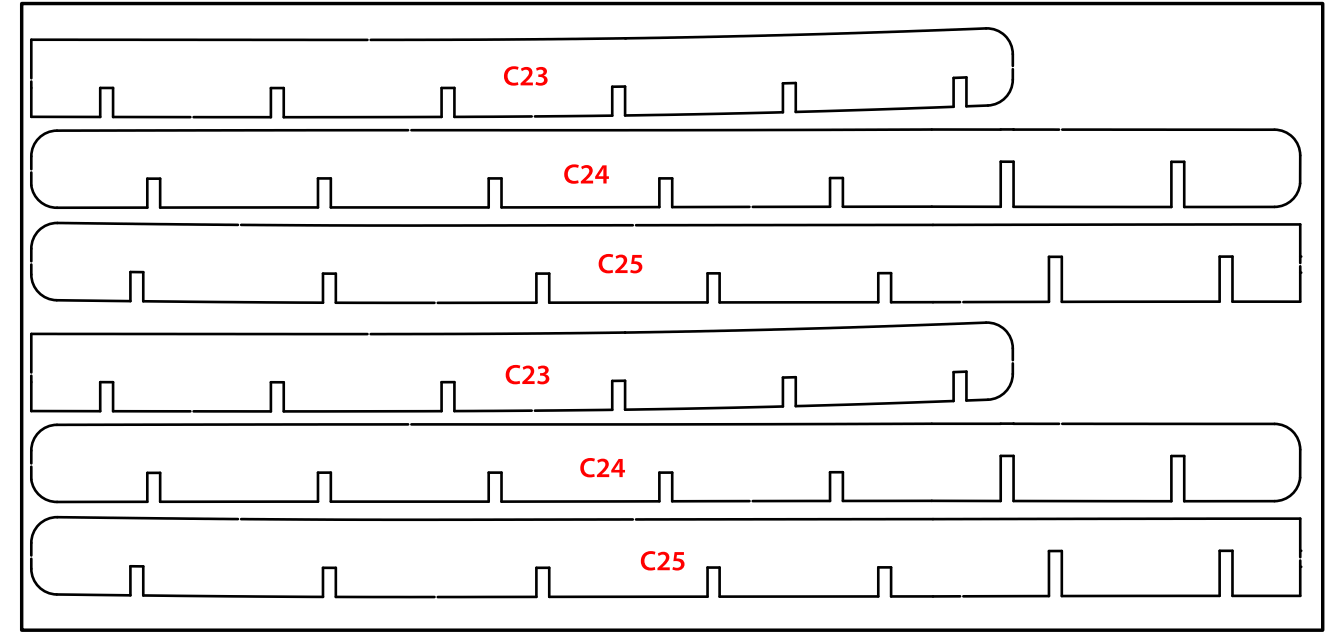

16002-9

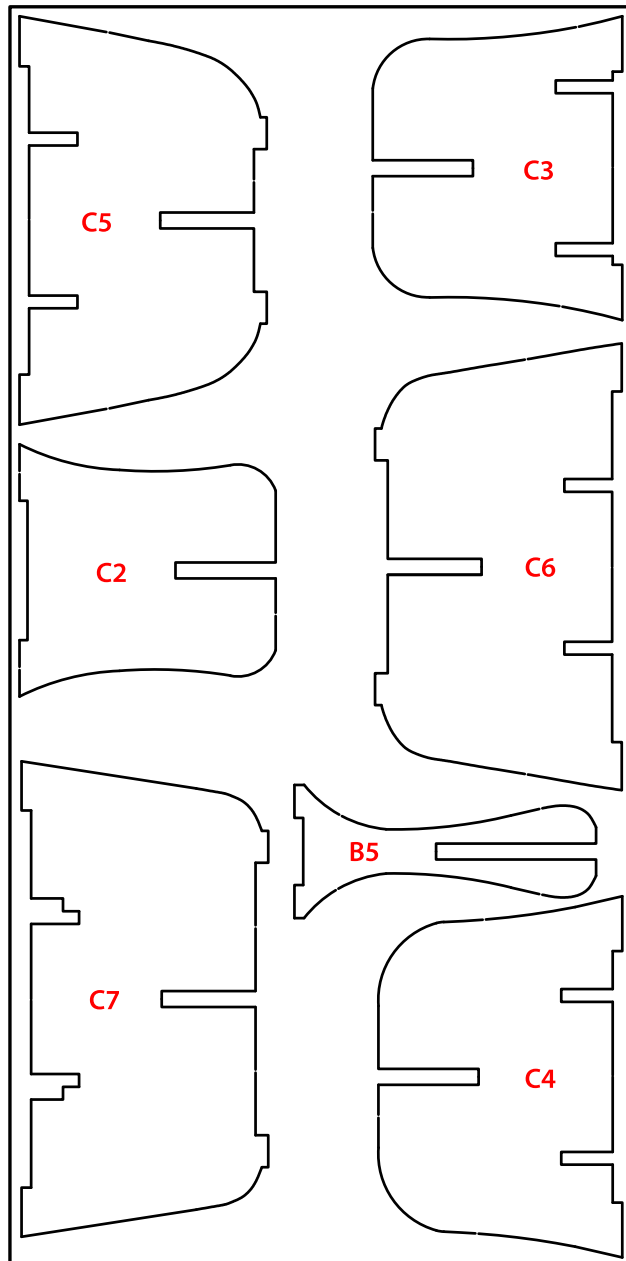

16002-5

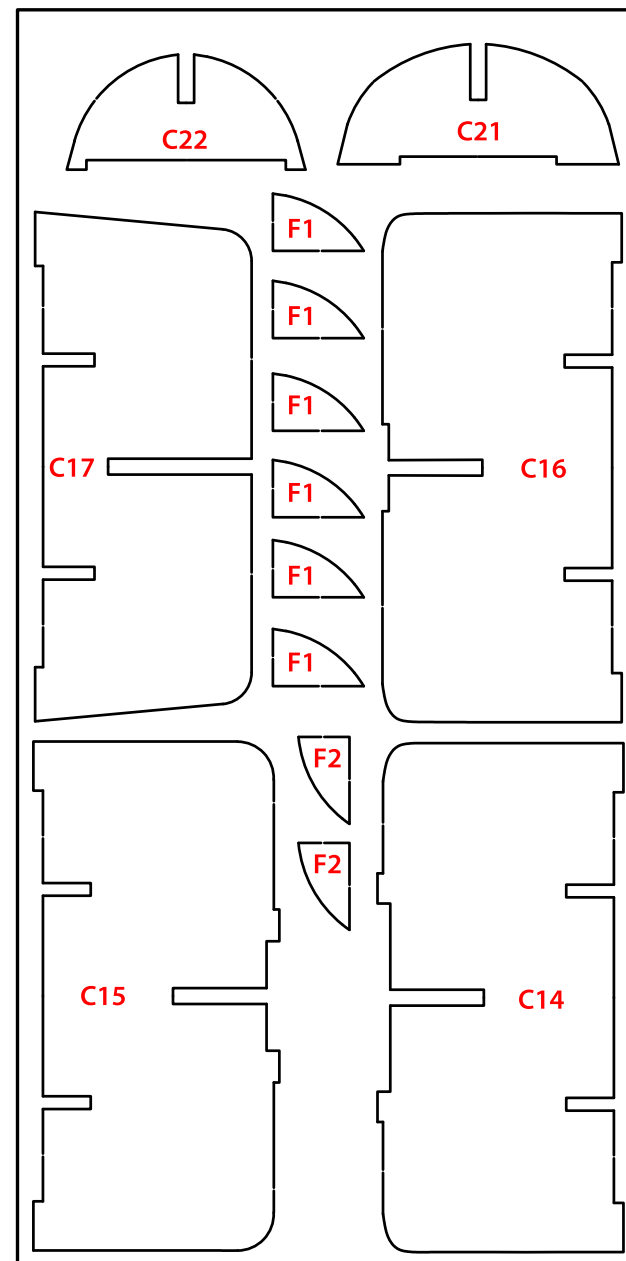

16002-8

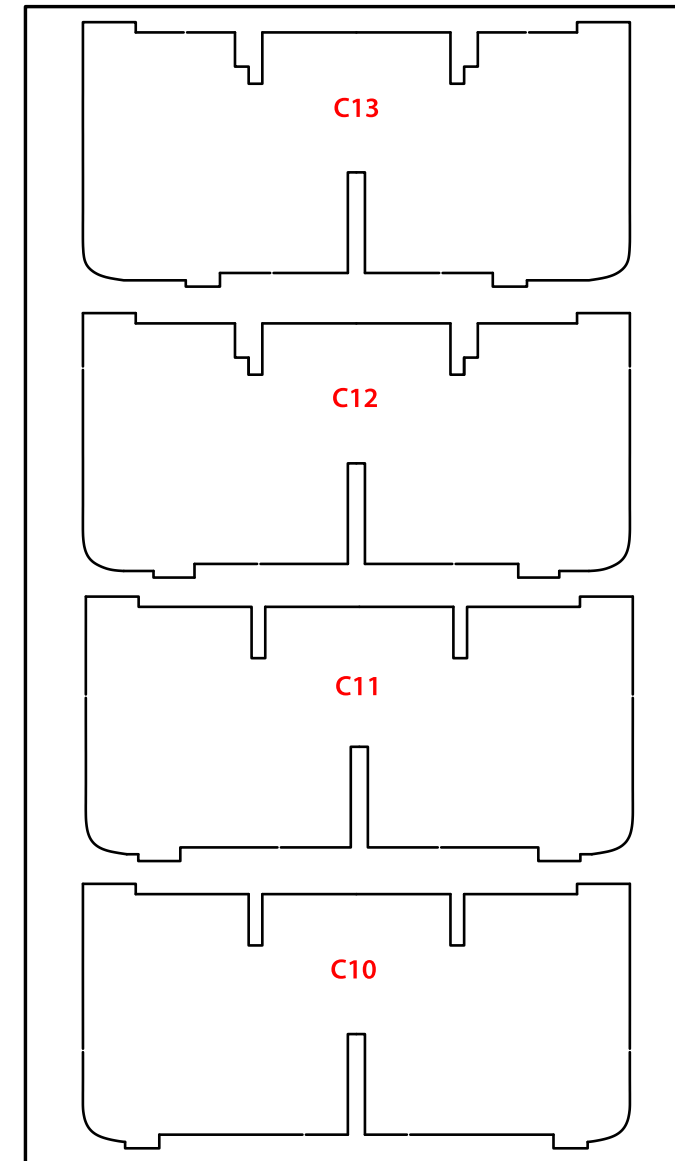

16002-7

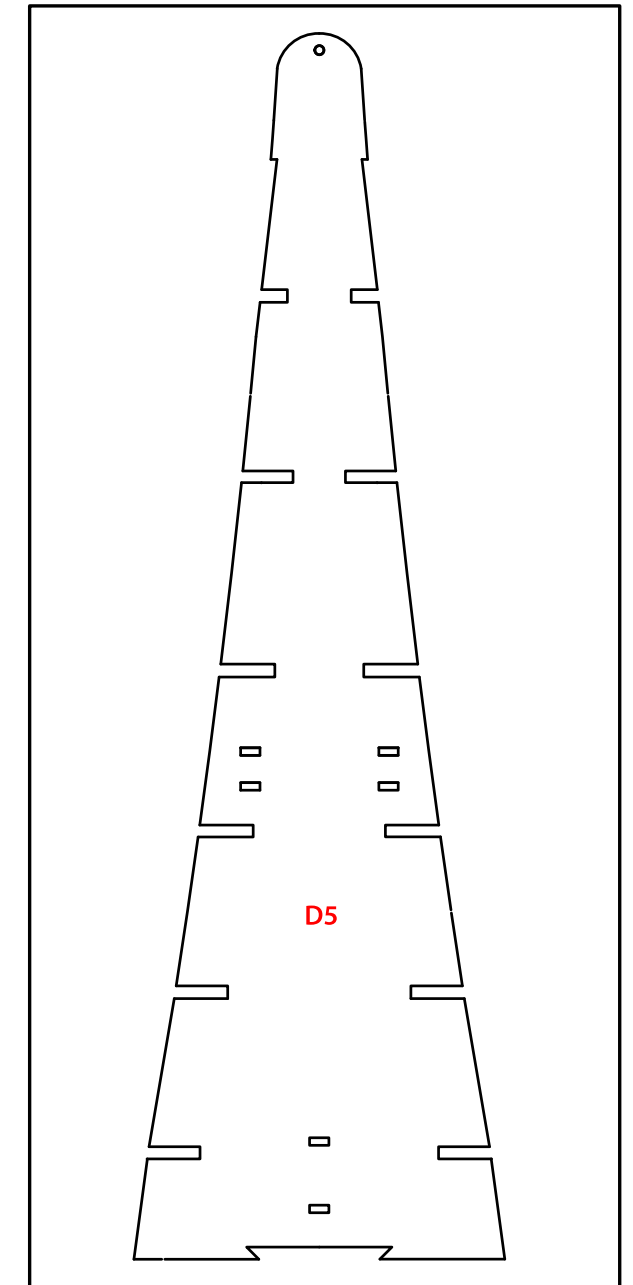

16002-13

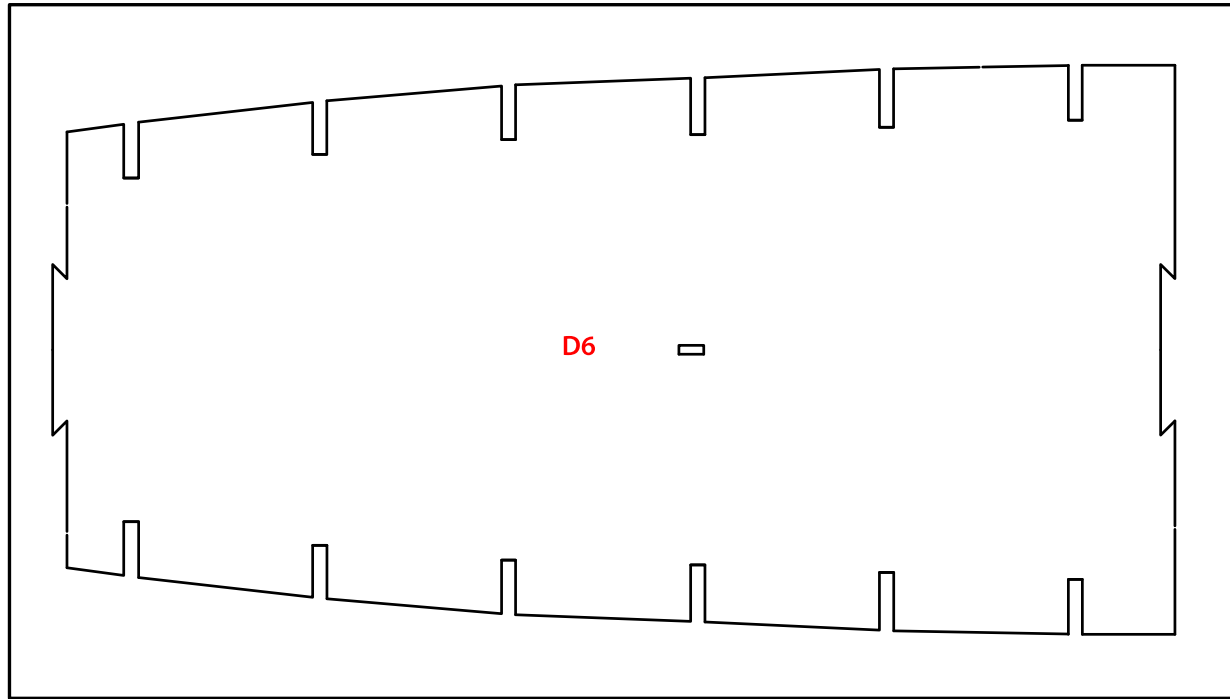

16002-12

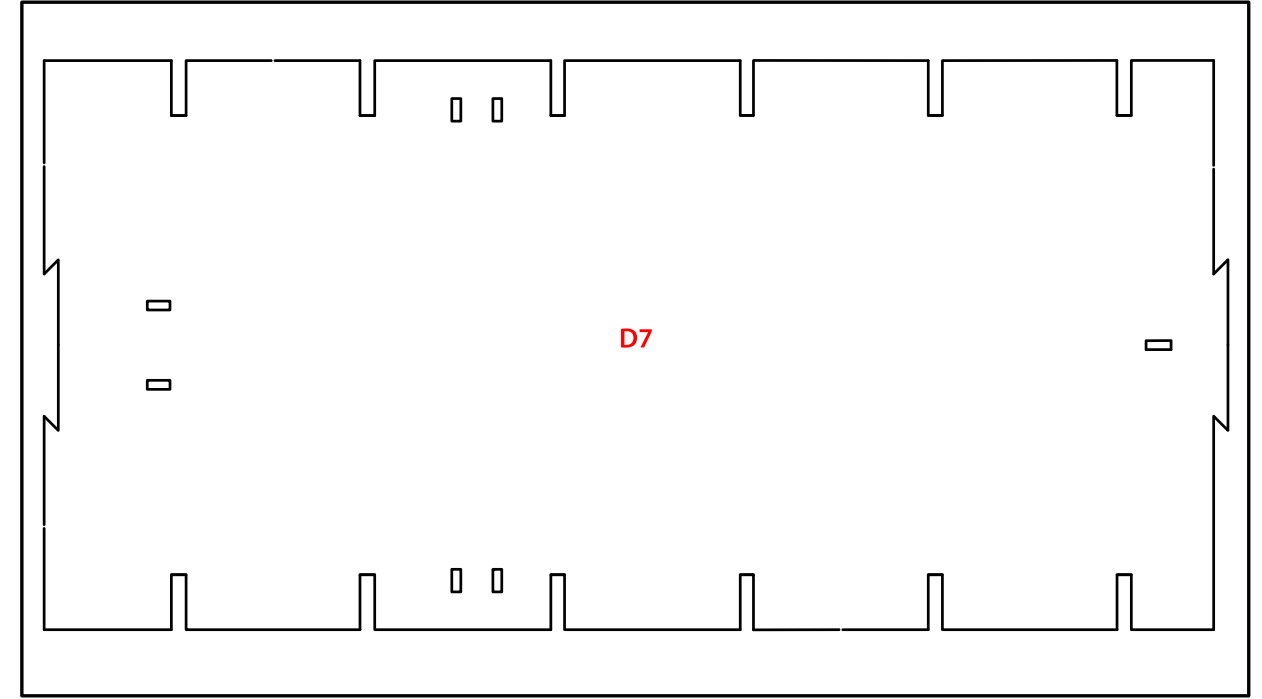

16002-11

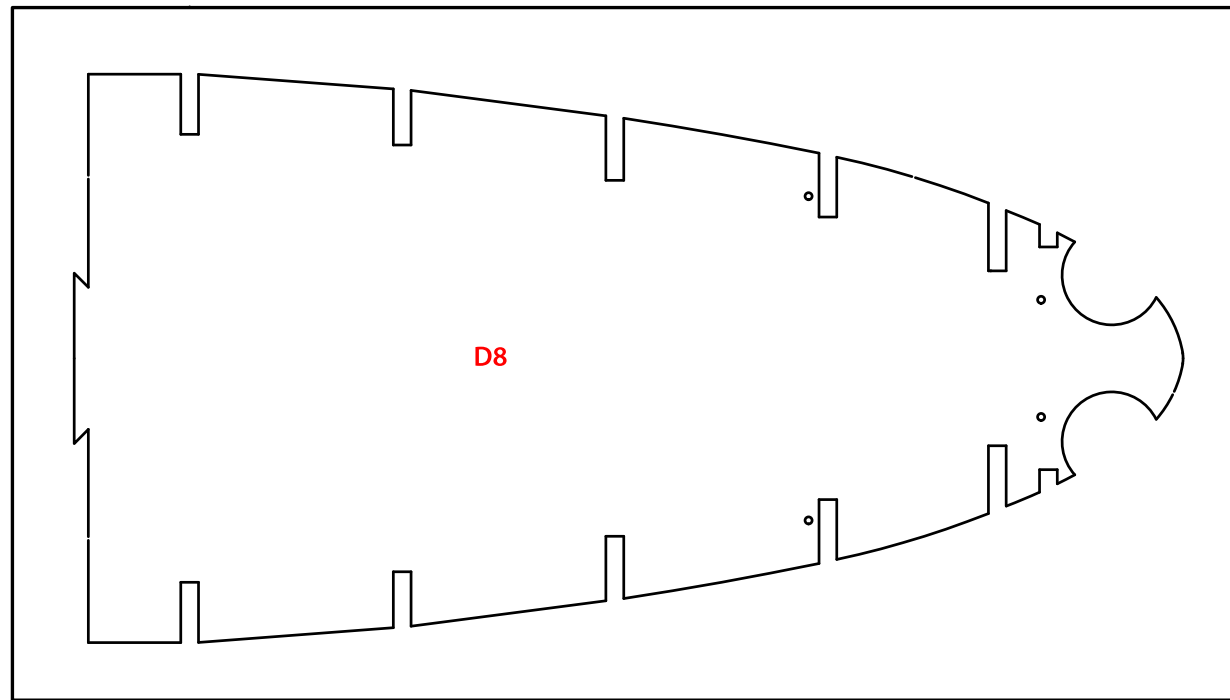

16002-10

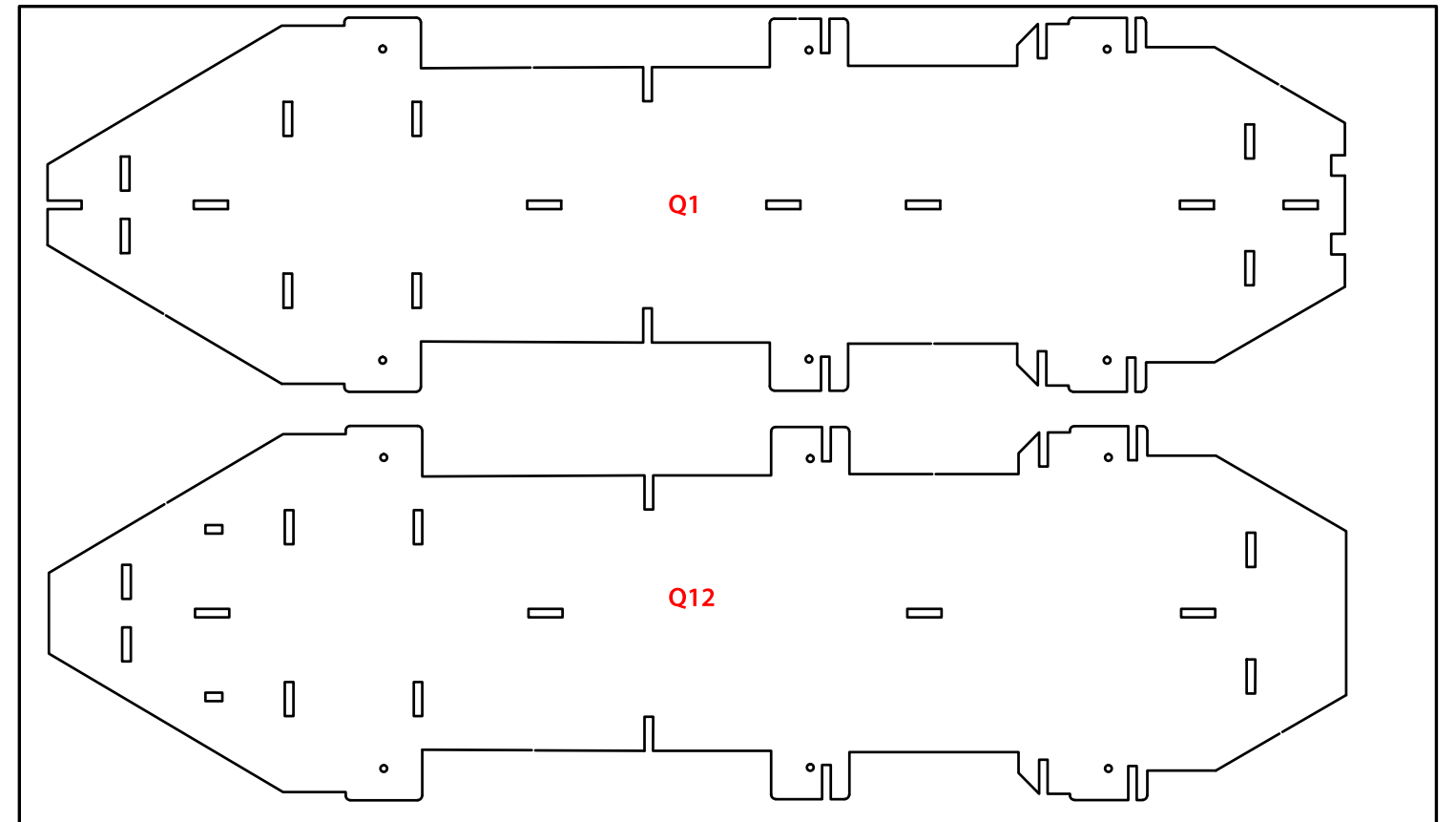

16002-16

IP

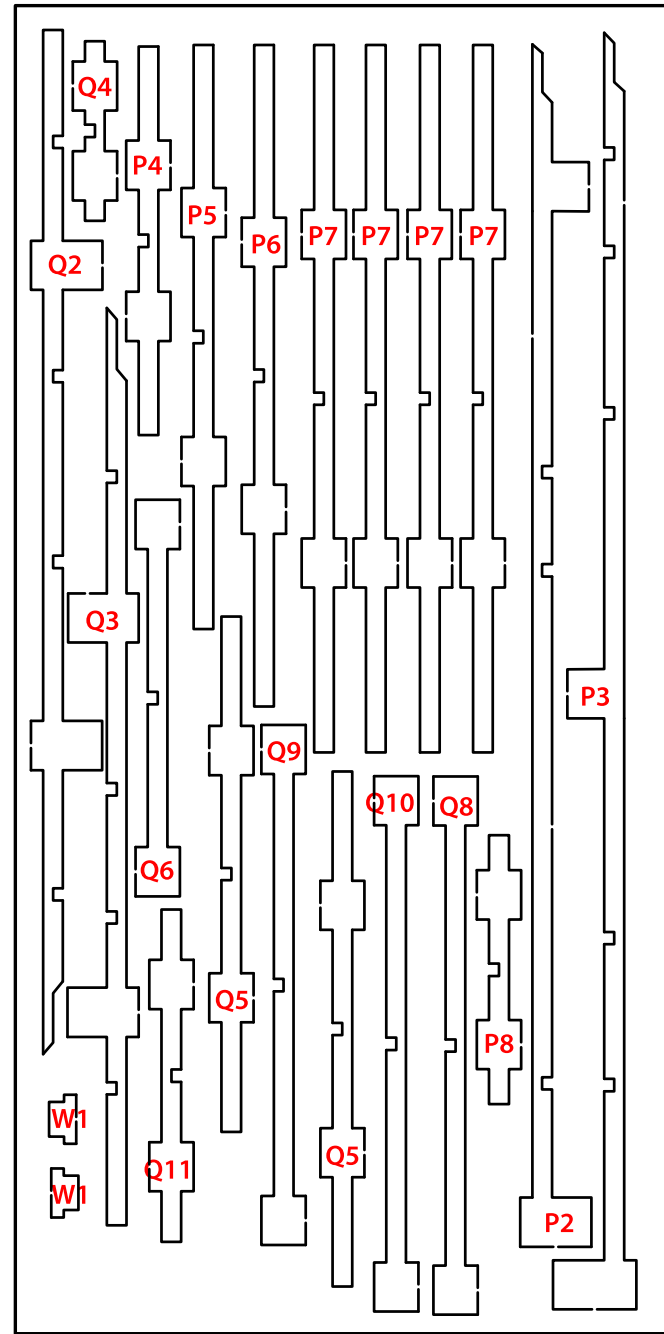

16002-15

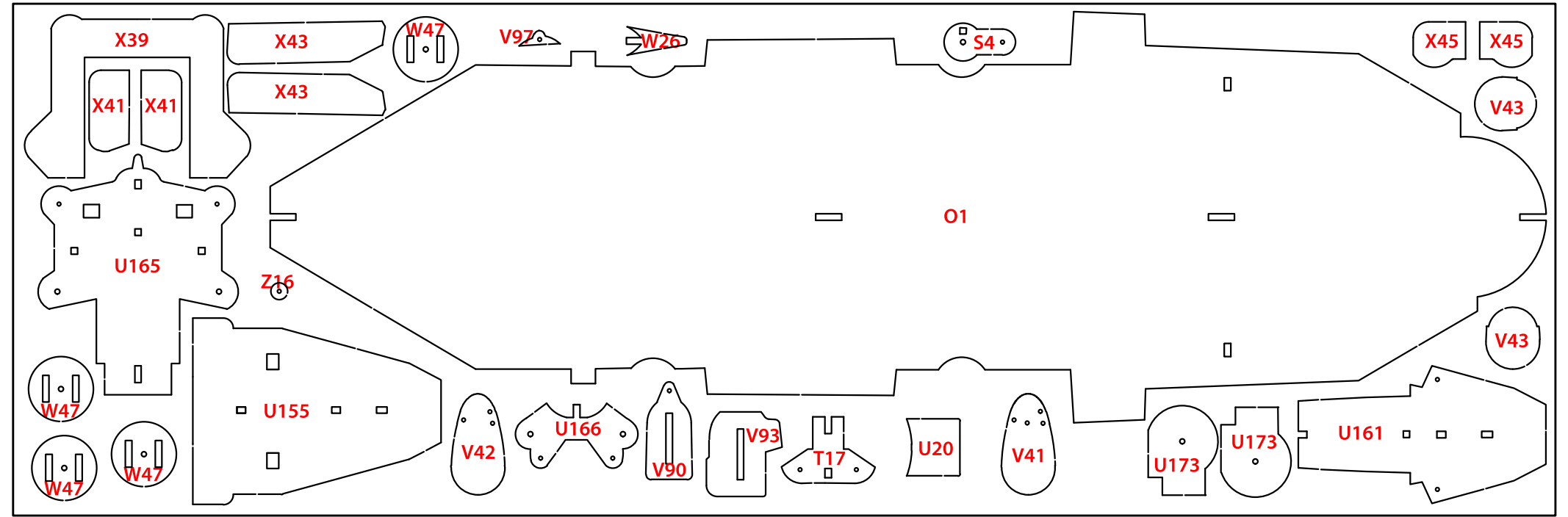

16002-17

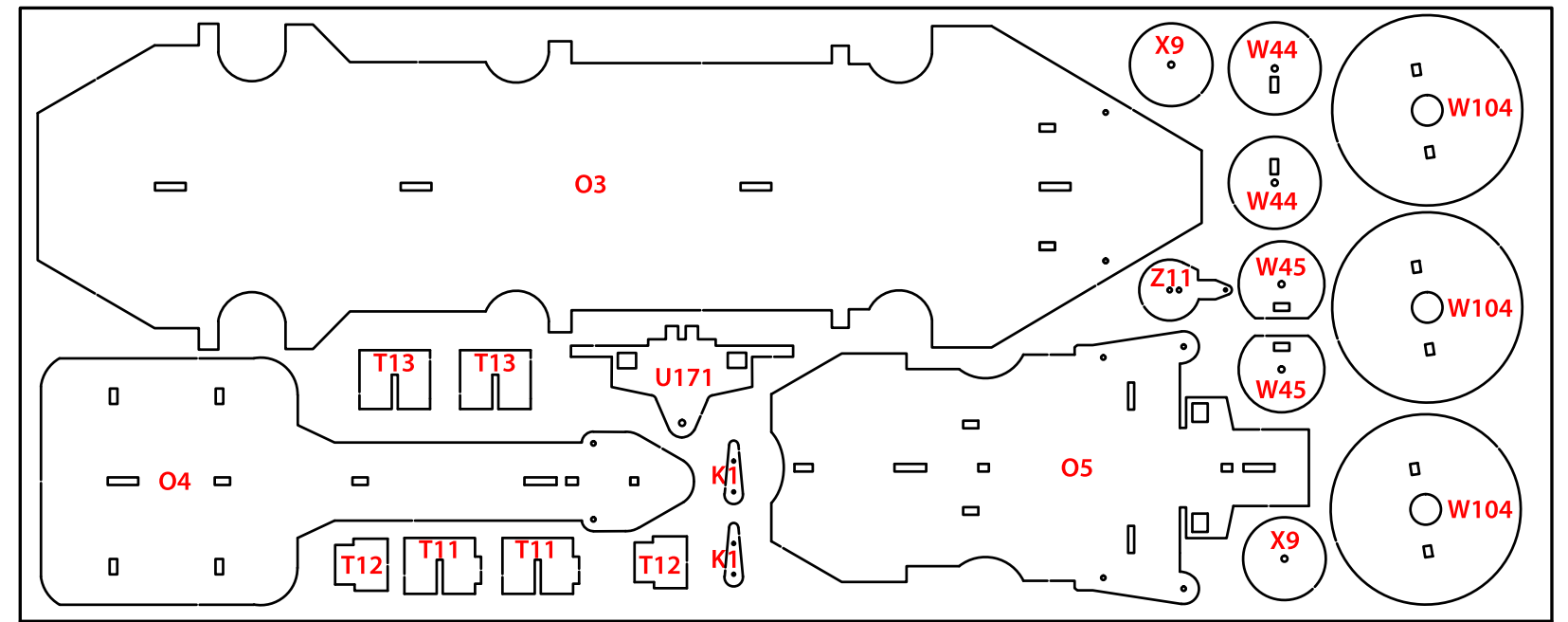

16002-20

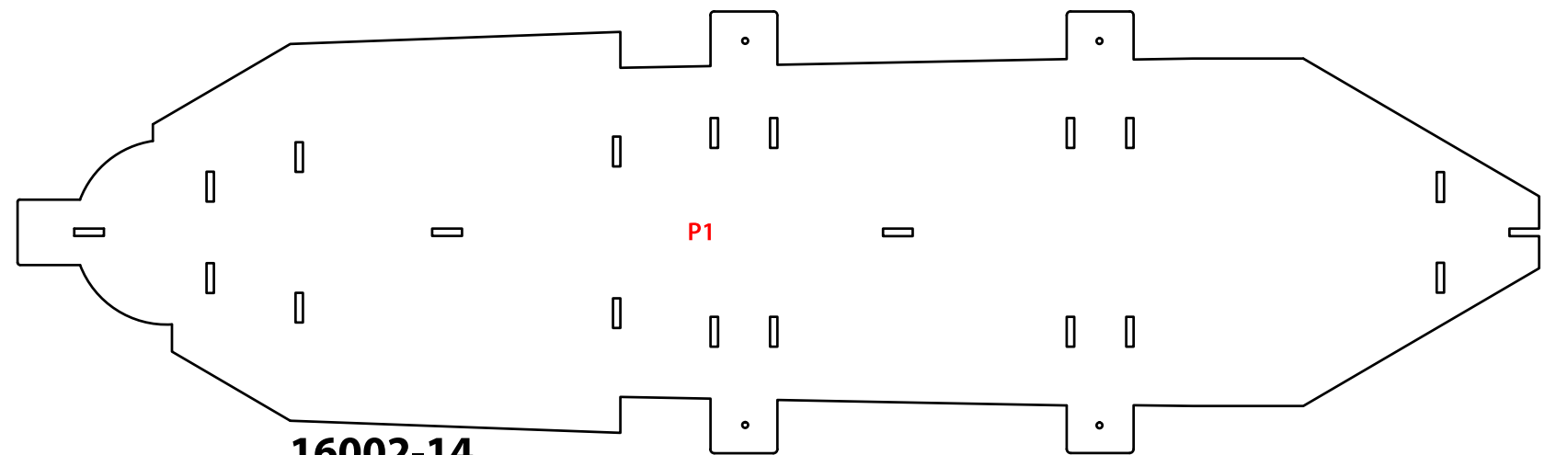

16002-14

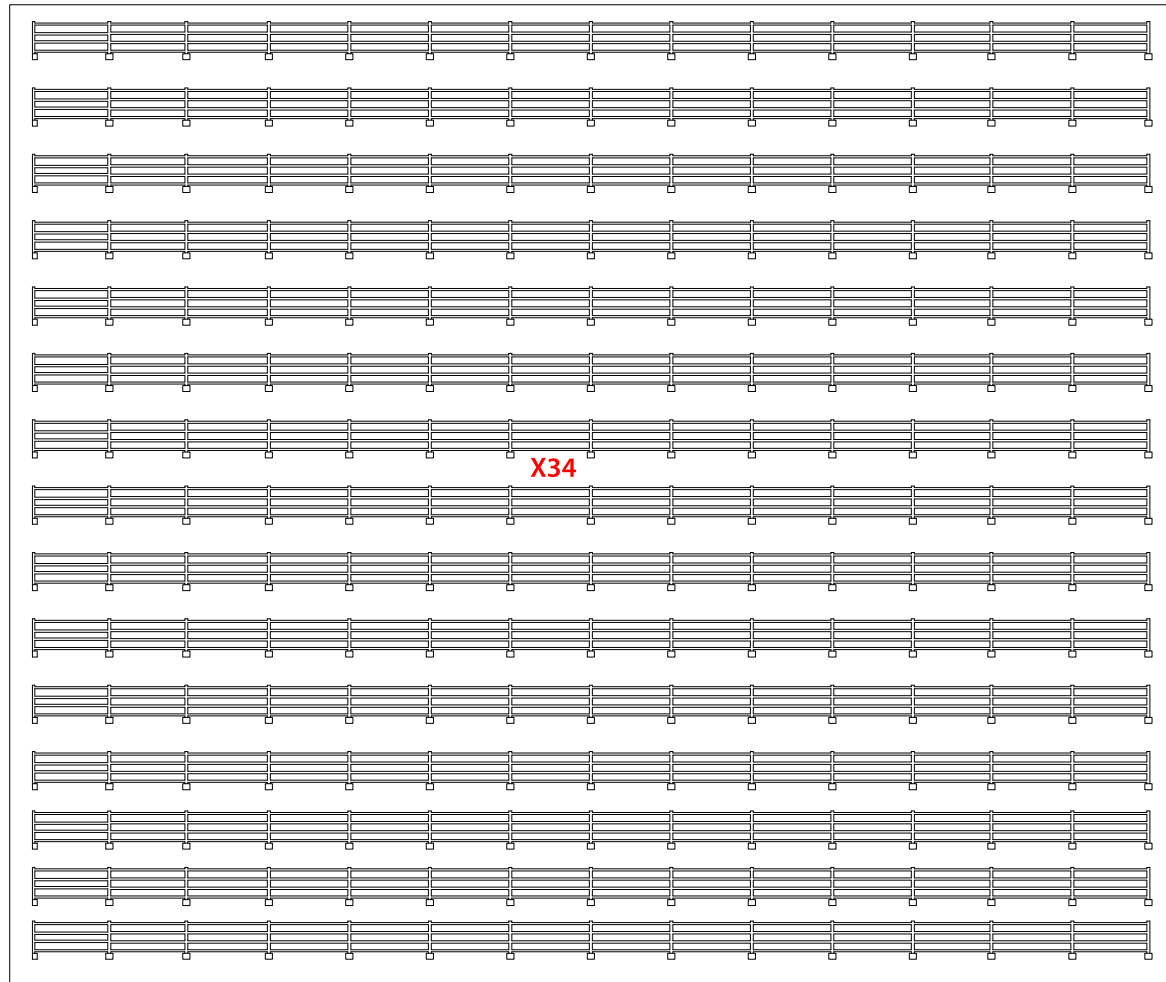

16002-34

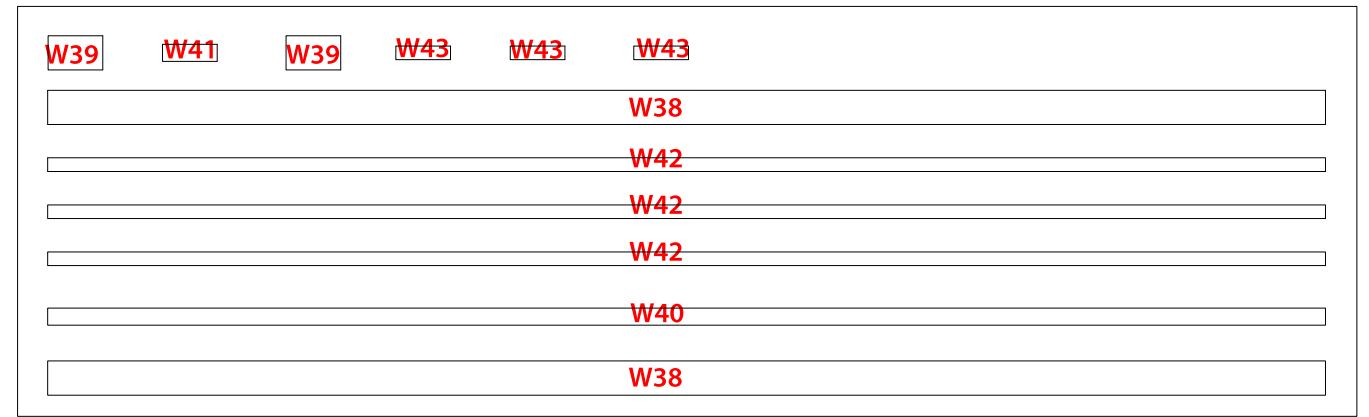

16002-35

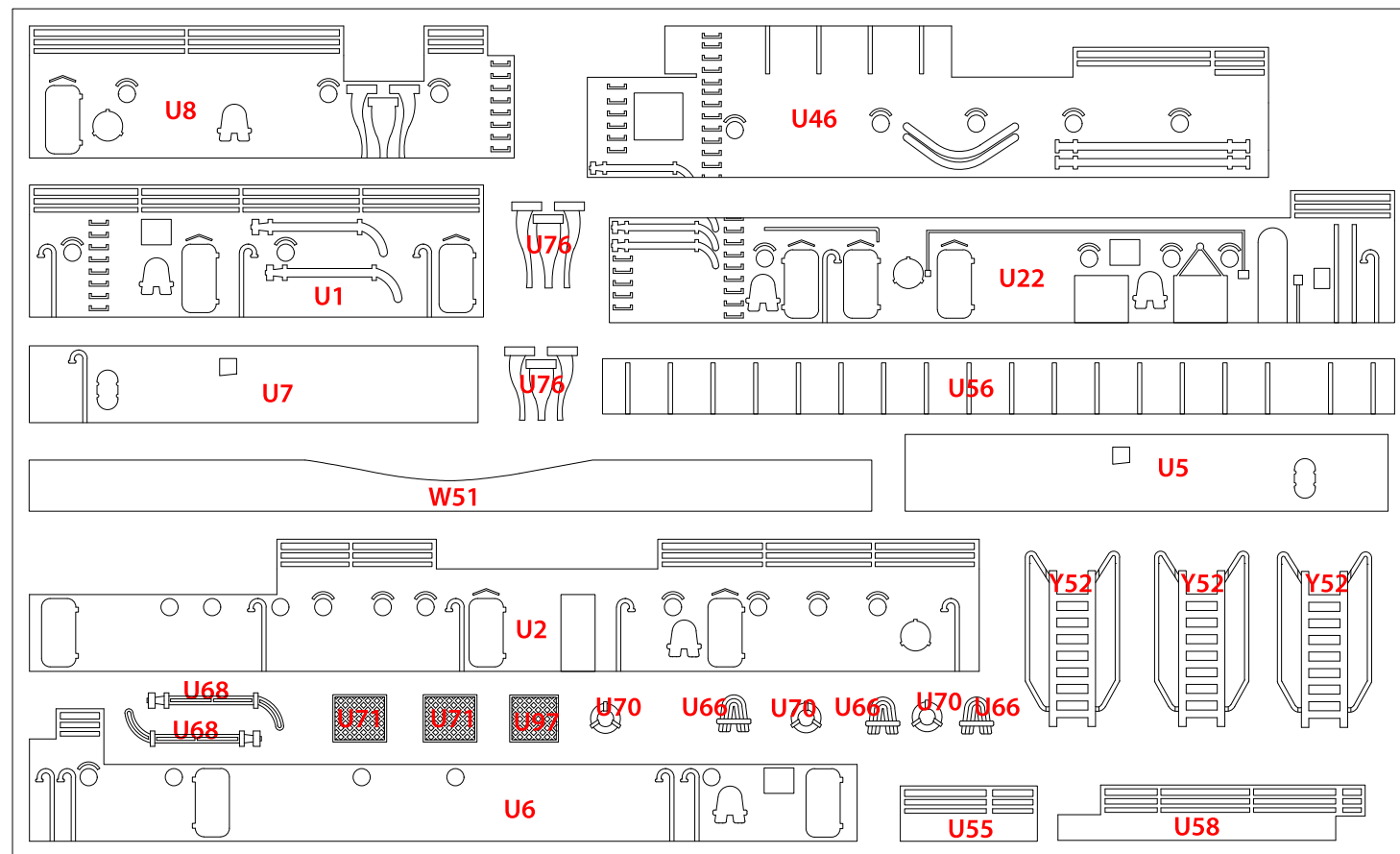

16002-23

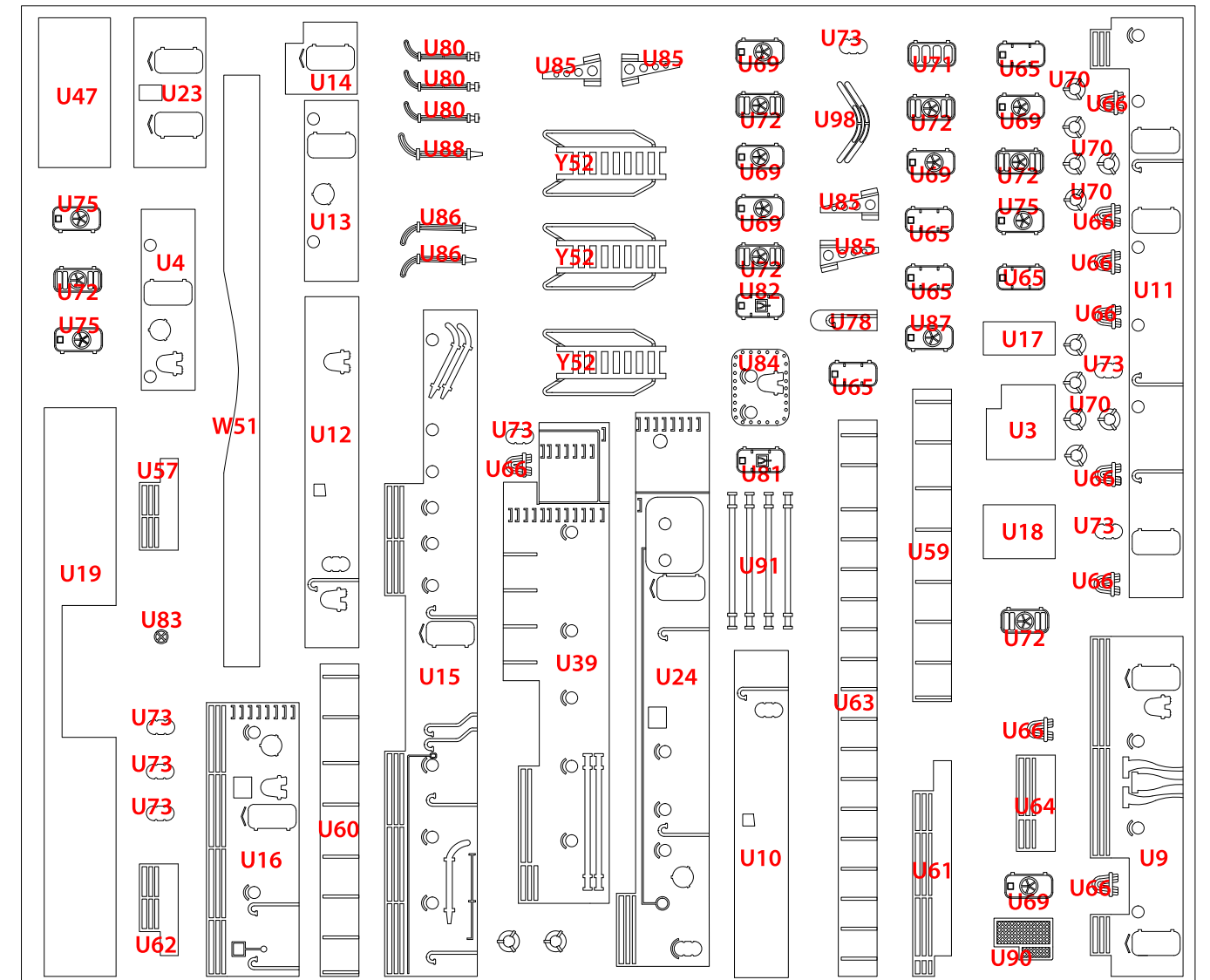

16002-22

IP

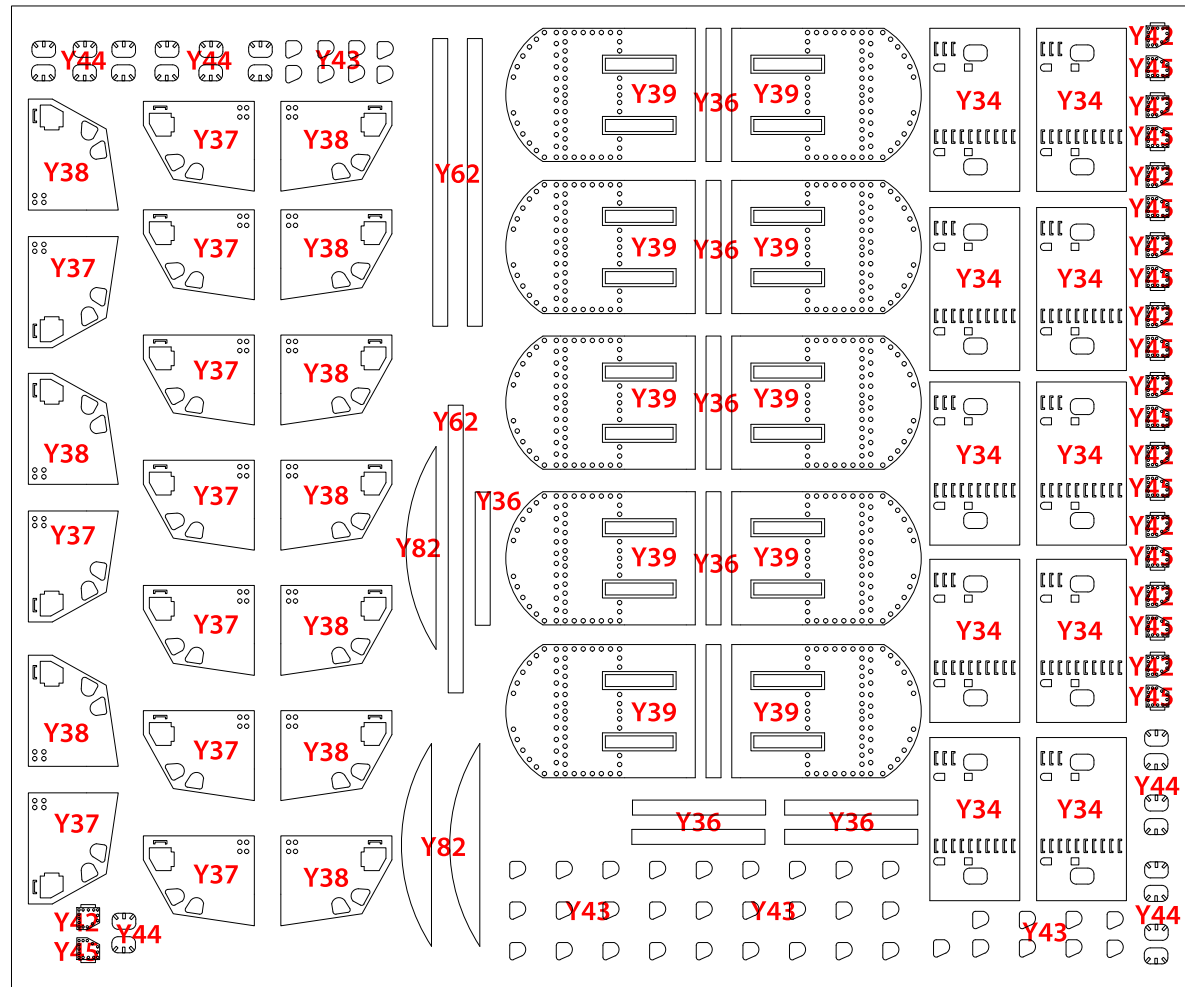

16002-30

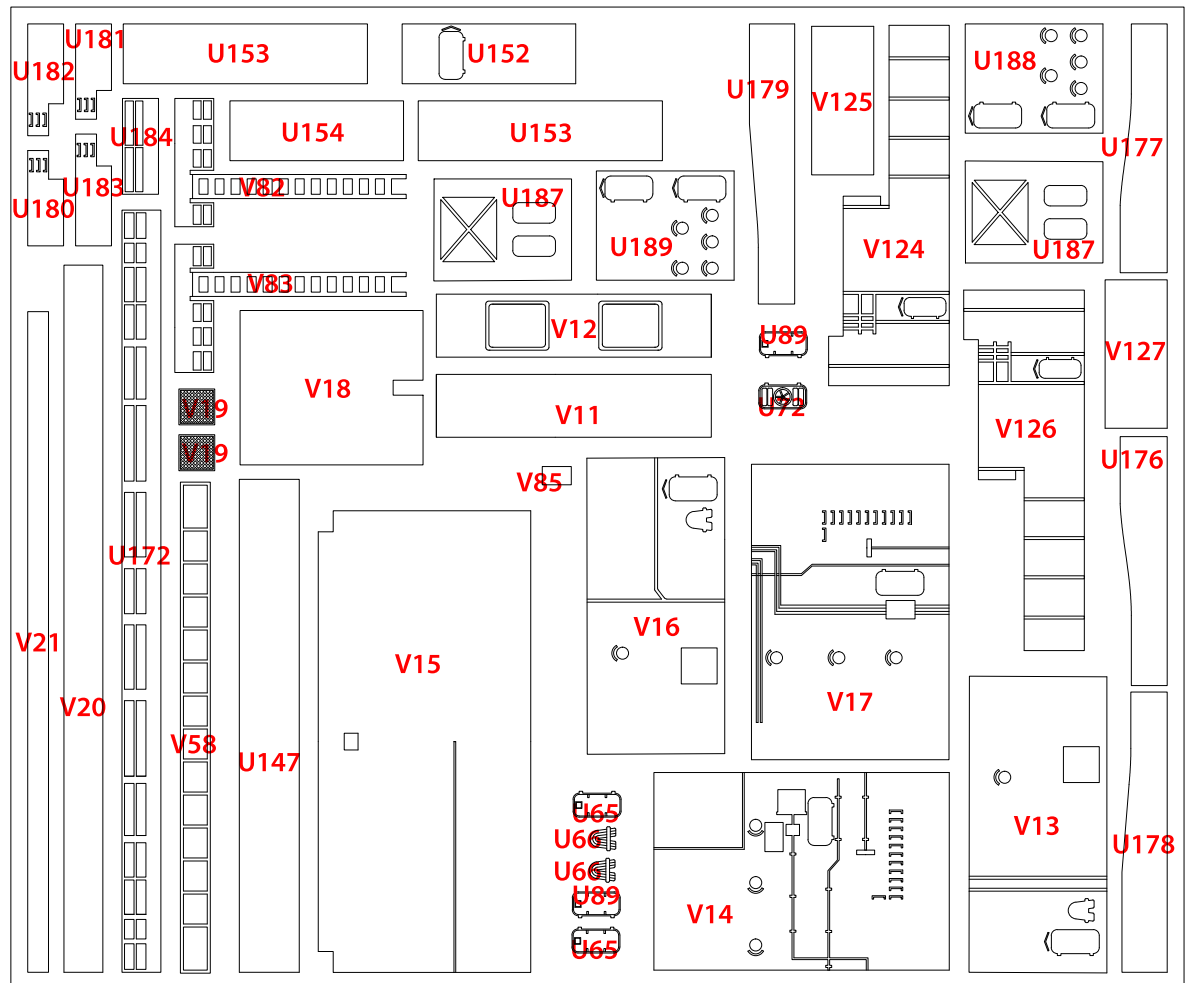

16002-26

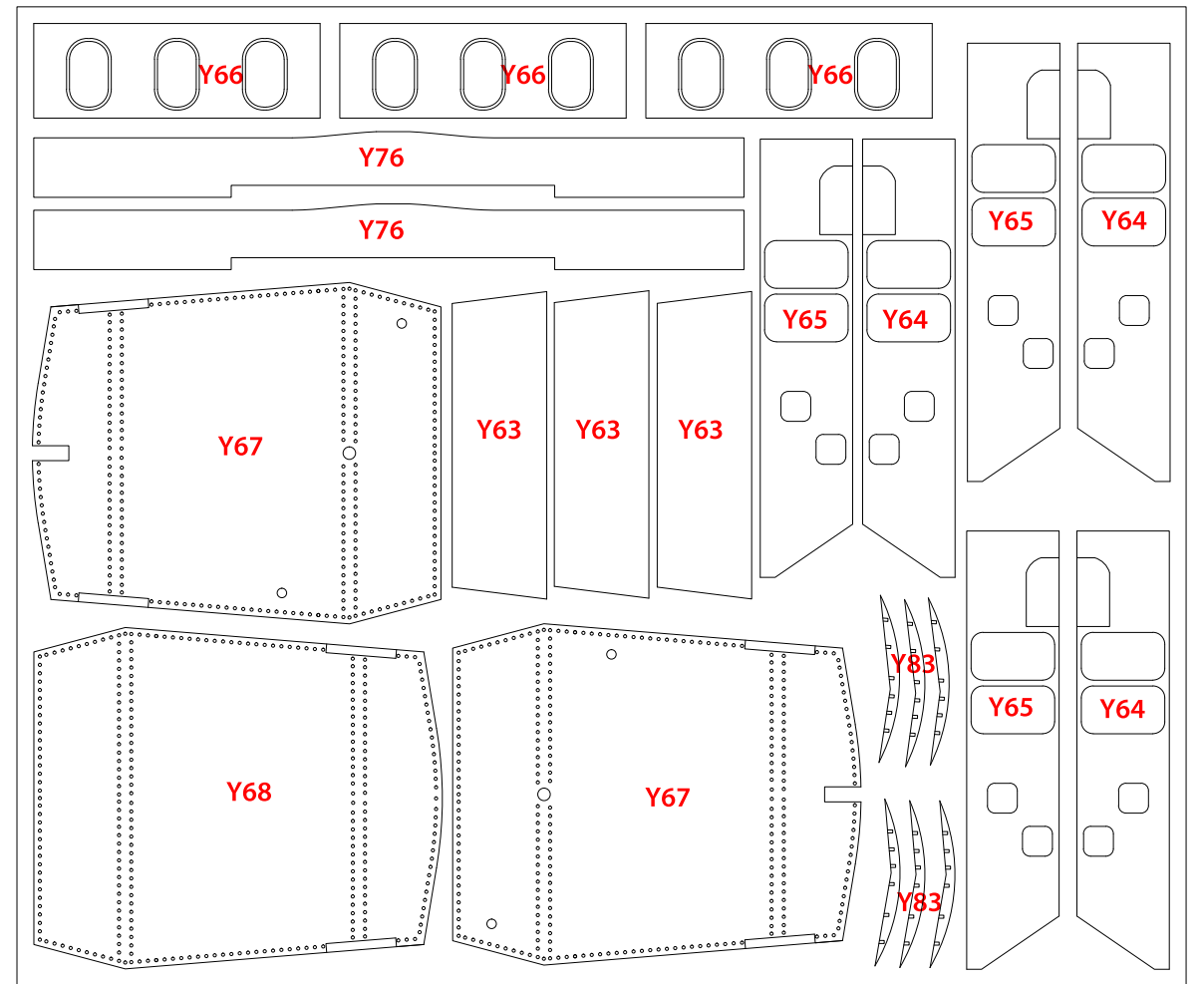

16002-29

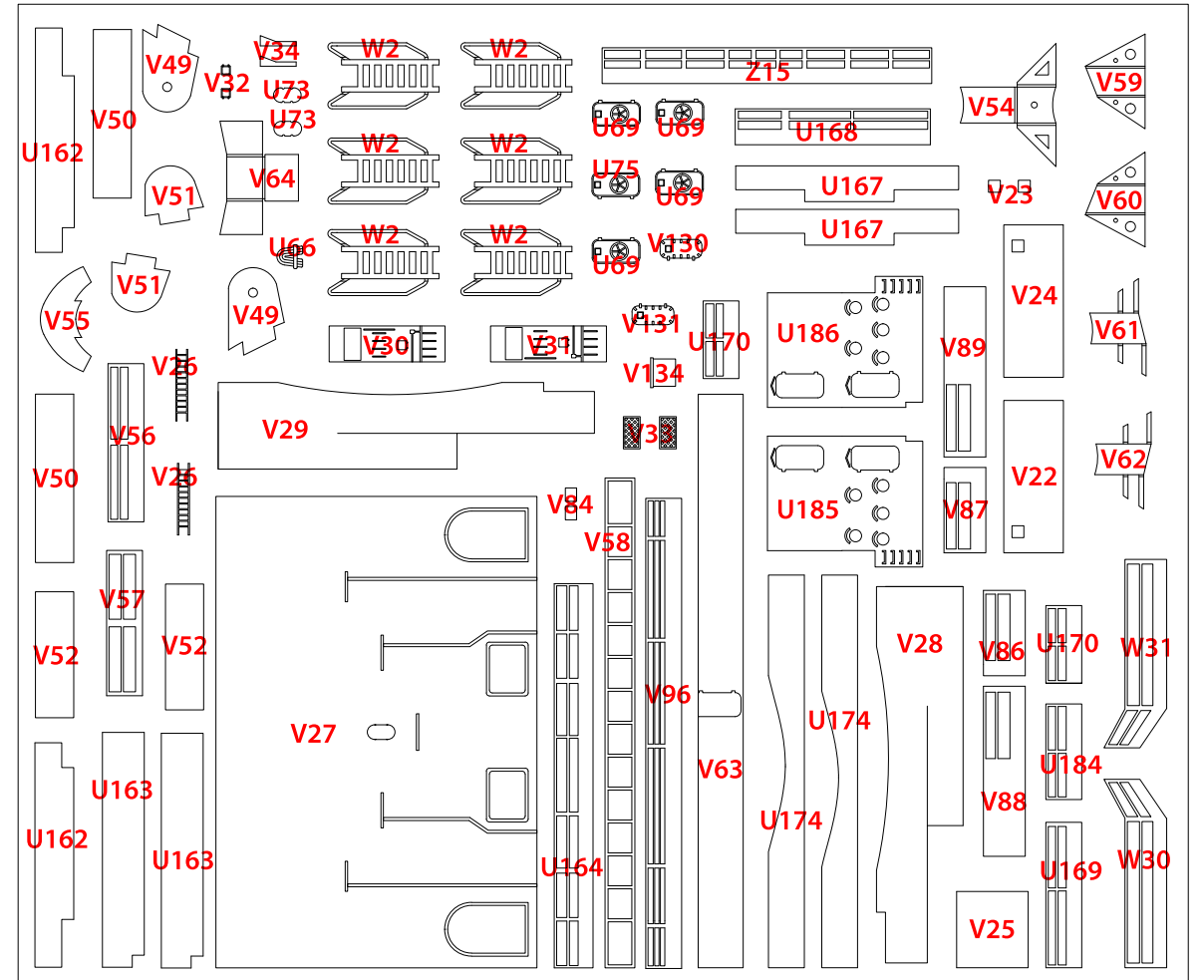

16002-28

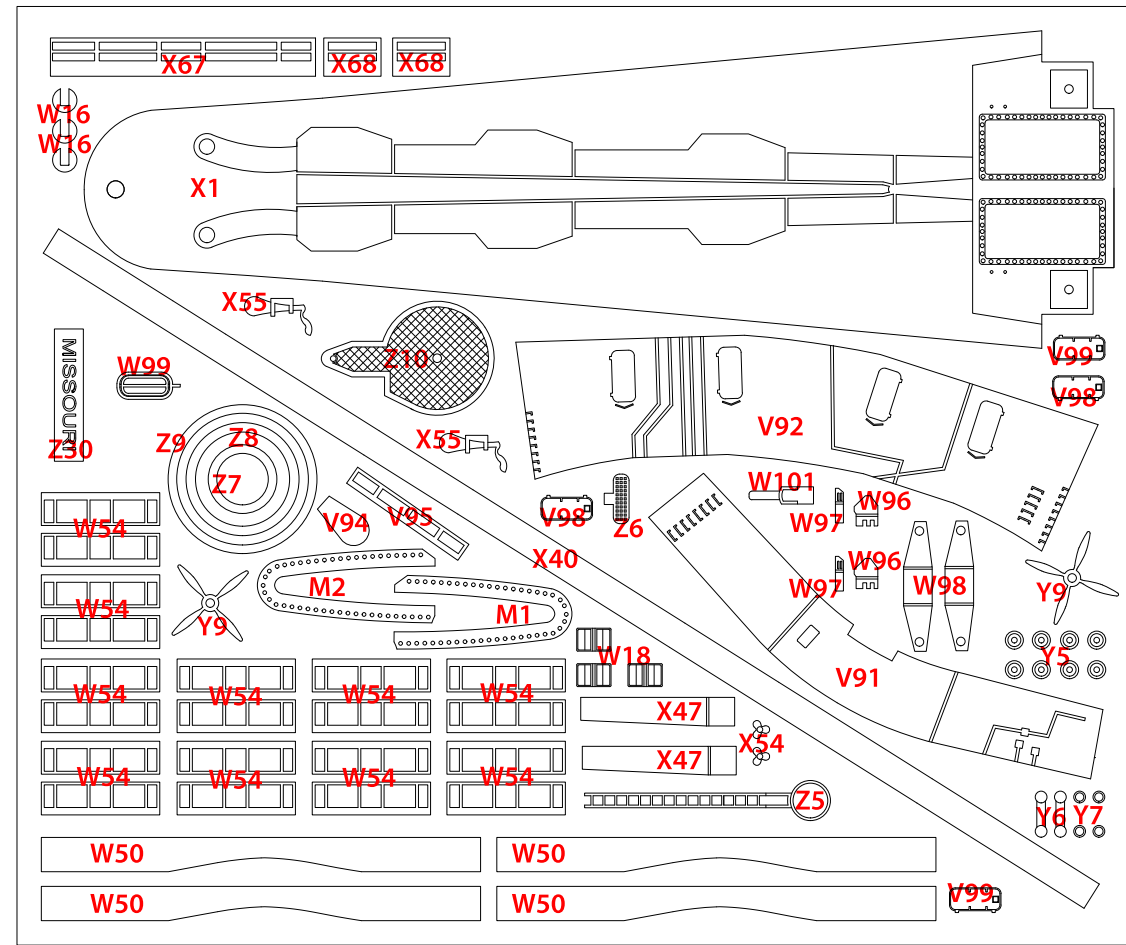

16002-32

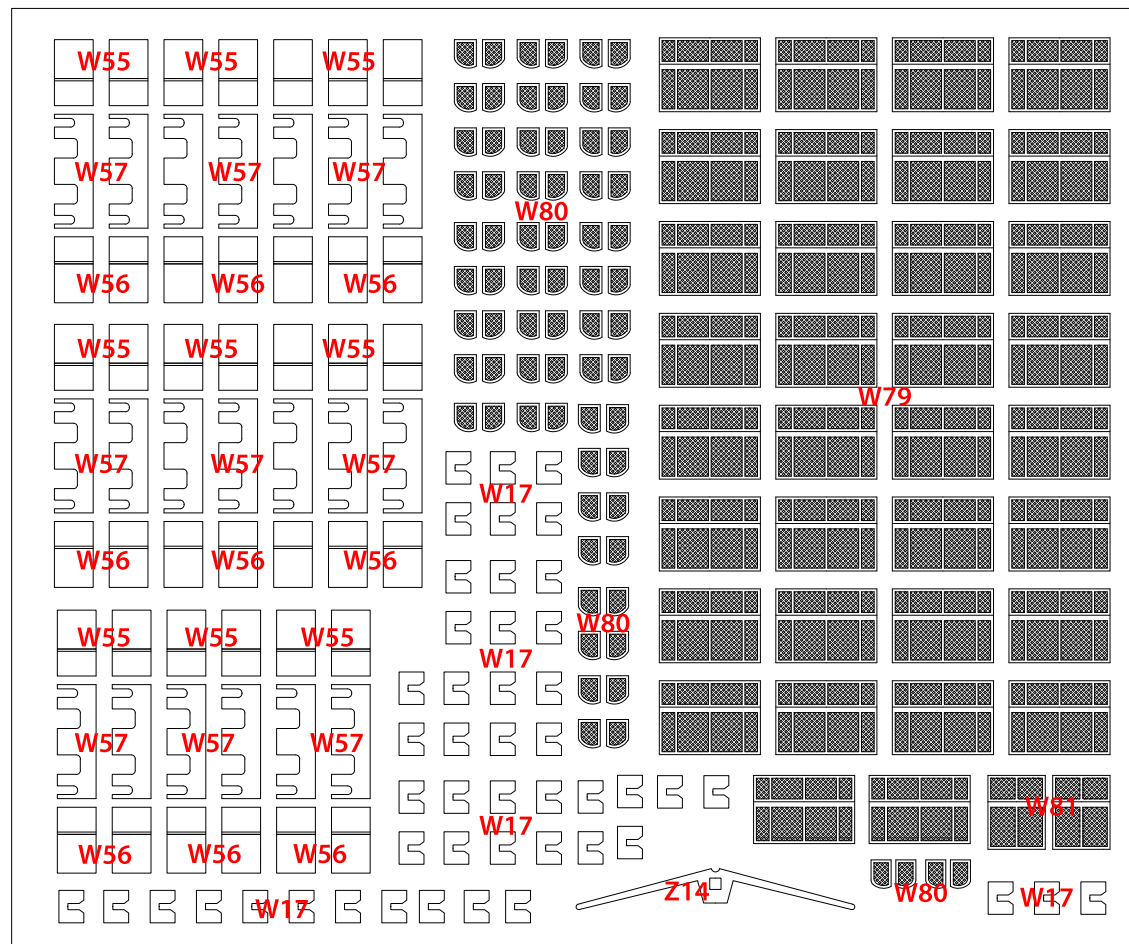

16002-31

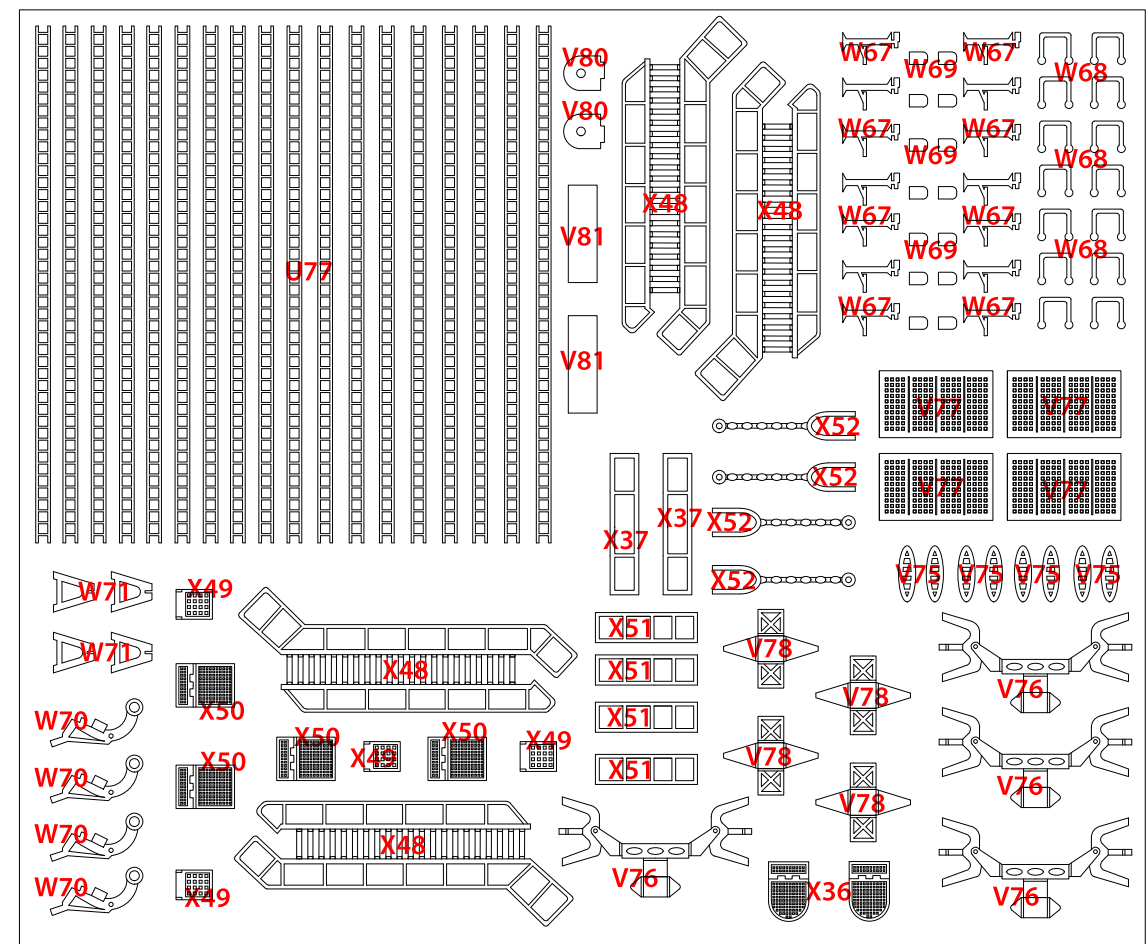

16002-33